

INTERNATIONAL
BIOLOGY
OLYMPIAD e. V.

IBO



All IBO examination questions are published under the following Creative Commons license:



CC BY-NC-SA (Attribution-NonCommercial-ShareAlike) -
<https://creativecommons.org/licenses/by-nc-sa/4.0/>

The exam papers can be used freely for educational purposes as long as IBO is credited and new creations are licensed under identical terms. No commercial use is allowed.

THEORETICAL EXAM 2

This exam lasts three hours

- Q 1-11 Animal biology
- Q 12-14 Biosystematics
- Q 15-23 Cell biology
- Q 24-29 Ecology
- Q 30-31 Ethology
- Q 32-41 Genetics & Evolutionary biology
- Q 42-49 Plant biology

Each correctly answered question gives you 1 point, i.e. all four statements are correct.

If only three statements in a question are correct, you get 0.6 points

If only two statements in a question are correct you get 0.2

If only one statement in a question is correct you get 0.0

If no statements in a question is correct, you do not get any points.

Q. 1

Conus snails produce potent conotoxins (peptides), which are used in defense and paralysis of prey. Conotoxins affect the neuromuscular end plates. Four toxins, A-D, have the following effects:

- A prevents the inactivation of Na^+ channels in the presynaptic axon
- B blocks K^+ channels in the presynaptic axon
- C blocks Ca^{2+} channels in the presynaptic end plate
- D blocks acetylcholine receptors

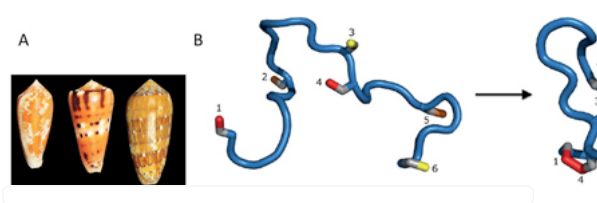

A, *Conus* snails; B, model of an unfolded *Conus* toxin (left) (1-6 are cysteine side chains) and, to the right, one possible 3-D folding through disulphide binding between pairs (e.g. 2 and 5) of cysteine (from Safavi-Hermami et al. 2014).

Indicate if each of the following statements is true or false.

Toxin D inactivates the skeletal muscles

Toxins A and B will cause muscle twitching when injected in the prey

Toxin C interferes with the exocytosis of neurotransmitters

The peptide in Fig. B may be folded in various ways, but all folded molecules have the same effect, if the primary structure of the peptides remains unchanged

TRUE FALSE

Solution:

1. **True**

Toxin D deactivates both the skeletal muscles and the transmission in the autonomous nervous system

D blocks acetylcholine receptors

Acetylcholine is a chemical neurotransmitter, that binds to and activates a membrane receptor, and consequently, toxin D deactivates muscles and the nervous transmission, because it blocks acetylcholine receptors.

2. **True**

A prevents, that Na^+ channels in the presynaptic axon are inactivated

B blocks K^+ channels in the presynaptic axon

Toxin A leads to overstimulation of the muscle as the Na^+ channels do not close (they stay active). Depolarisation continues, and repolarization, caused by efflux of K^+ is impossible, because of toxin B's blocking of the K^+ channels, which ultimately results in tetanic muscle contractions.

(Na/K-pump transports Na out of cells and K into cells, but K also diffuses out and Na in. Ca causes contraction of muscles.)

Paralysis is loss of muscle function.

3. **True**

C blocks Ca^{2+} channels in the presynaptic end plate

The Ca^{2+} channels in the presynaptic end plate are channels, that allow Ca^{2+} to diffuse into the terminal. The resulting rise in Ca^{2+} concentration in the terminal causes some of the synaptic vesicles to fuse with the terminal membrane, releasing the neurotransmitter.

Toxin C locks these channels, and consequently reduces the release of neurotransmitter into the synaptic cleft, i.e. it switches off the pain signal pathways in the spine, e.g. as seen in the commercial medicine Prialat (**Primary Alternative** to morphine).

4. **False**

Different tertiary structures will give different forms and distribution of charges, and as the peptide should match the receptors' form and distribution of charges, the statement is very unlikely. The binding between cysteins is between sulphur, and in Fig. B, six cysteins can produce 15 kinds of bridges ($=6 \times 5/2$) and only one is biologically active. Cystine is the amino acid result of this binding (Knowledge).

Reference

Safavi-Hermami, H., Andersen, K. M. & Ellgard, L. 2014. Giftsnegle som medicinskabe. *Aktuel Naturvidenskab* 2. (In Danish).

Olivera, B. M. 1997. *Conus* venom peptides, receptor and ion channel targets, and drug design: 50 million years of neuropharmacology. *Molecular Biology of the Cell* 8: 2101-2109.

Campbell et al. 2015. 10th ed. P. 1140.

Q. 2

Fish vary in the way they take up oxygen. The precise uptake is reflected in their hemoglobin dissociation curve, and its shape is determined both by phylogeny and the habitat of the fish (Fig.).

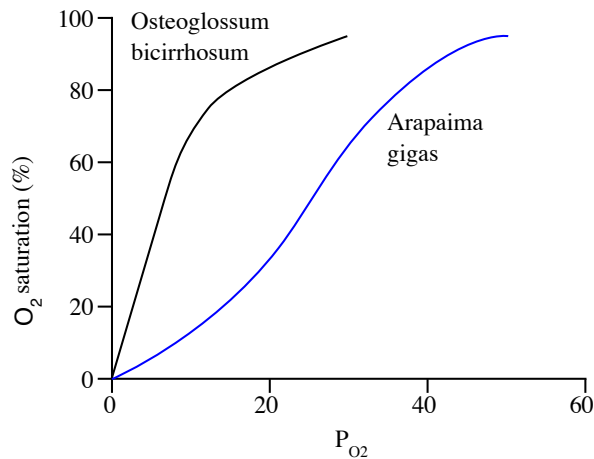

Hemoglobin dissociation curves for two species of fish *Osteoglossum bicirrhosum* and *Arapaima gigas*.

Indicate if each of the following statements is true or false.

O. bicirrhosum lives in faster-running water than *A. gigas*

TRUE FALSE

O. bicirrhosum has a lower metabolic rate than *A. gigas*

O. bicirrhosum is an air breather (going to the surface), whereas *A. gigas* is a gill-breather

O. bicirrhosum lives at the surface, whereas *A. gigas* is a deep water species

Solution:

1. **False**

Fast running water is richer in oxygen, thus a lower affinity of oxygen uptake is needed. Consequently, it is likely that Fish A is living in slow running water.

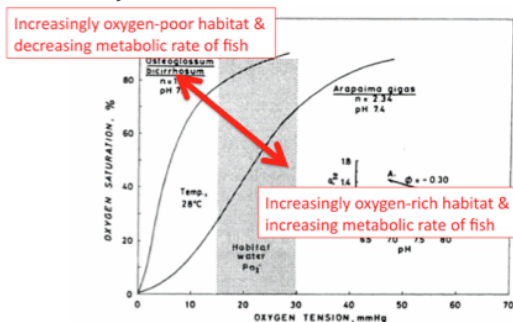

2. **True**

Fish A does not release its oxygen before P_{O_2} is very low, and that is not a problem if A has a low metabolic rate.

3. **False**

An air breather is less dependent upon the hemoglobin-oxygen affinity relationship, thus its hemoglobin has, in general, a lower affinity for oxygen, i.e. Fish A must be a gill-breather.

4. **False**

At the surface, oxygen conditions are more favourable than at deeper water. Thus one would expect fish A to live in the depth, because its curve shows a much higher O_2 affinity at lower P_{O_2} .

Q. 3

Lung ventilation (or minute ventilation, V) at increasing workload (oxygen uptake) was measured for two men. Person 1 (black) was untrained, and his V was measured before and after a few weeks of training. His body weight before and after intensive training was 70 kg and 75 kg, respectively. Person 2 (red) weighed 70 kg and was well trained. His V as a function of work was measured only once (Fig.).

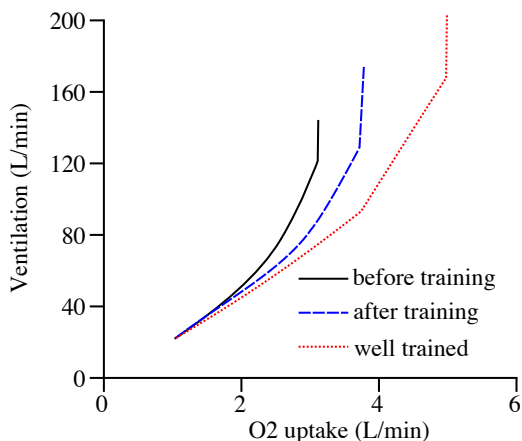

Lung ventilation V (atmospheric air L/min) as a function of total maximum oxygen uptake (L/min) for person 1 before training (black) and after training (blue dashed), and for person 2 (red dotted).

Indicate if each of the following statements is true or false.

TRUE FALSE

After training, person 1 has improved his VO₂max (i.e. max. oxygen uptake/L/min/kg body weight) about 30% (±5%)

 TRUE FALSE

Training by person 1 affected both start and extent of hyperventilation

 TRUE FALSE

Further training is expected to increase person 1's anaerobic endurance significantly

 TRUE FALSE

A very high V is mainly achieved by an increase in breathing frequency and not depth of breathing

 TRUE FALSE

Solution:

1. False

The idea of this question is to test the students' ability to explain changes in lung ventilation and oxygen uptake as a function of training.

Before training ca. $3.0 \text{ L O}_2 \times 70 \text{ kg}^{-1} \times \text{min}^{-1} = 42.9 \text{ ml O}_2 \text{ kg}^{-1} \times \text{min}^{-1}$
 After training ca. $3700 \text{ mL O}_2 \times 75 \text{ kg}^{-1} \times \text{min}^{-1} = 49.3 \text{ ml O}_2 \text{ kg}^{-1} \times \text{min}^{-1}$
 Improvement is only $(49.3 - 42.9) \times 100 / 42.9 = 14\%$.

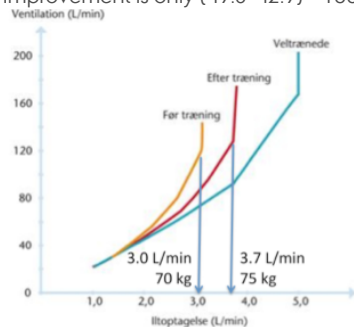

2. True

Hyperventilation is uncontrolled, rapid breathing.

The vertical part of the curves is the hyperventilation part. The lower endpoint of the hyperventilation line moves from about VO₂max = 3.0 to 3.5 after training, and the extent of hyperventilation is also affected, because the length of the vertical hyperventilation line is increased after training.

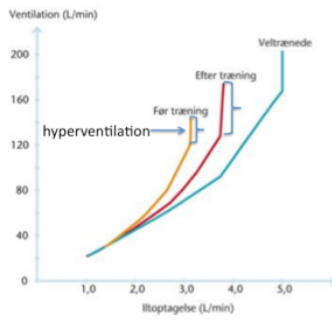
3. **False**

This is unlikely, since the hyperventilation lines of the two curves (Person 1 after training and Person 2) are of a somewhat similar length (see arrows). What is going to change will be an increase in the VO_{2max} at which anaerobic work is initiated.

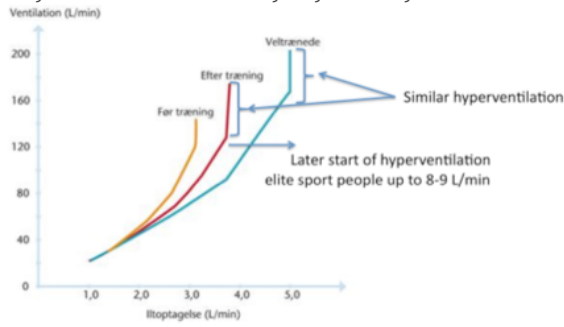
4. **True**

An increase can be driven by both an increase in depth breathing ($\leq 50\%$ of vital capacity) and frequency, but at very high workloads only frequency increases.

Q. 4

Morbid obesity can be treated surgically by a gastric bypass, where a part of the stomach and the proximal part of the intestine are bypassed. A group of obese individuals were enrolled in a study, in which their glucose and hormone levels were measured after an ingestion of glucose before and after gastric bypass surgery (Fig.).

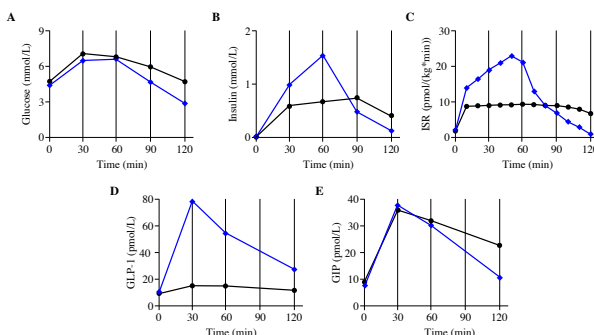

Effects of a glucose ingestion at time = 0 on the level of various parameters. Black circles indicate levels before gastric bypass, and blue diamonds indicate levels 3 months after gastric bypass. A, glucose level; Fig. B–C, insulin concentration and its secretion rate (ISR); Fig. D, Glucagon-Like Peptide 1 (GLP-1, gut hormone); and Fig. E, Gastric Inhibitory Polypeptide (GIP, gut hormone) (from Jørgensen et al. 2013).

Indicate if each of the following statements is true or false.

TRUE FALSE

Gastric bypass leads to a stronger and shorter insulin response to an increased glucose level

TRUE FALSE

From the study, GIP is expected to induce insulin secretion

TRUE FALSE

Change in GLP-1-level after gastric bypass surgery may explain the faster increase in ISR

TRUE FALSE

Blocking the effect of GLP-1 might be an efficient way to treat diabetes

TRUE FALSE

Solution:

1. True

The idea of the question is to test the students' ability to combine the different curves and suggest cause-effect relationships.

After the bypass surgery, the insulin response is stronger, peaks earlier and is shorter and glucose level drops to almost half compared to the before-bypass situation (Figs. A-C).

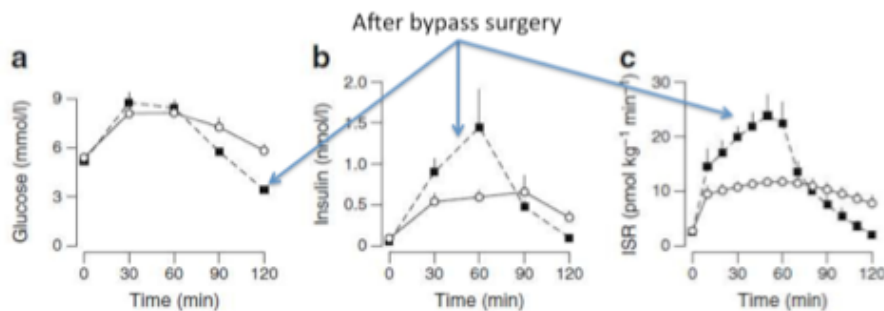

2. False

This is the general Wikipedia-belief, but Figs. C and E do not suggest a strong causal relationship from GIP to insulin, because GIP level does not show an effect until 60 min, and an insulin effect is seen earlier, and ISR has already increased within the first 30 min (Figs. C and E).

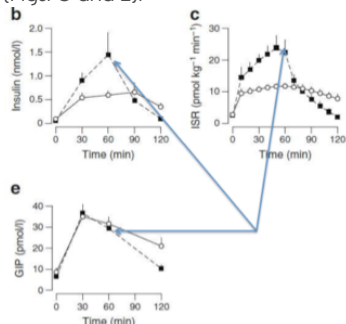

3. True

GLP-1 shows a large increase and this happens within the first 30 min, thus the time-relationship with ISR seems more plausible than for GIP (Figs. B-D).

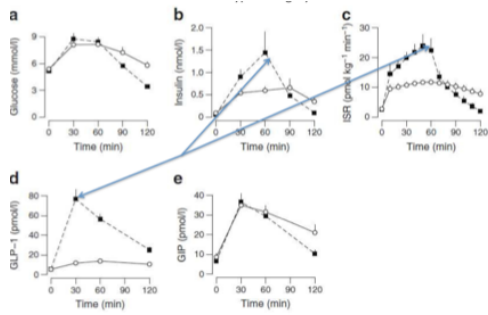

4. False

Blocking the effects of GLP-1 would lead to a lower insulin secretion (in the pre-surgery test, low GLP-1 and low insulin secretion co-occur). This would not be beneficial in the treatment of diabetes, as diabetics lack insulin or show increased insulin resistance. GLP-1 analogues are widely used in the treatment of diabetes (Figs C and D).

Reference

Jacobsen, S. H. et al. 2014. Effects of gastric bypass surgery on glucose absorption and metabolism during a mixed meal in glucose-tolerant individuals. *Diabetologia* 56: 2250-2254.

Jørgensen, N. B. et al. 2013. Exaggerated Glucagon-like Peptide 1 response is important for improved beta-cell function and glucose tolerance after Roux-en-Y gastric bypass in patients with type 2 Diabetes. *Diabetes* 62: 3044-3052.

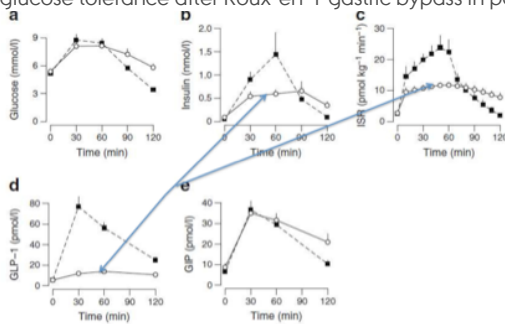

Q. 5

Partial atmospheric oxygen pressure P_{O_2} and ambient temperature decrease with increased elevation above sea level. This affects the respiratory physiology and species richness of many animal groups, e.g. hummingbirds (Fig.). An important physiological feature of hummingbirds is their ability to enter torpor, a state of reduced physiological activity, to save energy.

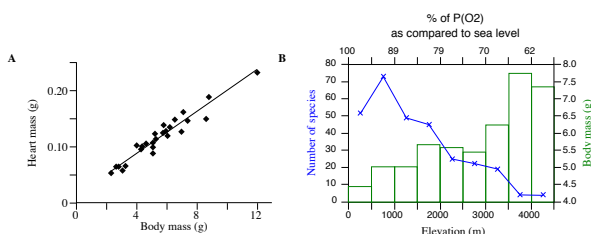

A, relationship between heart mass and body mass of hummingbird species; B, average body mass (grams) per 500 m altitudinal zone (histogram, right Y-axis) and number of species of hummingbirds (x-x-line, left Y-axis) at different elevations (lower X-axis). The percentage of partial oxygen pressure compared to sea level is also given (from Altshuler & Dudley 2002).

Indicate if each of the following statements is true or false.

	TRUE	FALSE
Daily decreased physiological activity is common in montane hummingbirds	<input type="radio"/>	<input type="radio"/>
Above 500 m, diversity of hummingbirds is negatively correlated with height above sea level	<input type="radio"/>	<input type="radio"/>
The heart mass is negatively correlated to the partial pressure of oxygen	<input type="radio"/>	<input type="radio"/>
Hummingbird wing load (body mass/wing area) declines with altitude	<input type="radio"/>	<input type="radio"/>

Solution:

1. True

The idea of the question is to test the students' ability to make some logical deductions about how hummingbirds are able to survive at high altitudes, partly based on an interpretation of the figures.

One pronounced physiological feature of hummingbirds that probably evolved in parallel with the occupation of higher elevations is torpor. Daily torpor is pronounced in montane hummingbirds. This is a way of saving energy. The conditions in the mountains are reduced air density and colder temperature, increasing the energy demands, and low oxygen level hampers metabolic rate (Knowledge).

2. True

There are 50 species at sea level, increasing to 70 species at 750 m above sea level; then dropping linearly to a few species at higher altitudes.

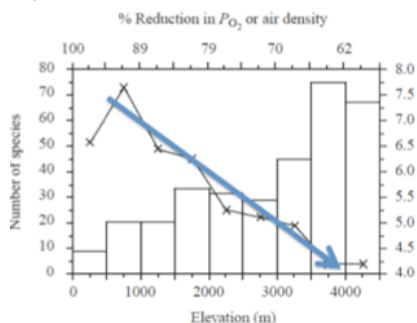

3. True

Larger body mass means larger heart mass (Fig. A), which means larger cardiac output (more blood through the circulatory system per time), which means more oxygen uptake.

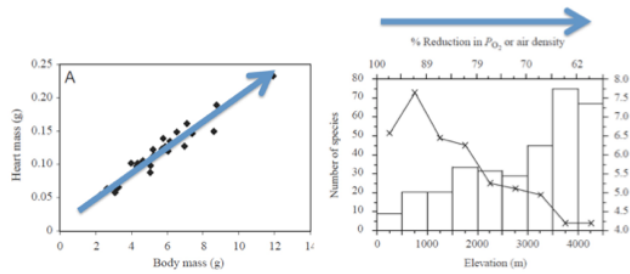

Larger body mass \rightarrow larger heart mass \rightarrow larger cardiac output (more blood through the circulatory system per time) \rightarrow more oxygen uptake.

4. True

Probably due to the selection pressure from a reduction in oxygen with altitude, wing area has to increase (corrected for body mass) (answered without figure).

Reference

Altshuler, D. L. & Dudley, R. 2002. The ecological and evolutionary interface of hummingbird flight physiology. *Journal of Experimental Biology* 205: 2325–2336.
Campbell et al. 2015. 10th ed. P. 952 (torpor).

Q. 6

An important function of an electrocardiogram (ECG) is to give information about the general health of a person. The ECG of two students was compared (Fig. C).

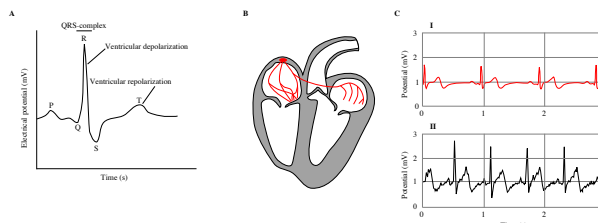

A, schematic representation of a standardized ECG; B, a snapshot of a heart with activated innervations in red, pictured as if facing the student; C, electrocardiograms of two young male students (I and II) measured over 3 seconds.

Indicate if each of the following statements is true or false.

- | | TRUE | FALSE |
|---|-----------------------|-----------------------|
| Blood flows from the right ventricle to the lungs, to the left atrium, to the left ventricle, to the body, and back to the right atrium | <input type="radio"/> | <input type="radio"/> |
| Students I has a heart rate of 80 beats/minute | <input type="radio"/> | <input type="radio"/> |
| If the stroke volume of student 1 is 70 mL/beat, then his cardiac output will be about 4.4 L/minute | <input type="radio"/> | <input type="radio"/> |
| The heart in fig. B is at the R peak | <input type="radio"/> | <input type="radio"/> |

Solution:

- True**
(Knowledge)
- False**
(1) The 3 beats for student I covers 2.9 seconds → heart rate of $60 \text{ seconds} \times 3 \text{ beats} / 2.9 \text{ seconds} = 63 \text{ beats/minute}$ (Fig. C). Thus student 1 does not have a heart rate of 80 beats/minute.
(2) The 5 beats for student II covers 3.0 seconds → heart rate of $60 \text{ seconds} \times 5 \text{ beats} / 3 \text{ seconds} = 100 \text{ beats/minute}$.

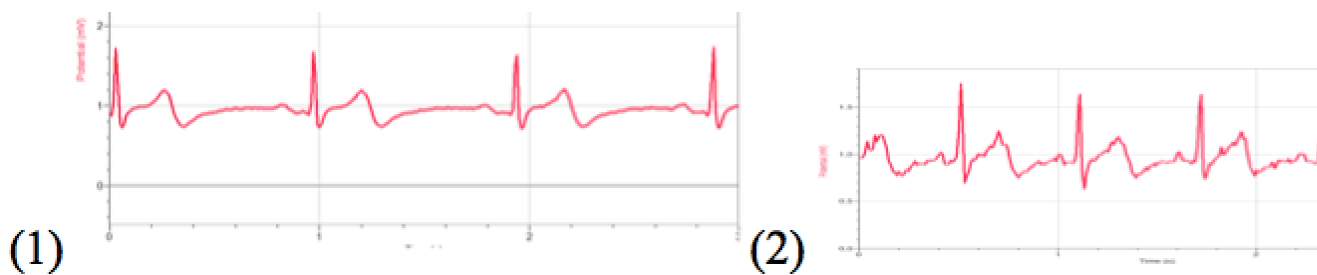

- True**
Cardiac output = stroke volume x heart rate →
 $4.4 \text{ L/min} = 70 \text{ mL/beat} \times 63 \text{ beats/min}$ (the latter is read from the figure, and related to Statement 2).
- False**
In Fig. B, the heart is at the beginning of a normal ECG wave, i.e. at peak P. Both atria contract in unison (Knowledge).

Reference

Campbell et al. 2015. 10th ed. P. 1006-1008.

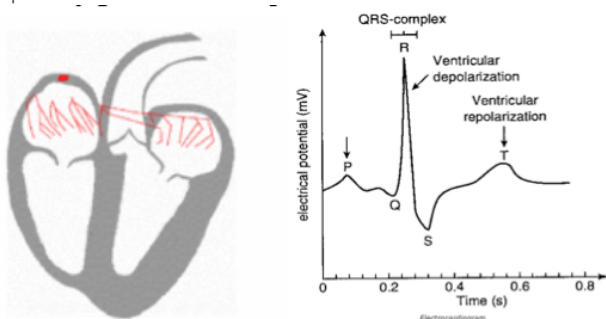

Q. 7

Variation in testosterone levels has major effects on general male physiology. Concentration of testosterone was measured in blood plasma from five groups of men (Fig.).

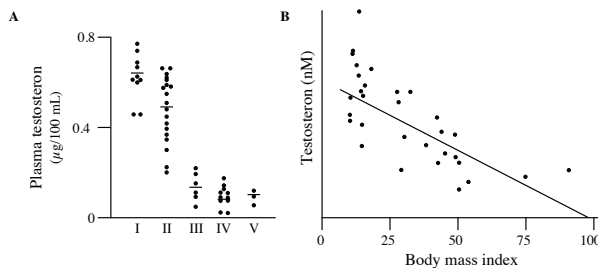

A, plasma level of testosterone in: I, Males 16-43 years old; II, Males 44-92 years; III, Males with underdeveloped pituitary glands; IV, Males with removed testes; and V, Males after treatment with injections of estrogen for some time. Each dot represents an individual, and the horizontal bars are group averages; B, plasma testosterone level in men as a function of body mass index ($T = 23.94 - 0.26 \text{ BMI}$) (from Zumoff et al. 1990).

Indicate if each of the following statements is true or false.

Males-IV have reduced testosterone level due to negative feed-back regulation

TRUE FALSE

Males-IV have a high LH concentration compared to Males-I

Estrogen injections in males lead to very low concentrations of LH

Even mild obesity (25<BMI < 30) might be much more important to testosterone level than higher age (> 43 years)

Solution:

1. **False**

Males IV have underdeveloped pituitary glands. The low concentration of testosterone is caused by reduced levels of LH (luteinizing hormone), because of their underdeveloped pituitary (Knowledge)

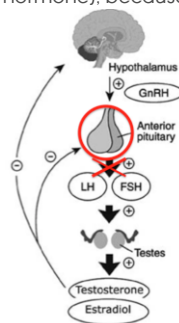

2. **True**

Males-V have removed testes. Thus they do not produce any testosterone, which means no negative feedback to the anterior pituitary, which then continues to produce LH.

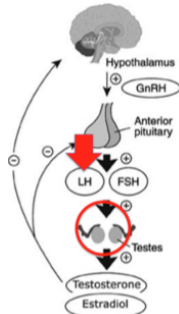

3. **True**

Males-VI after treatment with injections of estrogen. Estrogen has like testosterone a negative-feed back regulation effect on the pituitary gland. Thus extra estradiol causes a reduced LH release (Males-VI).

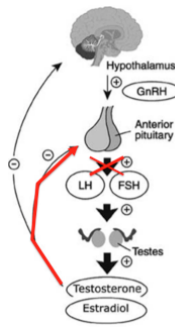

4. False

Testosterone level is on average reduced from c. 0.65 to c. 0.50 from Males-I to Males-II (Fig. A), i.e. a reduction of about $(0.15 \cdot 100 / 0.65 =) 23\%$. A reduction of the testosterone level of 23% happens, when BMI increases from 20 to 37 (BMI = body mass (kg)/height² (m)); using the equation in the legend to Fig. B: $T = 23.94 - 0.26 \text{ BMI}$; 37 is really severe obesity, for example a 180 cm tall man with a body mass of 97 kg has a BMI of 30, one with a BMI = 37 weighs 120 kg (Fig. B). The cause might be a higher production of estrogen in obese men, which reduces the production of testosterone. Weak obesity would be below 30 and this is less important than age with respect to reduction in testosterone production.

Reference

Zumoff, B. et al. 1990. Plasma free and non-sex-hormone-binding-globulin-bound testosterone are decreased in obese men in proportion to their degree of obesity. *Journal of Endocrinology & Metabolism* 71: 929-931.
 Campbell et al. 2015. 10th ed. P. 1067.

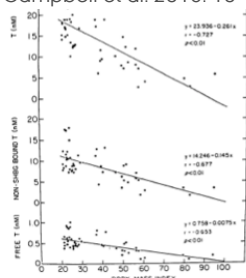
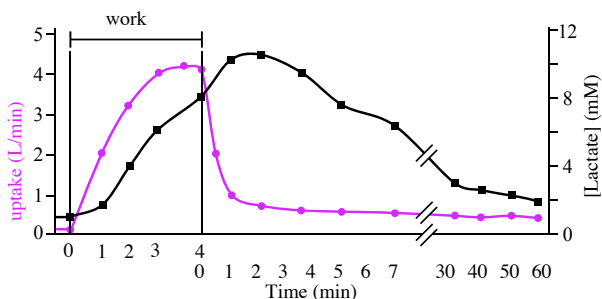

FIG. 2. Total, non-SHBG bound, and free plasma T were very highly negatively correlated with BMI: for total T, $r = -0.827$, $P < 0.01$; for non-SHBG-bound T, $r = -0.877$, $P < 0.01$; and for free T, $r = -0.933$, $P < 0.01$.

Q. 8

Oxygen uptake and lactate concentration in the blood were measured in a 70 kg male person before, during and after he had exercised (worked) for 4 minutes. The intensity of the exercise (work) corresponded to the consumption of 5 L oxygen/min.



Changes in oxygen uptake (purple, left Y-axis, L/min) and lactate concentration (black, right Y-axis, mM lactate in blood) before, during and after an exercise or work period of 4 min.

Indicate if each of the following statements is true or false.

The person cannot work for 4 min at intensities equal to 5 L O₂-uptake/min, as his maximum aerobic work capacity is 4.2 L/min

The person has an aerobic capacity of 60 ml O₂/(kg min)

When blood lactate exceeds 11 mM, excretion begins through the kidneys, which is why its concentration declines

Excess O₂-uptake after the end of work is partly due to metabolism of lactate and not to gluconeogenesis

TRUE FALSE

Solution:

1. **False**

The idea of this question is to test the students' ability to make deductions from the figure and combine it with their knowledge about respiration and lactate fermentation (aerobic/anaerobic work).

He can work anaerobic as well. The 4.2 L/min can be read from the figure.

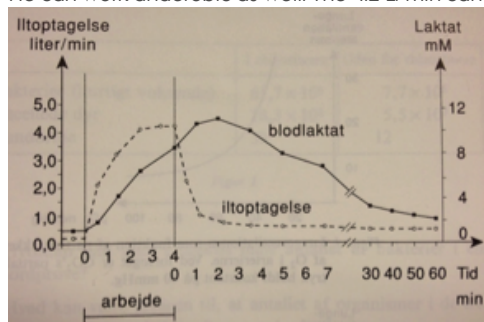

2. **True**

4.2 L oxygen/min = 4200 ml oxygen/min ÷ 70 kg = 60 ml oxygen/(kg min).

3. **False**

The threshold of blood lactate is 11 mM/L (Fig.), but gluconeogenesis and lactate metabolism take place in the liver and this is causing the decline (Knowledge).

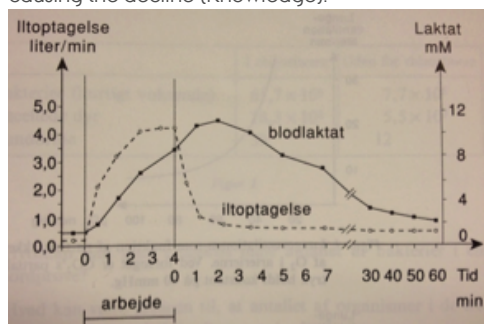

4. **True**

It takes an hour to reconstitute, which proves that the four minutes of work exceeded his aerobic capacity. Excess lactate is slowly

carried away by the blood to the liver, where it is converted back to pyruvate by liver cells, further converted to acetylCoA and then it enters the citric acid cycle.

Reference

Crone, C. et al. 1990. *Physiology*.

Campbell et al. 2015. 10th ed. Pp. 244ff.

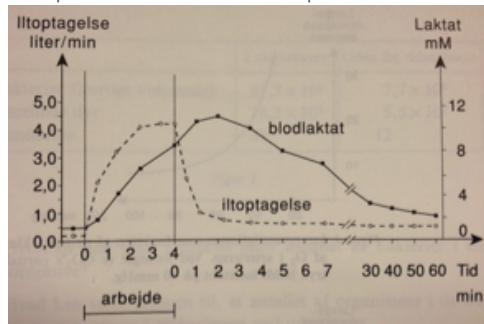

Q. 9

Camels are well adapted to desert life. Their hump consists mainly of fat, especially tripalmitin ($C_{51}H_{98}O_6$). A dehydrated camel's body temperature may vary from 34.5°C at night to 40.5°C during day.

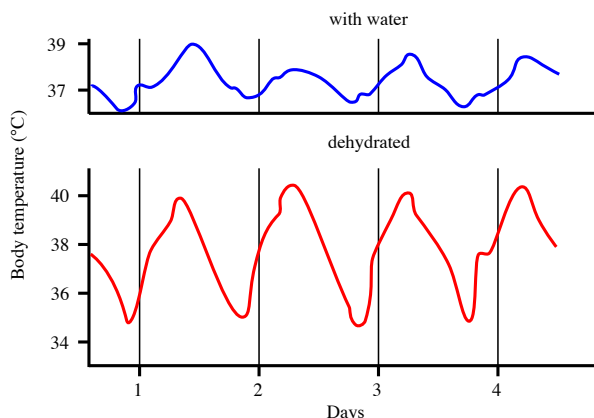

Body temperature of a dehydrated (red) camel compared to one well supplied with water (blue) (from Schmidt-Nielsen et al. 1957).

Indicate if each of the following statements is true or false.

TRUE FALSE

The respiration of 1 kg tripalmitin will provide the camel with more than 1 liter of water (molar mass for C = 12, H = 1, O = 16)

 TRUE FALSE

The respiratory quotient of tripalmitin (CO_2 eliminated/ O_2 consumed) is 1.4

 TRUE FALSE

During the day, a 500 kg dehydrated camel accumulates 2000 kcal of heat in its body (about 0.9 cal is required to increase one gram of tissue 1°C)

 TRUE FALSE

To keep a constant body temperature, a camel would need 2500 ml of water to get rid of 1000 kcal (1 ml water needs 580 cal to evaporate)

 TRUE FALSE

Solution:

1. **True**

The idea of this question is to test students' ability to calculate various parameters related to water economy.

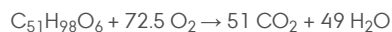

1 mol tripalmitin gives 49 mol water

Molar mass for tripalmitin is $51 \times 12 + 98 \times 1 + 16 \times 6 = 806 \text{ g/mol}$

1 kg tripalmitin = $1000 \text{ g} / 806 \text{ g/mol tripalmitin} = 1.24 \text{ mol}$

$1.24 \text{ mol tripalmitin} \sim 1.24 \times 49 = 60.79 \text{ mol water} \rightarrow 60.79 \text{ mol} \times 18 \text{ g water (molar mass of water)}/\text{mol} = 1094 \text{ g water} = 1.094 \text{ L water}$.

However, this is theory! The evaporation from especially lungs during the burning of tripalmitin means a loss of much water.

2. **False**

The respiratory quotient (RQ) is $51 \text{ mol CO}_2 \text{ eliminated from body} / 72.5 \text{ mol O}_2 \text{ consumed} = 0.7$ (tripalmitin) (Knowledge).

3. **False**

A camel's body temperature may vary between 34.5°C at night to 40.5°C during the day (Fig.). A 500 kg camel that increases its body temperature 6°C (from 34.5° to 40.5°) stores: $500,000 \text{ g} \times 6 \text{ degrees} \times 0.9 \text{ cal.} = 2,700,000 \text{ cal} = 2,700 \text{ kcal}$.

4. **False**

$1000 \text{ kcal may evaporate } 1000,000 \text{ cal} / (580 \text{ cal/ml water}) \text{ of water} = 1724 \text{ ml water}$

Reference

Schmidt-Nielsen, K. 1959. The physiology of the camel. *Scientific American* 201: 140-151.

Q. 10

Deer mice have a wide geographic range, e.g. with respect to altitude. This is partly explained by their respiratory physiology (Fig.).

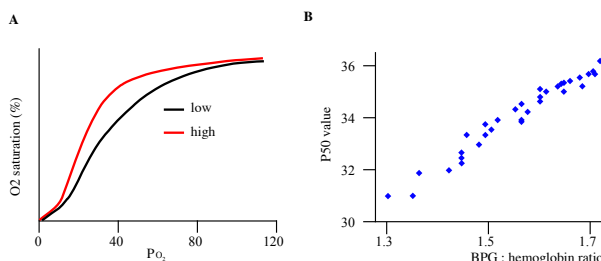

A, oxygen saturation (%) of blood of deer mice from low and high altitude habitats as a function of the partial pressure of atmospheric oxygen PO₂; B, P₅₀ is the partial PO₂ at which the blood is 50% O₂-saturated, here plotted against the BPG (2,3-bisphosphoglycerate) : hemoglobin ratio. BPG affects the oxygen affinity of hemoglobin (from Tufts et al. 2013).

Indicate if each of the following statements is true or false.

Hemoglobin in high-altitude deer mice does not release oxygen as easily as compared to that low-altitude mice

High-altitude mice have lower P₅₀ than low-altitude mice

If BPG concentration in blood increases, the saturation curve in Fig. A will shift to the right

Assuming that adaptation to altitude is genetically determined, P₅₀ values will most likely remain the same if a mouse is transferred to another altitude

Solution:

1. True

The idea of the question is to test the students' ability to deduce how altitude affects oxygen uptake and release in animals.

The saturation curve (Fig. A) for high-altitude adapted mice is to the left of the one for the low altitude-adapted mice. The hemoglobin has a high affinity for oxygen, but releases it at a lower PO₂ than hemoglobin at lower altitudes.

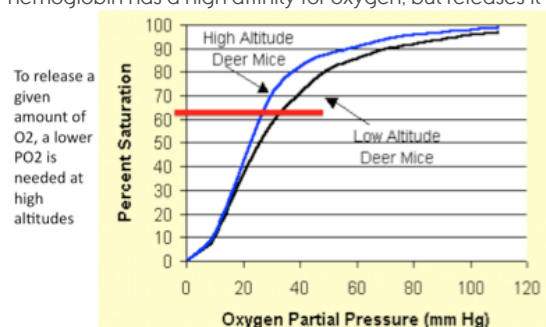

2. True

Fig. A shows that high altitude mice have a 50% saturation at an PO_{2, 50%} ≈ 22 mm Hg, while low altitude mice have 50% saturation at a somewhat higher PO_{2, 50%} ≈ 24 mm Hg.

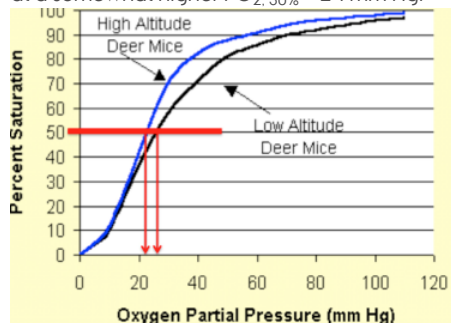

3. True

The higher the DPG : hemoglobin ratio, the higher the PO_{2, 50%} value (Fig. B) and this leads to a shift to the right in Fig. A as hemoglobin in low altitude mice more easily releases oxygen to the tissue, but it also becomes increasingly difficult at a given PO₂ to take up O₂ from lungs.

TRUE FALSE

Fig. B

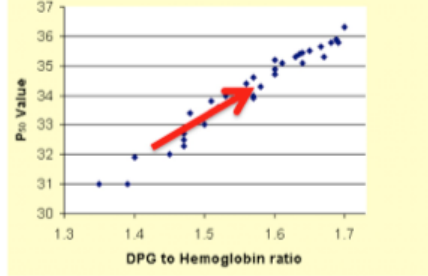
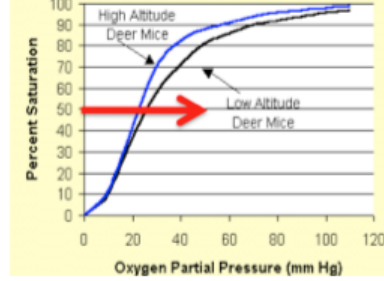

Fig. A



4. True

The assumption removes the possibility of physiological acclimatization, except if the trait shows phenotypic plasticity. In reality the study showed the reverse: high-altitude mice changed their PO_2 50% after six weeks in the lowland.

Reference

Tufts, D. M., Revsbech, I. G., Cheviron, Z. A., Weber, R. E., Fago, A. & Storz, J. F. 2013. Phenotypic plasticity in blood-oxygen transport in highland and lowland deer mice. *Journal of Experimental Biology* 216: 1167-1173.

Q. 11

The effect of consuming foods, which varied in their glycemic index (GI), on prolonged exercise were studied. GI expresses the effect of a particular type of food on a person's blood glucose level. At start of test, each person either got 1) Control, i.e. water (black squares); 2) LGI, i.e. a low GI meal + water (blue triangles), or 3) HGI, i.e. a high GI meal + water (red circles). Afterwards, each person rested, then cycled for 1 hr at 65% of her VO_{2max} , and finally at 90% VO_{2max} until exhaustion. Blood samples were taken before and during tests to measure levels of lactate, glucose and insulin (Fig.).

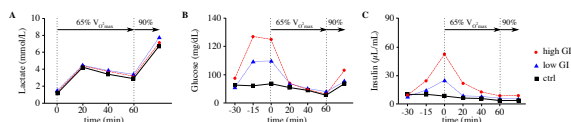

Levels of lactate A), glucose (B) and insulin in blood (C) before (pre-exercise) and during test. Each curve represents a treatment (red circles: high GI, blue triangles: low GI, black squares: control) (from Jamurtas et al. 2011).

Indicate if each of the following statements is true or false.

At the time of exhaustion, O_2 uptake was sufficient for complete metabolism

The level of lactate in the blood during exercise is influenced by the diet

Final test result at the time of exhaustion seems to be significantly affected by the kind of diet

The observed increase in blood glucose at the last phase of 90% VO_{2max} is due to an increase in fat metabolism and a reduced use of glucose

Solution:

1. **False**

The idea of this question is to deduce conclusions about metabolism from the figures from an experiment.

O_2 was not sufficient, evidenced in the high level of lactate (Fig. A) at the end of the test.

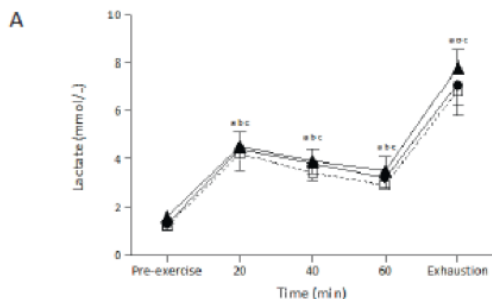

2. **False**

HGI must give the fastest increase in glucose, and the graph of filled circle symbols shows that.

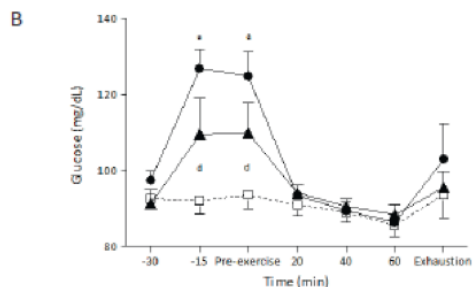

3. **False**

Effects are short-term. Levels of glucose and insulin are stable already after 20 min's of exercise, and lactate does not show any difference between the three treatments.

TRUE FALSE

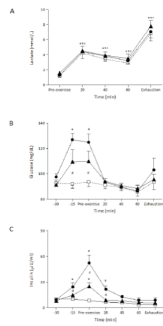

4. True

Although the exercise is taken place at 90% VO_{2max} the level of blood glucose increases, which could be due to a shift to fat metabolism (Knowledge). This is the explanation offered by Jamurtas et al. 2011.

Reference

Jamurtas, A. Z. et al. 2011. The effects of low and high glycemic index foods on exercise performance and beta-endorphin responses. *Journal of the International Society of Sports Nutrition* 8(15), 11 pp.

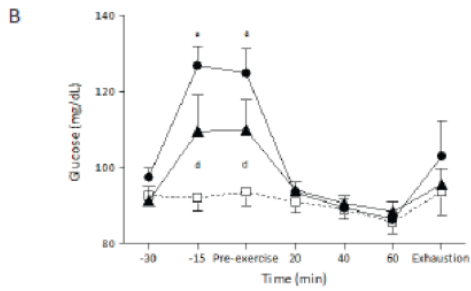

Q. 12

Horseshoe crabs are marine and only four extant species are known, while many have gone extinct. *Tachypleus gigas* (Tg), *T. tridentatus* (Tt) and *Carcinoscorpius rotundicauda* (Cr) are from southeast Asia, whereas *Limulus polyphemus* (Lp) lives on the east coast of N America. Tg and Cr overlap in their geographic range (from Andaman Sea (close to Thailand and Malaysia) to the South China Sea). Tt lives from Vietnam to Japan. Horseshoe crabs are "living fossils".

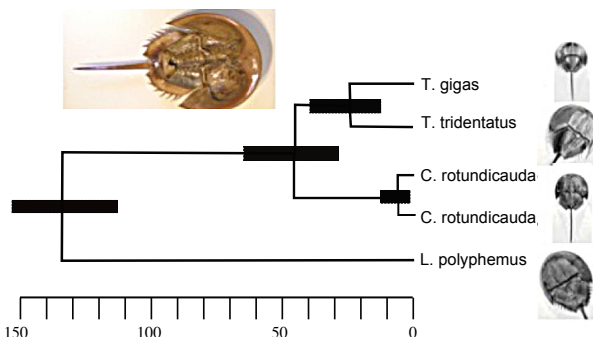

Phylogeny of extant horseshoe crabs. The unit of scale is a million years. Black bars indicate 95% confidence interval. The two populations of Cr are from Andaman Sea and Thailand (from Obst et al. 2012).

Indicate if each of the following statements is true or false.

TRUE FALSE

From the Fig., we can conclude that horseshoe crabs must be a slowly evolving group

TRUE FALSE

According to Fig., the Asian species constitute a monophyletic clade

TRUE FALSE

Speciation in horseshoe crabs seems to take between 5 and 45 million years

TRUE FALSE

The genera *Tachypleus* and *Limulus* are sister taxa

TRUE FALSE

Solution:

- False**
Horseshoe crabs = Limulidae

The idea of this question is to test students' ability to read a phylogeny and conclude about a phylogeographical case study.

This is impossible to know without information about all extinct species and, in the stem text it is said that there had been many more species.

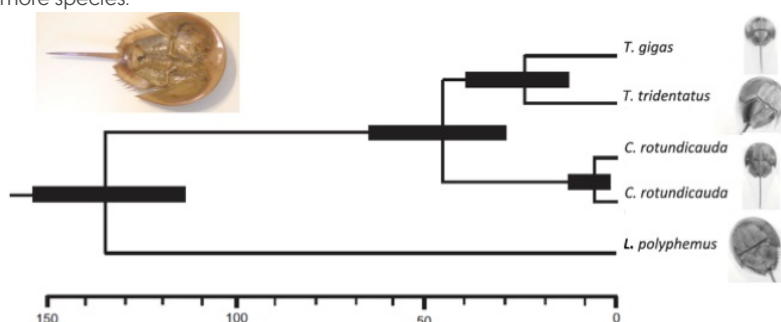

- True**
From the Figure, it is seen that it consists of the ancestor species and all its three descendents, so technically speaking it is a monophyly. However, we do not know how extinct species were nested within the group. That is why I write "According to Fig.".

- True**
In the Figure, it is seen that the two populations of *C. rotundicauda* separated about 7 million years ago (i.e. even after 7 million years they are still not separate species), and the two genera *Tachypleus* and *Carcinoscorpius* separated 45 million years ago. Thus without further knowledge about the rate of speciation one has to conclude that it takes 5-45 million years.

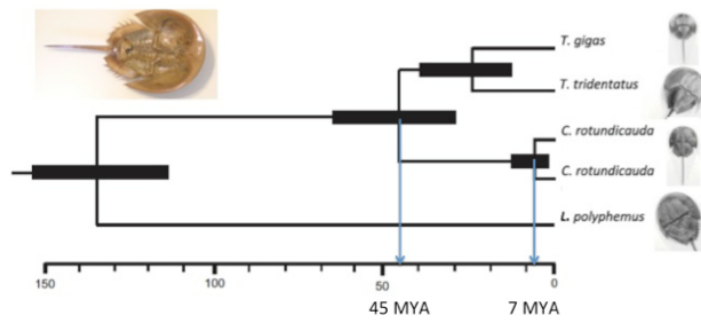
4. **False**

The genera Tachypleus and Limulus are sister taxa

They do not have an immediate common ancestor and hence are not each other's closest relative. *Carcinoscorpius* are nested within the two.

Reference

Obst, M., Faurby, S., Bussarawit, S. & Funch, P. 2012. Molecular phylogeny of extant horseshoe crabs (Xiphosura, Limulidae) indicates Paleogene diversification of Asian species. *Molecular Phylogenetics and Evolution* 62: 21-26.

Campbell et al. 2015. 10th ed. p. 764ff.

Q. 13

The flightless beetle genus *Tarphius* lives in humid forests and has 29 endemic species on the Canary Islands. The species are found on the five western islands of the archipelago, but not on the two eastern islands, closest to Africa. The more northern archipelago Madeira has additional species. A species may evolve on one island and then disperse to another island (ex situ-speciation) or it may evolve within an island from another *Tarphius* species already present there (in situ-speciation).

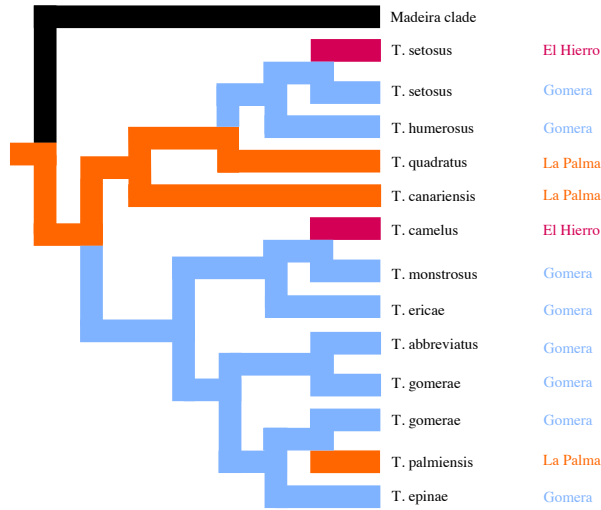

Part of the cladogram of *Tarphius* from the Canary Islands with the Madeira clade as an outgroup (black branch). Only species from three (La Palma, Gomera and El Hierro) of the five western islands are included (from Emerson & Oromí 2005).

Indicate if each of the following statements is true or false.

TRUE FALSE

The Canarian phylogeny suggests both ex situ-and in situ-speciation events

TRUE FALSE

From Madeira, *Tarphius* colonized the island of El Hierro

TRUE FALSE

All three islands were colonized twice

TRUE FALSE

Gomera is likely to be the Canarian Island with the highest habitat diversity of humid forest

TRUE FALSE

Solution:

1. True

The idea of this question is to test students' ability to draw phylogeographical conclusions.

This is seen from the figure. El Hierro has only ex-situ speciation, probably because it is the youngest island with the lowest habitat diversity.

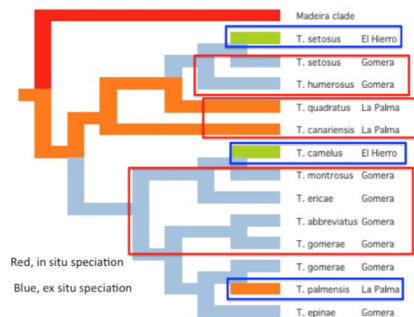

2. False

From the figure it is seen that the colonization from Madeira went to either Gomera or La Palma.

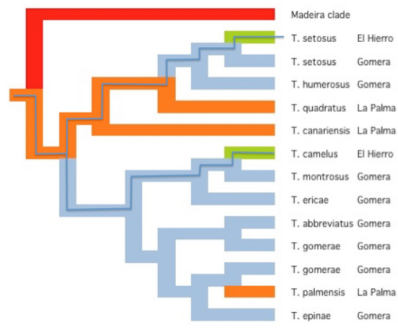

3. **True**

This is seen from the figure.

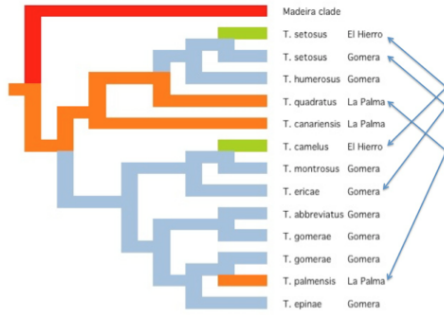

4. **True**

This would be a likely conclusion because Gomera has the highest number of species (and, in fact, Gomera does have the richest humid forests).

Reference

Emerson, B. C. & Oromí, P. 2005. Diversification of the forest beetle genus *Tarphius* on the Canary Islands, and the evolutionary origins of island endemics. *Evolution* 59: 586-598.

Q. 14

Figs and wasps have a long coevolutionary history. Figs depend on tiny wasps for pollination, which depend on fig inflorescences, because they lay eggs in the flowers and their larvae develop in the fruits. The breeding system of fig species may either be dioecy (with male and female trees) or monoecy (with hermaphroditic trees with male and female flowers). Wasps pollinate either actively, by carrying pollen in special body pockets or passively, without any specific pollen behaviour (Fig.).

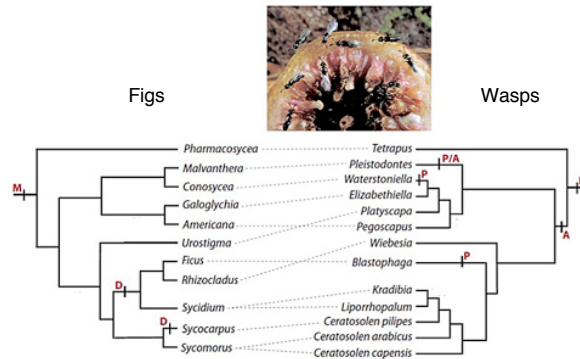

Phylogenies of some groups of figs (left) and wasps (right). Breeding system (M = monoecy, D = dioecy) and pollination mode of wasps (P = passive, A = active; P/A = dimorphic) are mapped onto the phylogenies. Transitions between breeding systems and between pollination modes are shown as small vertical bars on phylogenies. Dashed lines give the mutualistic relationships (from Herre et al. 2008).

Indicate if each of the following statements is true or false.

TRUE FALSE

Passive pollination mode is ancestral in the evolution of fig wasps

TRUE FALSE

Dioecy in figs is correlated to active pollination mode in wasps

TRUE FALSE

The coevolutionary match between figs and wasps is only seen at the level of genus and higher

TRUE FALSE

Pollination mode seems to be more labile evolutionarily than breeding system

TRUE FALSE

Solution:

1. **True**
2. **False**
3. **False**
4. **True**

Q. 15

Tuberculosis is caused by the bacterium *Mycobacterium tuberculosis*. One third of the world's population is currently infected with *M. tuberculosis*, and about 10% of these suffer from tuberculosis (TB). TB annually kills more than 1 million people. The pathogenic life cycle of *M. tuberculosis* is shown in Fig.

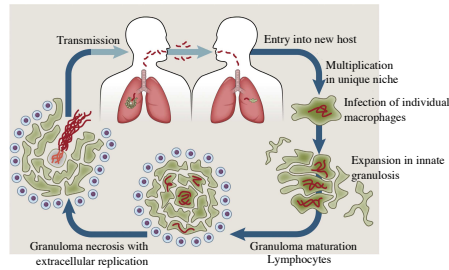

Pathogenic life cycle of *M. tuberculosis* (*Mt*). A granuloma is a group of tightly linked macrophages (from Cambier et al. 2014).

Indicate if each of the following statements is true or false.

TRUE FALSE

Transmission of tuberculosis requires physical contact

TRUE FALSE

Theoretically, a person with macrophage deficiency would be expected to suffer greatly from an *Mt* attack

TRUE FALSE

The granuloma of macrophages is the host's successful way of reducing the spread of the disease within the body

TRUE FALSE

A new generation of *Mt* is released when the macrophages in the granuloma die

TRUE FALSE

Solution:

1. **False**

Macrophages are described in some details in Reece et al. 10th ed. p. 181-812.

As shown in the figure transmission happens by air – a few bacteria enclosed in tiny droplets (aerosol particles).

2. **False**

Since macrophages are the vehicles of *M. tuberculosis*, one would expect the opposite.

3. **False**

From the figure, we see that it is the opposite; macrophages are under the control of *M. tuberculosis* and helps spreading the disease to new hosts.

4. **True**

A new generation of *Mt* is released when the macrophages in the granuloma die

This is seen in the figure in the left lower corner.

Q. 16

A gene (coding sequence) can be expressed by cloning it into an expression plasmid using restriction enzymes and DNA-ligase. A plasmid (A), a gene of interest (B), and the recognition sequences for four restriction enzymes (C) are shown in the figure. Different cloning strategies, expressed in the statements below, could be used to insert the "Coding sequence and Terminator" of this gene into the plasmid to produce a recombinant plasmid that expresses the gene.

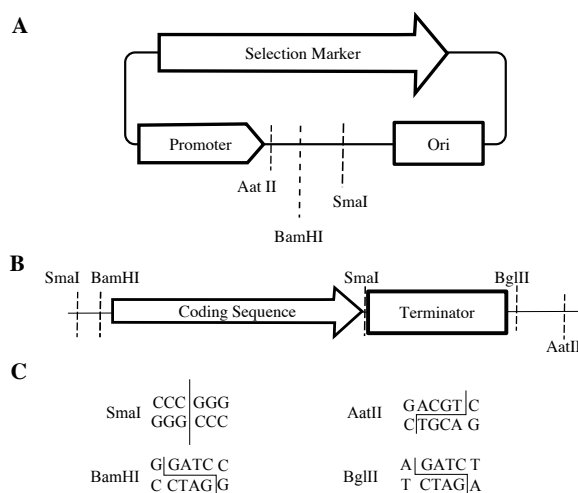

Indicate if each of the following statements is true or false.

TRUE FALSE

Digestion with SmaI followed by ligation can produce the desired recombinant plasmid.

 TRUE FALSE

Digestion with AatII and BamHI followed by ligation can produce the desired recombinant plasmid.

 TRUE FALSE

Digestion with BamHI + BglII followed by ligation can produce the desired recombinant plasmid.

 TRUE FALSE

The 'coding sequence' needs to be in-frame with the promoter

 TRUE FALSE

Solution:

- False**
Cutting the insert with SmaI will separate the coding sequence and the terminator in which case the resulting plasmid will not produce a functional expression plasmid.
- False**
Both insert and plasmid contains unique AatII and BamHI sites. However, they are in reverse order which means that ligation will position the terminator next to the promoter and the 'coding sequence' pointing in the wrong direction relative to the promoter.
- True**
The plasmid contains a single BamHI site allowing us to open the plasmids close to the promoter. The insert contains a BamHI and NdeI site situated on either side of the [coding sequence - terminator] cassette. BamHI and NdeI generate identical overhangs allowing the formation of perfect base pairing between the digested insert and plasmids. The resulting plasmids will have a functional gene that can be expressed.
- False**
The term in-frame relates to codons (triplets) and the promoter does not contain codons.

Q. 17

Yeast (*Saccharomyces cerevisiae*) has a mating pattern with both haploid and diploid cells, mitosis and meiosis, and two kinds of mating types. Haploid cells may even switch mating type (Fig.).

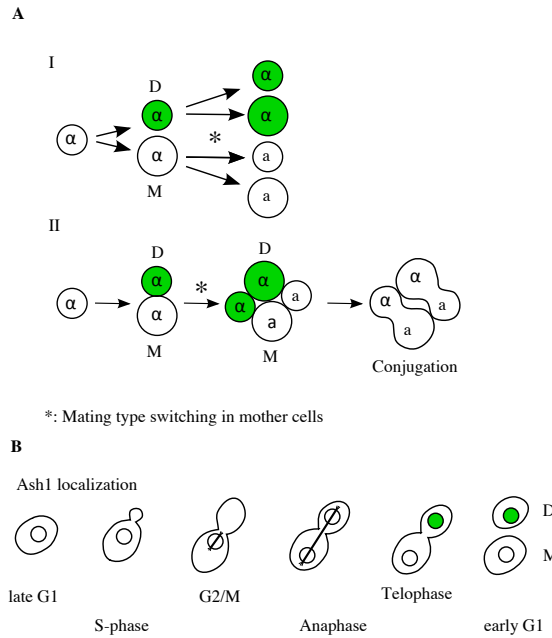

A, mating-type switching in budding yeast (M, mother cell; D, daughter cell, a and α , mating types). Fig. A I, mitosis in haploids; A II, mating and diploid formation; B, budding in haploid yeast. Both in Fig. A and B, green filling indicates the repressor factor protein Ash1p.

Indicate if each of the following statements is true or false.

TRUE FALSE

Mating in yeast can only take place between two different kinds of haploid cells

Mating-type switching occurs only in the mother cell of each haploid generation

Mating type shift is induced by the repressor factor Ash1p

Mating type shift of haploids and the meiosis of diploids result in maximum mixing of mating types

Solution:

1. **True**

Haploid yeast cells exist in either of two mating types, α and a (see Figure A, right column, the green 'conjugation').

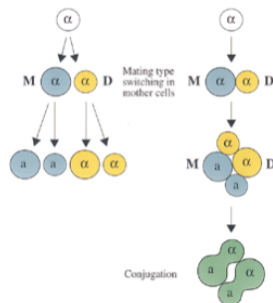

2. **True**

Haploid yeast cells exist in either of two mating types, α and a (see Figure A, right column, the green 'conjugation').

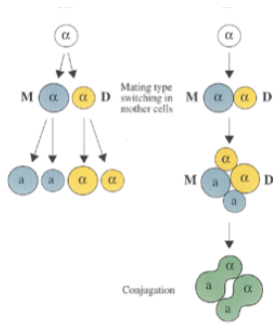

3. **False**

As seen from Fig. A (right column), Ash1p accumulates in a daughter cell, which does not switch mating type. Thus Ash1p must repress this. Ash1p is inhibited in mother cells, allowing them to shift mating type (Fig. B).

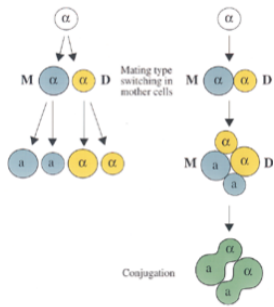

4. **True**

Daughter and mother cells are next to each other, and mothers change mating type. Diploids produce four adjacent spores, two of each type.

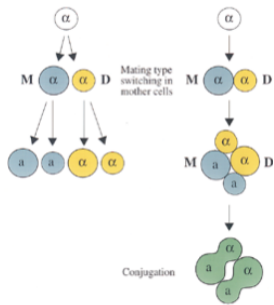

Statin-drugs are used to lower blood cholesterol levels in patients that are at risk for cardiovascular diseases due to elevated blood cholesterol levels. One type of statins functions by inhibiting the *de novo* synthesis of cholesterol (or ergosterol) in eukaryotic cells via competitive binding and inhibition of the enzyme 3-hydroxy-3-methyl-glutaryl-CoA reductase (HMG). This enzyme also exists in *S. cerevisiae* and high concentrations of this group of statins can hence act as fungicides. In the current experiment aimed at identifying genes/enzymes that could make yeast resistant to statins.

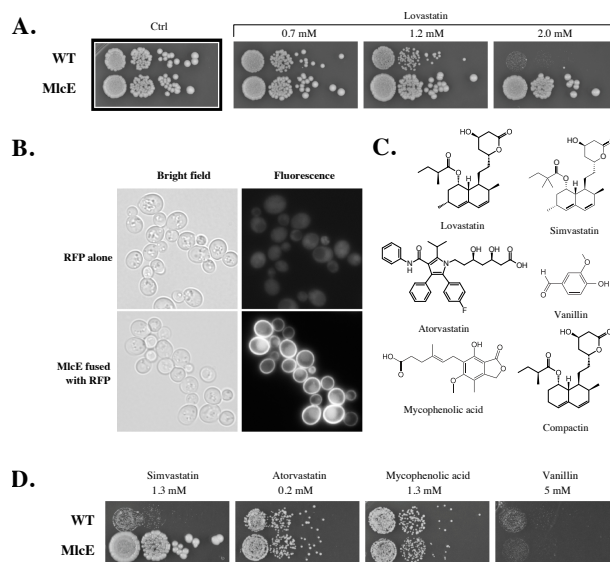

A: An agar plate-based experiment, where a dilution series of two yeast cell cultures (wild type (WT) and MlcE expressing (MlcE)) have been spotted onto agar plates containing different concentrations of the statin lovastatin. The highest cell concentration is on the left of each plate; **B:** Bright field and fluorescence microscopy of yeast strains expressing red fluorescent protein (RFP) alone or RFP fused with MlcE (MlcE-RFP), respectively; **C:** The chemical structure of the compounds tested in A and D; **D:** Plate based-experiment, as described in A, testing different toxic compounds.

Indicate if each of the following statements is true or false.

S. cerevisiae is naturally resistant to the effects of lovastatin up to 0.7 mM

TRUE FALSE

MlcE encodes a protein that localizes primarily to the plasma membrane

The MlcE offers general protection against all tested statins

MlcE will likely also protect yeast from the harmful effects of compactin

Solution:

1. **True**

Astrocytes can produce energy from GLU in critical situations, where level of glucose in the brain is too low.

2. **True**

The brain of the knockout mice needs as much energy as the brains of the control mice. The level of glucose is lower in the brain of control mice indicating a higher decomposition of glucose.

Fig. B/Y-axis: nmol $^{14}\text{CO}_2$ emission/mg protein is a proxy of metabolic rate. Per protein means that it is a proxy of cell/tissue mass. The produced amount of CO_2 monitored by adding an amount of ^{14}C glucose and $^{14}\text{CO}_2$ is measured using scintillation counting.

3. **False**

When KG levels are low because of lack of KG from GLU decomposition, the speed of the (TCA) citric acid cycle is lower (see Fig. A). Production of lactate - involving TCA and glycolysis - might explain the lower emission of $^{14}\text{CO}_2$ from the knockout mice as production of lactate does not involve production of CO_2 .

4. **True**

With lower activity in the (TCA) citric acid cycle, less (NAD⁺ and FAD)/min are reduced in the mitochondria from knockout mice.

 | Q. 19

The amino acid sequence MYTHELL is essential for the activity of a given enzyme. Analysis of this enzyme in three related species (A–C, see statements) reveals some diversity. The table below shows the codon usage for the different amino acids in the three organisms

TTT Phe F	TCT Ser S	TAT Tyr Y	TGT Cys C
TTC	TCC	TAC	TGC
TTA Leu L	TCA	TAA STOP	TGA STOP
TTG	TCG	TAG	TGG Trp W
CTT Leu L	CCT Pro P	CAT His H	CGT Arg R
CTC	CCC	CAC	CGC
CTA	CCA	CAA Gln Q	CGA
CTG	CCG	CAG	CGG
ATT Ile I	ACT Thr T	AAT Asn N	AGT Ser S
ATC	ACC	AAC	AGC
ATA	ACA	AAA Lys K	AGA Arg G
ATG Met M	ACG	AAG	AGG
GTT Val V	GCT Ala A	GAT Asp D	GGT Gly G
GTC	GCC	GAC	GGC
GTA	GCA	GAA Gln E	GGA
GTG	GCG	GAG	GGG

Indicate if each of the following statements is true or false.

TRUE FALSE

In species A, the enzyme-encoding sequence has changed to MTTHYLL, which can be explained by two point mutations

 TRUE FALSE

In species B, the sequence is MYYS, which is best explained by a frame shift mutation

 TRUE FALSE

In species C, the sequence is in fact MYTHELL, but this can be due to 512 different nucleotide sequences

 TRUE FALSE

On average, a change from MYTHELL to MYTQELL is more likely than a change to MYTHEHL

 TRUE FALSE

Solution:

1. **False**

MYTHELL to MTTHYLL

The second amino acid in the sequence has changed from a Y to a T. Two triplets code for Y are TAT and TAC, while four code for T are ACT, ACC, ACA, ACG. The only overlap between the two sets of codons is in the last base (T or C), requiring that the two first change in order to get a change from Y to T, i.e. two point mutations

The third last amino acid in the sequence has changed from an E to a Y. Two triplets code for E (GAA, GAG), and two triplets code for Y (TAT, TAC). The only overlap between the two sets of codons is in the central base (A), requiring that the first and last change in order to get a change from E to Y, i.e. two point mutations.

Thus in total 4 point mutations.

2. **True**

Insertion of a T results in a change from ATGTATACTCATGAATTATTA to ATGTATTACTCATGAATTATTA.

3. **False**

A total of $1 \times 2 \times 4 \times 2 \times 2 \times 6 \times 6 = 1152$ different nucleotide sequences will give the same amino acid sequence.

4. **True**

Both only require a single point mutation to occur.

 | Q. 20

The adenine (A) content in DNA extracted from tissues of horse, donkey, mule and zebra has been determined. A mule is a horse x donkey hybrid. A zonkey is a zebra x donkey hybrid.

	Horse	Donkey	Mule	Zebra
Tissue	Muscle (HM)	Kidney (DK)	Muscle (MM)	Kidney (ZK)
Relative genome size	3.4	4.1	3.7	4.1
Adenine (A) content (%)	25	20	not determined	not determined

Indicate if each of the following statements is true or false.

TRUE FALSE

In the samples **DK** and **ZK**, the A content is likely to be identical

 TRUE FALSE

The A content of **MM** is likely to be approximately the weighted average of **HM** and **DK**, i.e. 23%

 TRUE FALSE

If the A content is 20%, then the G (guanine) content must also be 20%

 TRUE FALSE

The relative genome size of a zonkey is likely to be 4.1

 TRUE FALSE

Solution:

1. **False**

Identical tissues from different species probably never have the same A-amount even if they have identical genome sizes (Knowledge).

2. **True**

The mule (3) is a hybrid of a horse and a donkey. All three species are diploid. The mule will have received half of its chromosomes from its mother (horse) and half from its father (donkey). Though horses and donkeys have different chromosome numbers (32 and 31) the size of their genomes are almost identical. Example: $A\%(\text{donkey}) = 20\%$ and $A\%(\text{horse}) = 25\% \Rightarrow ((4.1/2 \cdot 20\%) + (3.4/2 \cdot 25\%))/3.7 = 22.6\%$.

3. **False**

$A\% = 20\%$; $A\% + T\% = 40\%$; $100 - (A\% + T\%) = 60\%$; so $G\% + C\% = 60\%$; $G\% = 30\%$

4. **True**

The zonkey is a hybrid of a donkey and a zebra. All three species are diploid. The zonkey will have received half of its chromosomes from its mother (donkey) and half from its father (zebra). Donkeys and zebras have identical sizes of their genomes (4.1), so this will be the size for the offspring as well.

Q. 21

Bacteria are the food of many nematodes, and many bacteria have a toxic secretion defence. Nematodes are also preyed upon, e.g. by the fungus *Arthrobotrys oligospora* (*Ao*). This fungus lives in cow dung and is either saprophytic or predatory. When it encounters a nematode, it becomes predatory by producing traps to capture nematodes (Fig. A). This shift is induced by chemicals, e.g. urea produced by bacteria, e.g. *Stenotrophomonas maltophilia* (*Sm*) (bacterial urea production below 300 mg/L soil). The interactions between bacterium, fungus, and nematode were studied (Fig.).

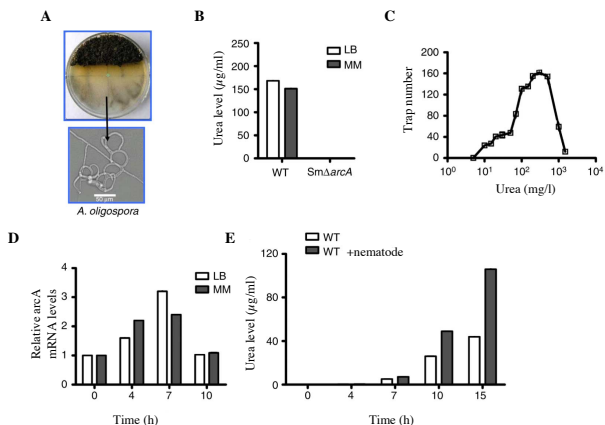

A, trap-formation by *Ao* near cow dung on a plate; B, urea is produced from arginine and formation is catalysed by arginase, being controlled by the gene *arcA*; *SmΔarcA* is a bacterial strain without *arcA* (WT is wild type); LB and MM are nutrient-rich and -poor media, respectively; C, trap number as a function of urea concentration; D, *arcA* is expressed in bacteria, when nematodes are added; E, urea levels in bacteria with and without nematodes. (from Wang et al. 2014).

Indicate if each of the following statements is true or false.
Indicate if each of the following statements is true or false.

TRUE FALSE

Under normal conditions of bacterial urea production, trap production by the fungus increases

Only bacteria with the specific gene *arcA* can produce urea

Bacteria produce urea in both nutrient-rich and -poor conditions

Urea production seems to be triggered by stimuli from the nematode

Solution:

1. True

The aim of this question is to test students' ability to summarize the information about a complicated predator-prey system.

Trap production peaks at mid-urea levels ($5 \times 10^2 \text{ mg L}^{-1}$) (Read from Fig. C).
Intro says up to 300 mg/liter soil.

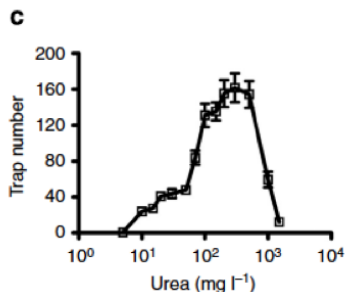

2. True

Seen in Fig. B, where *SmDarcA* is a bacterial strain, which does not produce arginine and thus no urea.

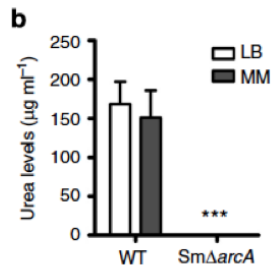

3. True

Figs B and D. Comparison of black and white bars.

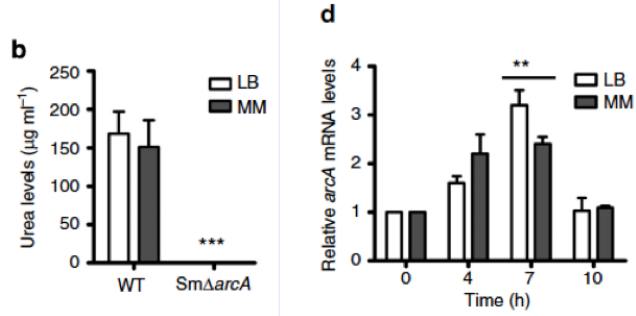

4. True

Fig. E. Black bars (WT + nematode) are significantly higher than white bars (WT, no nematode).

Reference

Wang, X. et al. 2014. Bacteria can mobilize nematode-trapping fungi to kill nematodes. *Nature Communications* 5:5776/DOI: 10.1038/ncomms6776.

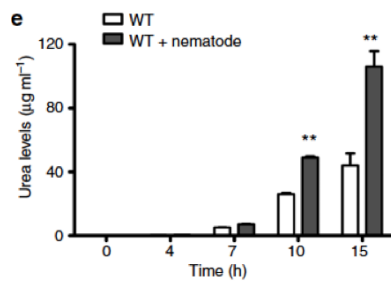

Differentiation of a kind of stem cells (mesenchymal stromal cells MSC) derived from adipose rat tissue (A-MSC) and bone marrow (B-MSC) was analyzed *in vitro* and *in vivo*. Diabetic rats (STZ rats) were used and MSCs were co-transplanted with pancreatic islets to confirm the *in vitro* results (Fig. A).

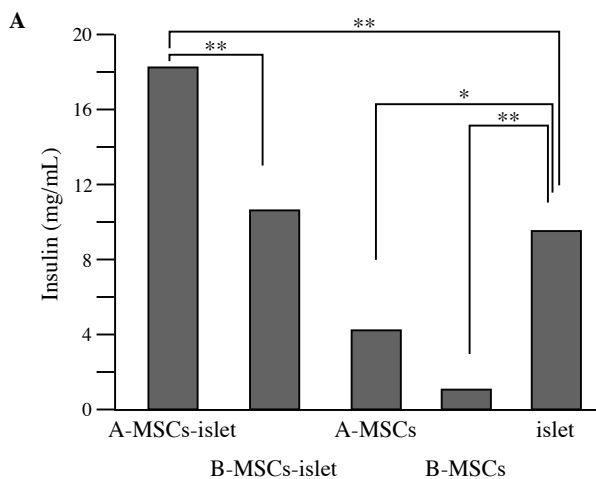

A. *in vitro*: insulin secretion levels after 38 days of culture of islets and stem cells

The insulin-producing capacities of the islets transplanted with stem cells were compared and reduction of hyperglycemia symptoms in the rats was examined (Fig. B-C).

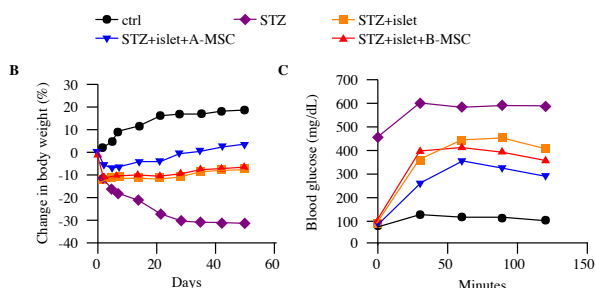

B. *in vivo*: body weight change after transplantation of islets into the rats. Body weight change (%) compared to the time of transplantation (day 0); C. *in vivo*: Glucose tolerance test was performed after injection of 2 g glucose/kg rat (from Karaoz et al. 2013).

Indicate if each of the following statements is true or false.

There is no added advantage in cultivating pancreatic islets together with stem cells in order to obtain a high insulin production *in vitro*

TRUE FALSE

Transplanting stem cells and islets may potentially reduce the blood glucose level in a glucose tolerance test, but not to the level observed in control rats

Transplantation of stem cells from adipose tissue together with islets seems to be the most efficient way to help people, who suffer from diabetes

The conclusion from all experiments is that there are no observed effects of islets + bone marrow stem cells together as compared to islets alone

Solution:

1. **False**

The aim of this question is to test students' ability to draw some simple conclusions from a technically difficult study.

The results in Figure A show that the combinations of stem cells and islets give a much higher yield of insulin.

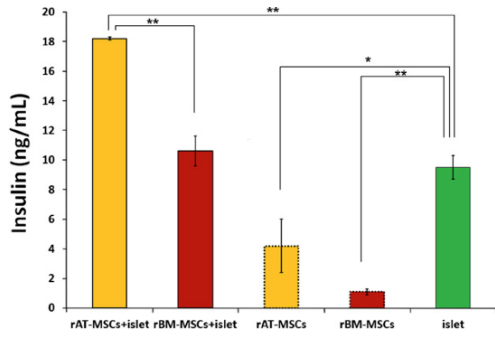

2. True

The results in Figure A show that the combinations of stem cells and islets give a much higher yield of insulin.

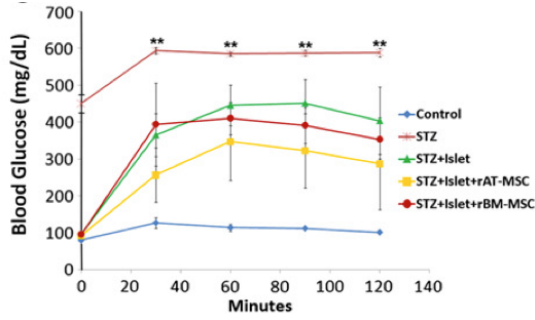

3. True

Indeed this combination seems to be the best way to stabilize body weight (yellow curve in Fig. B). If the results are transferable to humans this might help persons suffering from diabetes.

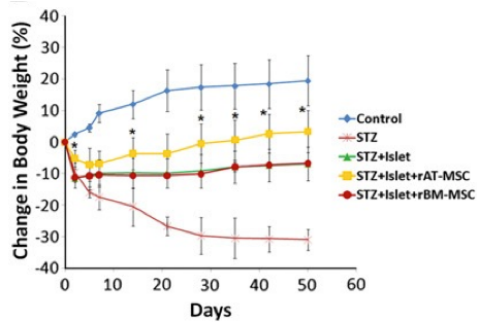

4. True

No difference in secretion of insulin (red vs. green bar, Fig. A)

No improved performance in the Glucose tolerance test (red vs. green curve, Fig. C).

No difference in the change in body weight (red curve: islets + rBM-MSC; green curve: islets alone, Figure B).

Reference

Karaoz, E. et al. 2013. Adipose tissue-derived mesenchymal stromal cells efficiently differentiate into insulin-producing cells in pancreatic islet microenvironment both in vitro and in vivo. *Cytherapy* 15(5): 557-70.

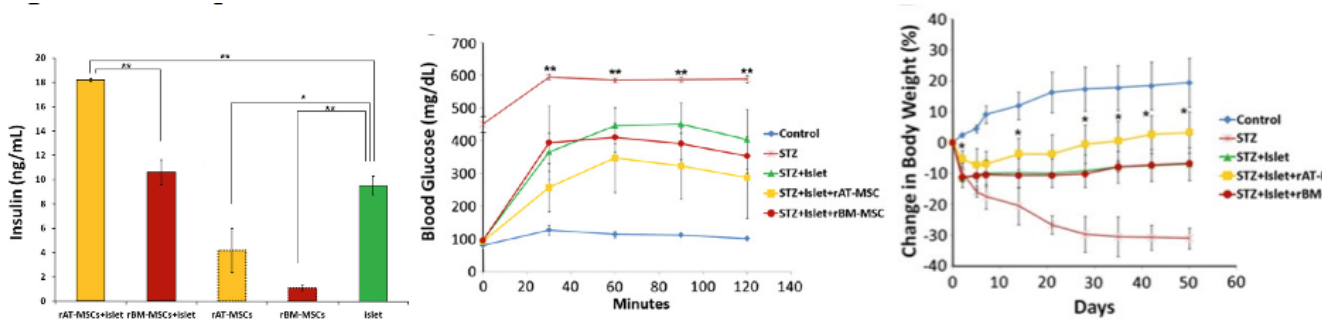

Q. 23

Researchers succeeded in reprogramming human somatic cells into embryonic stem cells (ESC) by a somatic cell nucleus transfer (SCNT) into oocytes from which the nucleus had been removed. After the transfer, the origin of the nuclear and mitochondrial (mt) DNA were analysed (Fig).

Nuclear DNA genotyping from three nucleus transfer (NT)-ESC lines (NT1-3) determined by microsatellite analysis; D2S1333 and D4S413 are locus names and numbers in columns are sequence length of specific alleles.

Origin	D2S1333 locus	D4S413 locus
Somatic donor cell	293/301	123/123
Oocyte	297/305	133/153
NT1	293/301	123/123
NT2	293/301	123/123
NT3	293/301	123/123

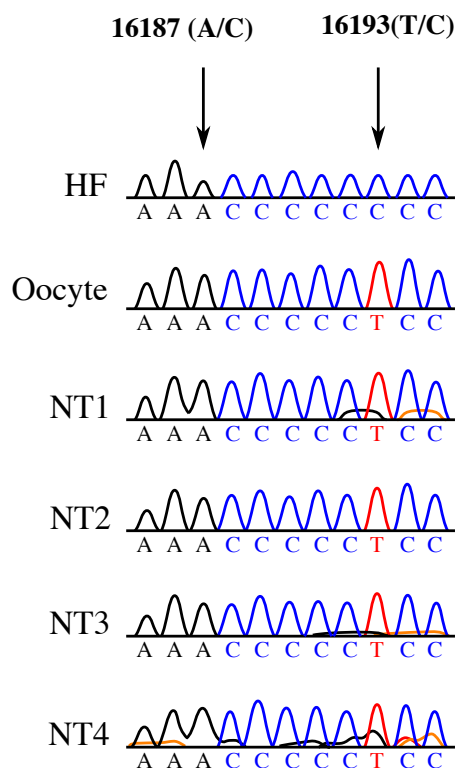

mtDNA sequences of the NT-ESC lines (HF = human foetus); 16187 and 16193 are two nucleotide positions used as markers after SCNT (from Tachibana et al. 2013).

Indicate if each of the following statements is true or false.

The nuclear DNA composition of the ESCs is a combination of nuclear DNA from the somatic donor cell and nuclear DNA from the oocyte donor

The mtDNA of the ESC lines originates from the oocyte

After nuclear transfer the oocyte becomes a haploid

It is most likely, that different oocyte donors were used

Solution:

1. **False**

The aim of this question is to test students' ability to

TRUE FALSE

As can be seen in Fig. A, the genotypes correspond solely to the somatic donor cell, but not to the nuclear DNA of the oocyte.

Origin	D2S1333 locus	D4S413 locus
Somatic donor cell	293/301	123/123
Oocyt	297/305	133/153
ESC-NT1	293/301	123/123
ESC-NT2	293/301	123/123
ESC-NT3	293/301	123/123

2. True

The markers in Fig. B show that they originate from the oocyte. A and T are shared between oocyte and ESC lines, whereas the HDF-f has a C in these two positions. Thus the mtDNA is from the oocyte, whereas the nucleus is from the somatic donor.

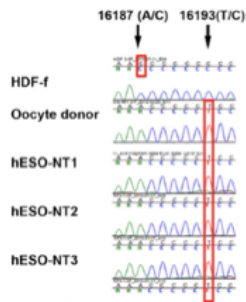

3. False

The oocyte receives a diploid nucleus from the donor.

4. False

Highly unlikely since the sequence of mtDNA is the same in all three ESC lines (Fig. B).

Reference

Tachibana, M. et al. 2013. Human embryonic stem cells derived by somatic cell nuclear transfer. *Cell* 153, 1228–1238.

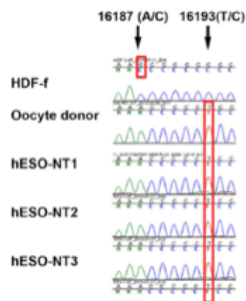

Q. 24

Tropical forest plant communities are very diverse. The Janzen–Connell hypothesis argues that insect herbivores and pathogens are positive drivers of this diversity. This was tested in a rainforest by excluding herbivores and pathogens through pesticide application and observing if this affected plant diversity and abundance (Fig.).

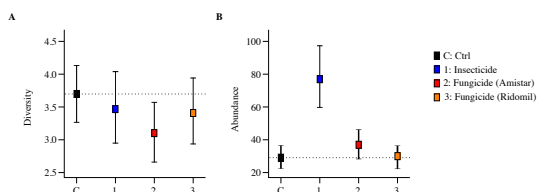

Effects of an insecticide and two fungicides upon: seedling diversity (A) and mean seedling abundance (B) of the forest community. Error bars represent 95% confidence intervals of the mean of all study sites with a given treatment (from Bagchi et al. 2014).

Indicate if each of the following statements is true or false.

TRUE FALSE

All treatments had a statistically significant effect upon seedling diversity

TRUE FALSE

In the study area, most insects were predators

TRUE FALSE

Ridomil is stronger in its effects on fungi than Amistar

TRUE FALSE

The hypothesis is supported in the present study by the combined effect of insects and fungi

TRUE FALSE

Solution:

1. False

The idea of the question is to ask student to evaluate the significance of the results of an experiment, using confidence limits.

NB: First, there is a myth that when two means have confidence intervals that overlap, the means are not significantly different (at the $P < 0.05$ level, all comparisons here). Another version of this myth is that if each mean is outside the confidence interval of the other mean (Control vs. Amistar), the means are significantly different. Neither of these is true; it is easy for two sets of numbers to have overlapping confidence intervals, yet still be significantly different by a two-sample t-test; conversely, each mean can be outside the confidence interval of the other, yet they're still not significantly different.

Here, it is very unlikely that the insecticide and Ridomil differed from the control, but much more likely that Amistar did.

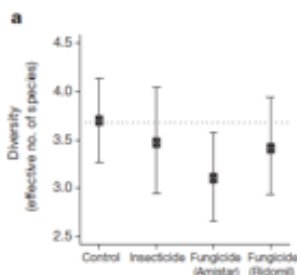

2. False

Insect herbivores do not change seedling diversity significantly (Fig. A), but they decrease overall abundance (abundance increases in plots treated with insecticide, Fig. B). That means, that it is most likely that all plant species are attacked by insects (if not, then diversity would change). Thus insects are generalists, and not specialists.

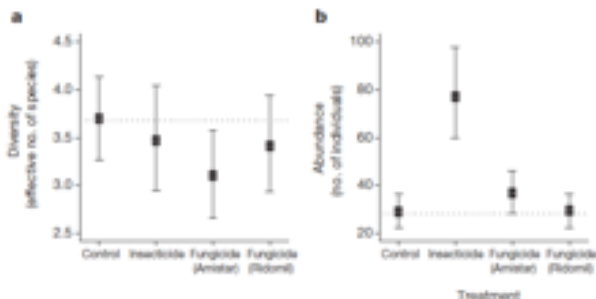

3. False

Ridomil has a weaker effect on the fungi diversity and abundance than Amistar (Figs A and B).

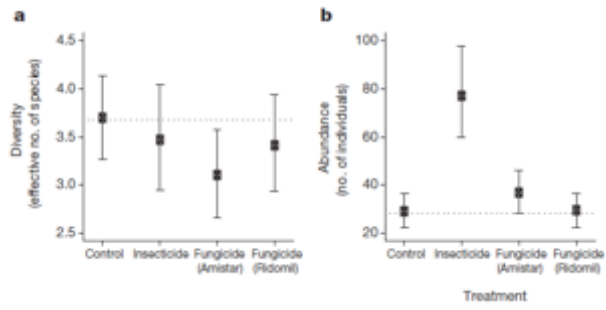
4. **False**

The study does not include a treatment of both insecticide and fungicide (which is quite strange for paper published in Nature!).

Reference

Bagchi, R., Gallery, R. E., Gripenberg, S., Gurr, S. J., Narayan, L., Addis, C. E., Freckleton, R. P. & Lewis, O. T. 2014. Pathogens and insect herbivores drive rainforest plant diversity and composition. *Nature* 506: 85-88.

Q. 25

The fragility of an ecological food chain is examined on an atoll, where native forest was replaced by coconut palms (Fig.). This created a problem for seabirds which could not nest in palms.

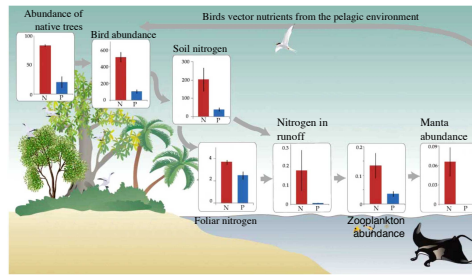

Changes in the ecological chain, when native forest (N) is replaced by palms (P). Each bar graph compares processes in N and P (from McCauley et al. 2012).

Indicate if each of the following statements is true or false.

TRUE FALSE

Bird presence benefits manta rays

TRUE FALSE

Palm growing might harm corals in the atoll

TRUE FALSE

If forest was cleared and land instead used for intensive modern farming with fertilizers, manta rays might disappear from the coast

TRUE FALSE

The food chain includes only top-down effects, and no bottom-up effects

TRUE FALSE

Solution:

1. True

Manta rays = *Manta* spp.

The idea of this question is to make deductions about cascading effects through long food chains and to make predictions about effects of changes.

They do so in two ways: 1: as illustrated by the long chain figure (left), and 2: by eating fish in the coastal water (left), reducing predator pressure on zooplankton and thus relaxing the competition between zooplankton-consuming fish and manta rays.



2. False

Palms cause birds to disappear, reducing the outlet of nitrogen, which further reduces phytoplankton growth, which should increase transparency of lagoon water, increasing the photosynthetic rate of the symbiotic algae of corals.

More palms

less N from Guano

less phytoplankton

more transparency in lagoon

more photosynthesis by symbiotic algae in corals

3. False

Modern farming would use artificial fertilizers and there would be a runoff of nitrogen to the surrounding seas, restoring the N-leaching from bird guano. This would benefit phytoplankton and zooplankton, and thus ultimately manta rays.

Modern farming

artificial fertilizers

more N-run off

more phytoplankton

more manta rays

4. **False**

The effect of vegetation on bird presence is a bottom-up effect, and so are the effects of plankton on mantas.

Reference

McCauley, D. J., DeSalles, P. A., Young, H. S., Dunbar, R. B., Dirzo, R., Mills, M. M. & Micheli, F. 2012. From wing to wing: the persistence of long ecological interaction chains in less-disturbed ecosystems. *Scientific Reports* 2:409, DOI: 10.1038/srep00409.

Q. 26

The World Health Organisation (WHO) recommends a Maximum acceptable Daily Intake (MDI) of 0.1 microgram Hg (Mercury) per kg consumer body mass. Consequently, Hg levels in Danish fish for human consumption are under permanent control. Mercury level in nine species was measured (Fig.).

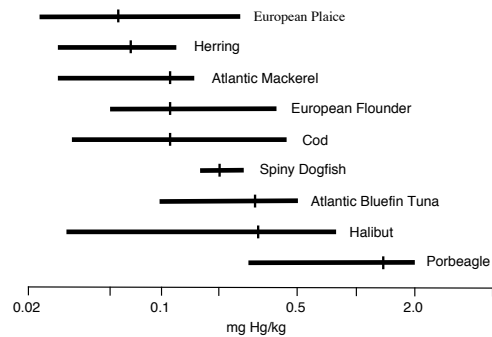

Hg level in milligram/kg fish; horizontal bars span the 95% confidence interval (small vertical bars are averages).

Indicate if each of the following statements is true or false.

TRUE FALSE

Mackerel is placed higher in the marine food chain than Halibut

TRUE FALSE

Hg-level generally increases with body weight

TRUE FALSE

Mean Hg concentration in Tuna allows a 75 kg person to consume a maximum 1 kg Tuna per ca. 10 days

TRUE FALSE

Tuna has a wider diet than Halibut

TRUE FALSE

Solution:

1. **False**

European Plaice
Herring
Atlantic Mackerel
European Flounder
Cod
Spiny Dogfish
Atlantic Bluefin Tuna
Halibut
Porbeagle

The idea of this question is to test students' general knowledge about food chains and bioaccumulation and their ability to some reasoning about body size and human daily intake with respect to Hg.

Halibut has a higher Hg concentration than Mackerel. Since Hg is a heavy metal, we expect this to result in bioaccumulation. Thus we would expect Halibut to be higher in the food chain than Mackerel (Halibut is also larger (another indication of a higher trophic position, but body mass is not included here)).

2. **True**

Larger fish species are expected to have higher age, because body mass and maximum age are positively correlated, and higher age means more time to accumulate Hg (Knowledge)

3. **False**

In Tuna, mean Hg concentration is approx. 0.35 milligram/kg = 350 microgram/kg.
A 75-kg person may max. consume 0.1 microgram/kg body mass/day x 75 kg = 7.5 microgram/day.
Thus a person may eat 1 kg tuna every $350/7.5 = 40$ days, i.e. only 1/4 kg per ca. 10 days.

4. **False**

The Halibut changes completely diet with age from plankton, to crustaceans and to fish of increasing size. This is reflected in the large variation in Hg level (see Fig.) compared to the Tuna.

Q. 27

Large herbivores have a high impact upon ecosystems, but most have become extinct during the last 100 kY (1kY = 1000 years). This mass extinction also affected their associated dung beetle fauna. Subfossil findings in Northern Europe show that this beetle fauna was richer and belonged to more open woodland before the mass extinction than afterwards, when dung beetles became fewer and most lived in closed forest. Modern humans and agriculture arrived to Northern Europe 50 kY and 10 kY ago, respectively.

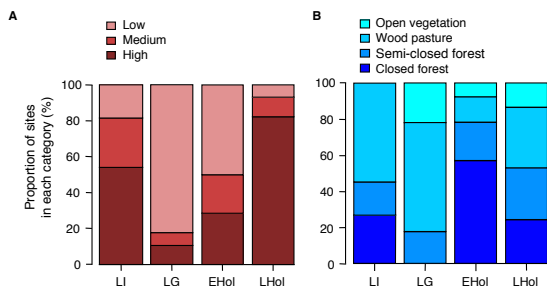

Proportions of excavation sites classified according to their fossil dung beetle density (A), and vegetation type (B); the latter being identified by its characteristic beetle fauna. LI, last interglacial period (132–111 kY ago); LG, last glacial period (50–15 kY ago); EHol, early Holocene (10–5 kY ago); and LHol, late Holocene (2 kY ago to present) (from Sandom et al. 2014).

Indicate if each of the following statements is true or false.

The decline of the large herbivore fauna during LG might partly be explained by climate change

The decline of the large herbivore fauna during LG might partly be explained by human arrival

The small increase in dung beetle density during the warmer EHol is due to a return of large native herbivores after the LG

The strong increase in dung beetle density during LHol is due to agriculture

TRUE FALSE

Solution:

1. True

The idea of this question is to test the students' ability to extract the necessary information from the two figures in order to construct the landscape and faunal history of Northern Europe since the last glacial period.

During the glacial period LG, the number of rich beetle sites declined (Fig. A). This means a decline in large herbivores. Thus there might be a connection between a colder climate and the decline of large herbivores.

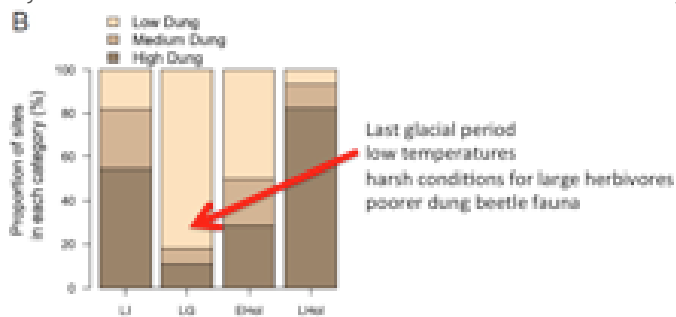

2. True

LG began around 50,000 years ago (Figure legend), which is the estimated time for arrival of modern humans to Northern Europe (intro text).

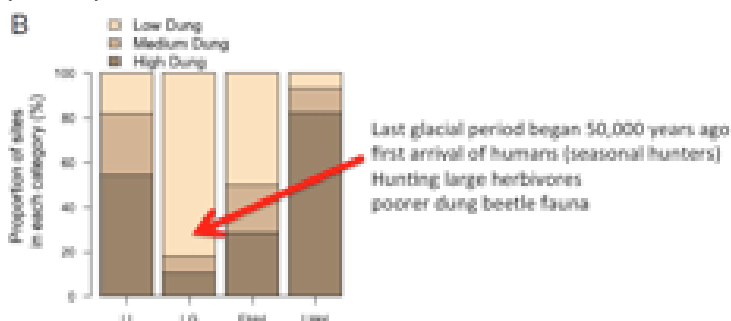

3. **False**

During LG, large herbivores went extinct (Fig. B: fewer beetles). Thus after LG, there are very few large herbivores. The small increase in dung beetles (Fig. A) is due to the first domestic animals and the few surviving large herbivores (intro text).

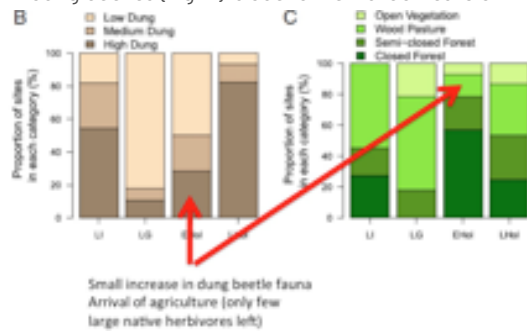

4. **True**

Agriculture encompassed a spread of domestic animals in all kinds of habitats, and their dung favoured a new increase in dung beetles.

Reference

Sandom, C. J., Ejrnæs, R., Hansen, M. D. D. & Svenning, J.-C. 2014. High herbivore density associated with vegetation diversity in interglacial ecosystems. *PNAS* 111: 4162-4167.

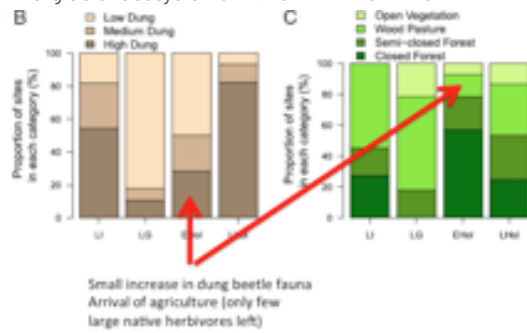

Q. 28

High-altitude Rocky Mountains (U.S.A.) bumblebee communities were studied 40 years ago and again today, and a set of changes was noted, and these were related to climate change (Fig.).

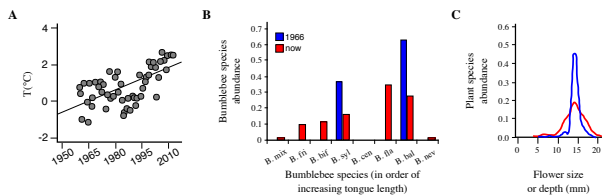

A, change in summer temperature in the Rocky Mountains; B, change in tongue length in a mountain bumblebee community (blue bars, 1966; red bars, now); and C, change in diversity of flowering plant species with different depth, i.e. access to bees, between 1966 (blue) and today (red) (from Miller-Struttman et al. 2015).

Indicate if each of the following statements is true or false.

The present-day bumblebee community is less diverse than in 1966

Higher temperature favours nectar-plant specialist bumblebees

Low-altitude bumblebee species have not been able to invade the higher altitudinal zones during the 40 study years

Average depth of flowers has decreased during the 40 study years, favoring shorter-tongued bumblebees

	TRUE	FALSE
The present-day bumblebee community is less diverse than in 1966	<input type="radio"/>	<input type="radio"/>
Higher temperature favours nectar-plant specialist bumblebees	<input type="radio"/>	<input type="radio"/>
Low-altitude bumblebee species have not been able to invade the higher altitudinal zones during the 40 study years	<input type="radio"/>	<input type="radio"/>
Average depth of flowers has decreased during the 40 study years, favoring shorter-tongued bumblebees	<input type="radio"/>	<input type="radio"/>

Solution:

1. False

The idea of this question is to test the students' ability to draw some general conclusions from a set of figures about climate, community ecology and interactions between bumblebees and flowers.

The white bars are today, and it is seen that there are 7 species today compared to 2 in 1966.

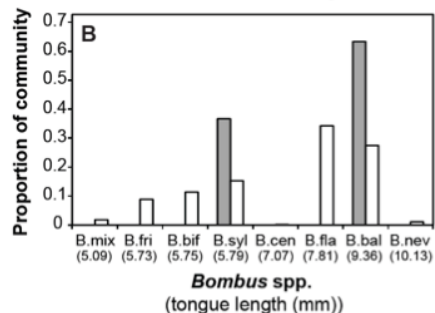

2. False

Today the bumblebee *Bombus balteatus* visit a higher diversity of flowers (from flower depth 4 to 21 mm) than in 1966. That is the increase in temperature seen in Fig. A favours more generalization among bumblebees.

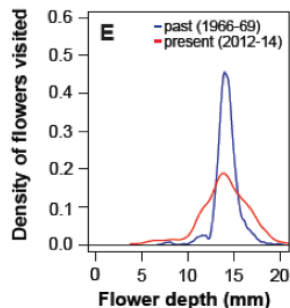

3. False

Five species not present in 1966 are now found in the mountain community. They must have arrived from the lowland.

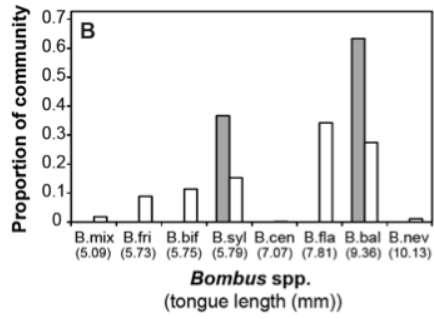

4. False
The figure does not show that. The peak is the same and so is the average.

Reference

Miller-Struttman et al. 2015. The evolution of a functional mismatch in a pollination mutualism under climate change. *Science* in press.

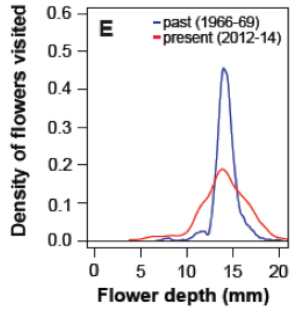

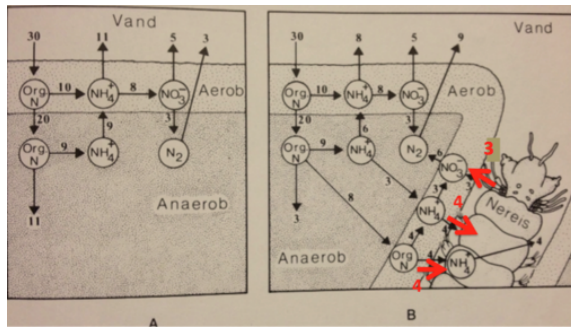

4. False

Fig. A (without *Nereis*): Output to water above sediment: 11 g NH_4^+ + 5 g NO_3^- (assuming that algae cannot use free N_2) = 16 g;
 Fig. B output 8 NH_4^+ and 5 NO_3^- = 13 g, i.e. a reduction from 16 to 13 in the presence of *Nereis*.

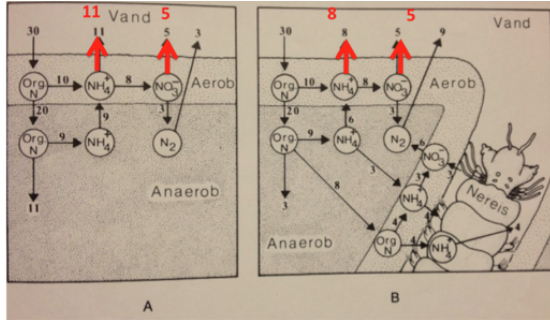

The worm *C. elegans* shows sophisticated behaviour in response to odour. It has 11 pairs of chemosensory neurons. Odours are detected by G protein-coupled receptors (GPCR) on the outside of these neurons. The receptor protein ODR-10 on the neuron AWA initiates the movement of *C. elegans* towards the odour diacetyl (its location shown as X in figure B). The neuron AWB, however, initiates movement away from the toxin nonanone (A).

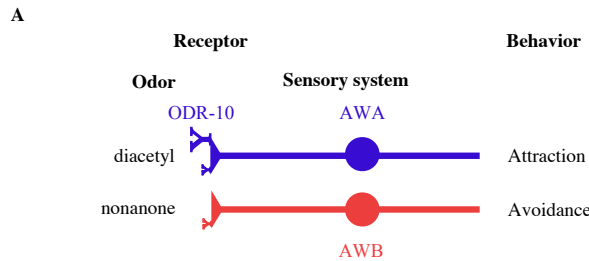

A. diacetyl elicits an attraction (+) of the worm via AWA, nonanone elicits a repulsion (-);

The behaviour of mutant and transgenic worms was compared to the one of wild-type worms (B).

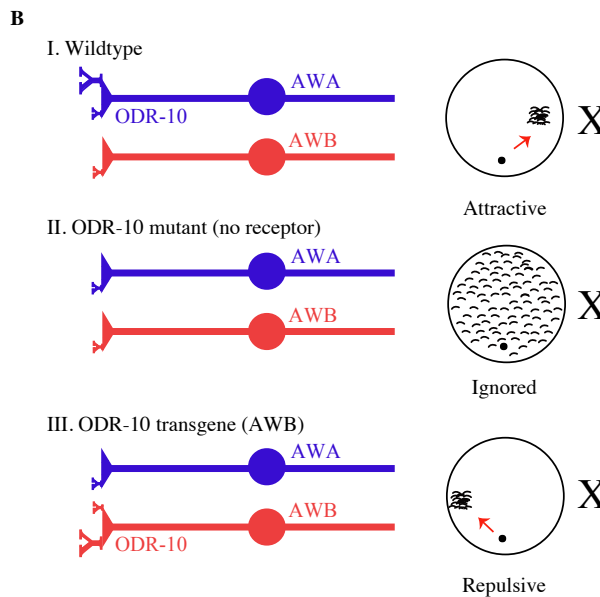

Mutant animals don't express ODR-10. Transgenic animals only express ODR-10 receptors on AWB. The receptor still reacts to the presence of diacetyl, but its reaction is avoidance (-). I. WT = wild type; II, mutant without receptor; III, transgenic animal.

Indicate if each of the following statements is true or false.

TRUE FALSE

ODR-10 on AWA is required for attraction towards diacetyl

TRUE FALSE

ODR-10 can mediate both attraction and repulsion

TRUE FALSE

Each olfactory neuron has receptors for many odour chemicals

TRUE FALSE

All olfactory neurons are functionally similar even if their receptors are different

TRUE FALSE

Solution:

1. **True**

The idea of this question is to test the students' knowledge about cell surface receptors and ability to conclude from the result of a simple experiment.

The mutant worms are not attracted (Fig. B2).

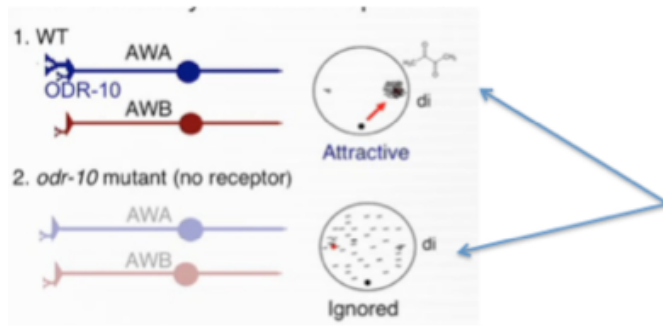

2. True

ODR-10 protein can couple to different signaling pathways in different sensory neurons (Fig. B3). Whether it is attraction or repulsion is determined by the type of neuron.

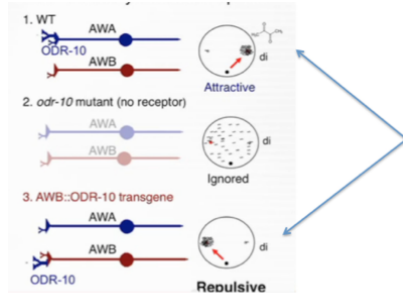

3. True

C. elegans has only two times eleven chemosensory neurons (see intro) and its environment must contain hundreds, perhaps thousands of chemicals, thus each neuron must direct the behaviour towards many compounds.

4. False

Individual olfactory neurons have been shown to detect either attractants or repellents, but not both, e.g. AWB both direct avoidance to nonanone and to diacetyl (if ODR-10 is present), suggesting that there are differences between these cell types. In Fig. C repulsion is connected to neuron type.

Reference

C. elegans chemotaxes to bacteria, its natural food source, by following both water-soluble and volatile cues. Many volatile organic compounds are attractive to *C. elegans* in chemotaxis assays. Most of these attractive molecules are natural products of bacterial metabolism. At least seven classes of volatile odors can be distinguished by *C. elegans* in experiments in which animals migrate to one odor in the presence of a high uniform level of the second odor. Two pairs of amphid sensory neurons, AWC and AWA, are required for chemotaxis to volatile odors. AWA detects at least three (e.g. diacetyl). How are odors recognized as attractive or repulsive? A few volatile organic compounds are repulsive to *C. elegans* at high concentrations. One of these odors, 2-nonanone, is detected in part by the AWB neurons, whose cilia resemble those of AWA and AWC. The G protein-coupled receptor for the attractive odor diacetyl, ODR-10, is normally expressed exclusively in AWA neurons. When ODR-10 is misexpressed in AWB neurons, diacetyl becomes repulsive to the animals. These results suggest that each sensory neuron is preferentially linked to a particular behavioral response: AWA and AWC to attraction, and AWB to repulsion.

More often, *C. elegans* learning paradigms have a mixed character in which the distinction between associative learning and non-associative sensitization, habituation, and adaptation can be blurry.

Habituation is a form of learning in which an organism decreases or ceases to respond to a stimulus after repeated presentations. Essentially, the organism learns to stop responding to a stimulus which is no longer biologically relevant.

Sensitization is a non-associative learning process in which repeated administrations of a stimulus results in the progressive amplification of a response.

Each adult worm has precisely 959 somatic cells, of which almost one-third (302) are neurons. Each neuron is designated with a unique name, typically consisting of three or four letters (e.g., AWA, AWC).

Among neurons, 16 pairs of anatomically bilaterally symmetric neurons (i.e., 32 neurons or ~10% of the nervous system) have been confirmed or inferred to be chemosensory.

These chemosensory neurons respond to a wide variety of soluble and volatile odorants. In a survey of volatile organic compounds, *C. elegans* exhibited either attraction or repulsion to 50 out of 120 compounds tested.

ODR-10, which is required specifically for response to diacetyl, localizes to the tip of the AWA ciliated endings.

What determines if a particular chemosensory neuron drives attractive or repulsive behavior? Normally, AWA neurons drive response to the attractive odorant diacetyl (used as artificial butter odor in popcorn). When AWA neurons are killed with a laser microbeam, *C. elegans* are no longer attracted to diacetyl. AWB neurons, on the other hand, normally drive avoidance responses to the volatile repellent 2-nonanone. When AWB neurons are killed, *C. elegans* no longer avoid 2-nonanone. The G-protein-coupled receptor (GPCR) is the olfactory receptor protein for diacetyl; ODR-10 is normally expressed in AWA neurons, and animals lacking ODR-10 are not attracted to diacetyl. When ODR-10 is heterologously expressed in AWB neurons, transgenic animals are repelled by diacetyl. This suggests that in some cases, sensory neurons are developmentally hard-wired for attractive or repulsive behaviors and their synaptic targets determine the behavioral response.

Attraction to volatile odorants is primarily mediated by the AWA and AWC sensory neurons, and is most likely a part of a general foraging strategy for *C. elegans* to locate bacteria and other food sources. In contrast to soluble attractants such as NaCl, wherein diffusion is limited by the presence of water, volatile odorants that diffuse through the air represent long-distance attractive cues. *C. elegans* responds to a variety of volatile organic compounds, including alcohols, ketones, aldehydes, esters, amines, sulfhydryls, acids, aromatic, and heterocyclic compounds. Using laser ablation, a subset of these odorants has been assigned as being detected by either AWA or AWC. Signal transduction in AWA and AWC neurons both probably involve G-protein-coupled olfactory receptors (Wikipedia).

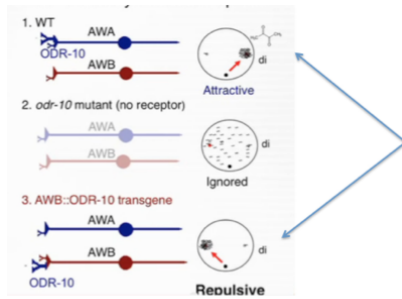

Researchers investigated if street-lighting (artificial night lighting) affected dawn and dusk singing in six common songbirds. They used 5 sets of plots of increasing light intensities (Fig.).

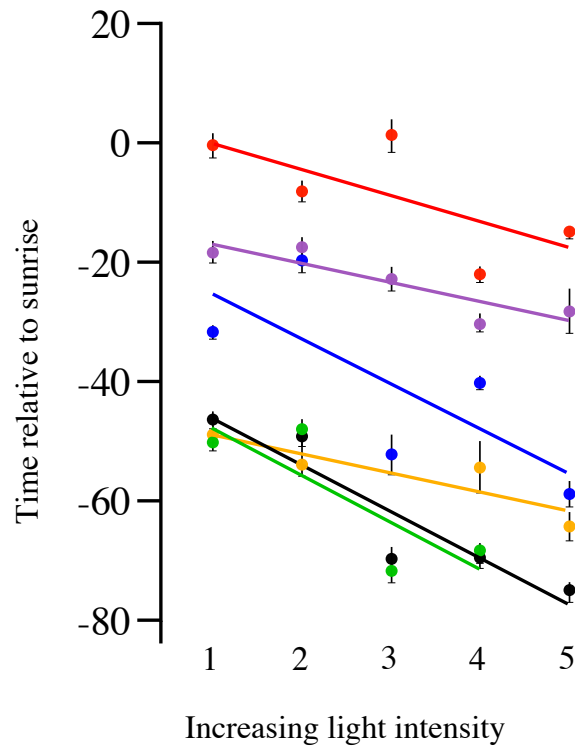

Average start of dawn singing relative to sunrise '0' (mean ± standard error) against increasing light intensity (from 1 to 5) at sites with street-lighting (from Silva et al. 2014).

Indicate if each of the following statements is true or false.

TRUE FALSE

Generally, street-lighting seems to have the strongest effect on the earliest birds

TRUE FALSE

Streetlight increases interspecific competition among birds for time of singing

TRUE FALSE

The morning pattern may be reversed at dusk

TRUE FALSE

Rain at dawn may delay the initiation of singing

TRUE FALSE

Solution:

1. **True**

- (European) Chaffinch = *Fringilla coelebs*
- Blue tit = *Cyanistes caeruleus* or *Parus caeruleus*
- Great tit = *Parus major*
- Song thrush = *Turdus philomelos*
- (European) Robin = *Erithacus rubecula*
- Blackbird = *Turdus merula*

The idea of this question is to test the students' ability to generalize from results in the figure and also to make predictions about dusk singing and "singing in the rain".

In figure, slopes for robin, blackbird and great tit at increasing light intensity are larger than for the other birds. Although being an early bird, the song thrush is not more affected by light than the later birds, that is why I write "Generally" and "seems".

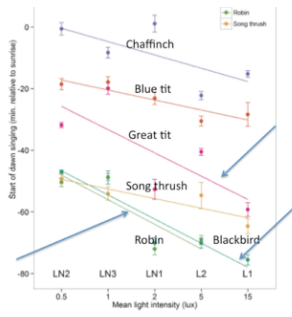

2. False

Streetlight increases interspecific competition among birds for temporal space for singing

The species became more separated in time at the highest light intensities, i.e. separated more in time, i.e. competition must be reduced.

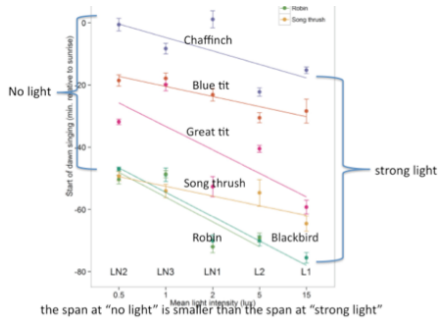

3. True

The researchers showed that, but the effect was smaller. However, the exact order of birds was not the same.

For example the Robin starts singing in the morning at very low light intensity, i.e. it will do the same in the evening, begin to sing when light intensity is very low, i.e. start to sing as the last bird. On the other hand, the chaffinch begins as the last in the morning, when it is very light; thus it may do the same in the evening, begin to sing when it still is very light, i.e. as the first bird.

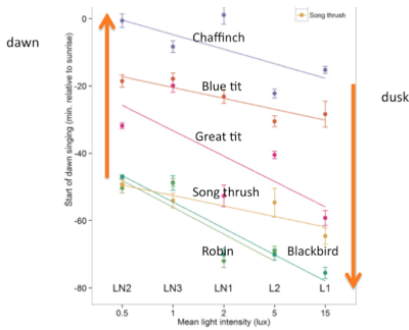

4. True

The light intensity is reduced by rain, imitating an earlier sunset, triggering an earlier start of singing in the evening.

Reference

Silva, A. d., Samplonius, J. M., Schlicht, E., Valcu, M. & Kempenaers, B. 2014. Artificial night lighting rather than traffic noise affects the daily timing of dawn and dusk singing in common European songbirds. *Behavioral Ecology* 25: 1037-1047.

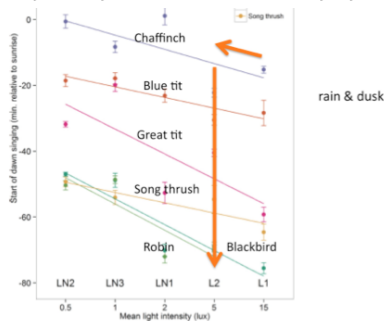

Q. 32

In diploid clover species (*Trifolium*), fertilization is determined by (gametophytic) self-incompatibility alleles (*S*-alleles). Pollen with a given allele, e.g. *S*1, cannot germinate on the stigma of another plant, if this plant has the same allele (e.g. if the mother has the genotype *S*1 *S*2 or *S*1 *S*3), and therefore no fertilization takes place (Fig.). In species with *S*-systems, one often finds many alleles: *S*1 ... etc. in a population.

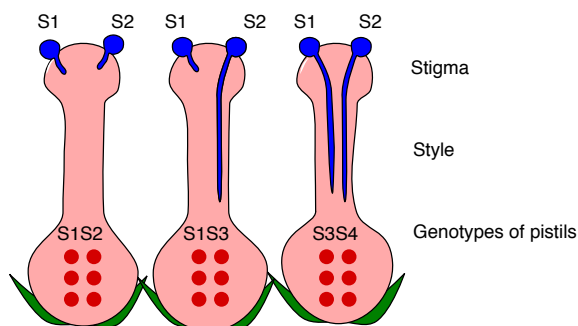

Self-(in)compatibility reactions in three pistils; pollen and pollen tubes are coloured blue. *S*1 to *S*4 are *S*-alleles, and *S*1*S*2 etc. are genotypes of mother plants.

Indicate if each of the following statements is true or false.

TRUE FALSE

The genotypes in the *S* gene are in Hardy-Weinberg equilibrium

TRUE FALSE

In a population with three *S* alleles and equal frequencies of all possible genotypes, 1/3 of all crosses will be incompatible

TRUE FALSE

The smallest possible number of *S* alleles in a viable population is four

TRUE FALSE

In another incompatibility system with only two alleles (*S*1 and *S*2, and *S*1 being dominant over *S*2), 1/3 of all crossing types are compatible

TRUE FALSE

Solution:

1. **False**

The idea of this question is to test students' ability to understand the genetic control of a complex plant breeding system.

The idea of this question is to test students' ability to understand the genetic control of a complex plant breeding system.

2. **False**

Three kinds of pollen *S*1, *S*2 and *S*3, and six genotypes of mothers: *S*1 *S*1, *S*2 *S*2, *S*3 *S*3, *S*1 *S*2, *S*1 *S*3, and *S*2 *S*3:

*S*1 grows on *S*2 *S*2, *S*3*S*3 and *S*2 *S*3 stigmas

*S*2 grows on *S*1 *S*1, *S*3*S*3 and *S*1 *S*3 stigmas

*S*3 grows on *S*1 *S*1, *S*2*S*2 and *S*1 *S*2 stigmas

i.e. 9 compatible crosses out of 3 (pollen types) x 6 (mother plant genotypes) = 0.5.

3. **False**

Pollen of a given haplotype (genotype), e.g. *S*1, can germinate on a stigma only if the flower carries two alleles that are different from the allele of the pollen. Therefore, three alleles is the lowest number of *S*-alleles in a population, i.e. 6 genotypes of plants: *S*1 *S*1, *S*2 *S*2, *S*3 *S*3, *S*1 *S*2, *S*1 *S*3, and *S*2 *S*3.

4. **False**

Mother plants have diploid stigma and because of the dominance of *S*1 over *S*2 have either the phenotype *S*1 (genotype *S*1 *S*1 or *S*1 *S*2) or *S*2 (*S*2 *S*2).

 | Q. 33

In a single locus with three alleles A, B and C, the population allele frequency of A is 0.25 and the frequency of AC individuals is 0.20. We assume random mating in the population.

Indicate if each of the following statements is true or false.

TRUE FALSE

The frequency of the AA genotype will be 0.1875

 TRUE FALSE

The frequency of the AB genotype will be 0.175

 TRUE FALSE

If B is dominant to A and C, then the frequency of the B phenotype will be the frequency of the B allele

 TRUE FALSE

In a single locus with 5 alleles, we get 16 possible genotypes

 TRUE FALSE

Solution:

1. **False**

The idea of this question is to test the students' ability to calculate gene, genotype and phenotype frequencies in a 3-allele locus.

$$p(A) = 0.25$$

$$p(AC) = 0.20$$

$$\text{It will be } p(A)^2 = 0.25^2 = 0.0625.$$

2. **True**

$$p(AC) = 0.20 = 2 \cdot 0.25 \cdot p(C) \rightarrow p(C) = 0.40$$

$$p(C) = 0.40$$

$$p(B) = 1 - p(A) - p(C) = 1 - 0.25 - 0.40 = 0.35$$

$$p(AB) = 2 \cdot p(A) \cdot p(B) = 2 \cdot 0.25 \cdot 0.35 = 0.175.$$

3. **False**

$$P(AA) = 0.0625$$

$$p(AB) = 0.175$$

$$p(AC) = 0.20$$

$$p(BB) = 0.1225$$

$$p(BC) = 0.28$$

$$p(CC) = 0.16$$

However, if allele B is dominant, then the frequency of the B phenotype $p(B_x)$ will be $= 0.175 + 0.1225 + 0.28 = 0.5775$, whereas frequency of the allele B is $p(B) = 0.35$ (see statement 2).

4. **False**

15 is the correct answer

The formula is: (Number of alleles) \times (number of alleles + 1) / 2 = (5 \times 6) / 2 or 15.

Or a more "homemade" calculation: There are 10 heterozygotes (4 + 3 + 2 + 1) = AB, AC, AD, AE + BC, BD, BE + CD, CE + DE; and five homozygotes (the diagonal) AA, BB, CC, DD and EE.

Reference

Campbell et al. 2015. 10th ed. Pp. 548.

 | Q. 34

The oomycete *Hyaloperonospora arabidopsidis* (*Ha*) grows on the plant *Arabidopsis thaliana* (*At*). Six genotypes of *At* (Pyr, Tsu, Sue, Fin, Tch and Gb) were grown with or without *Ha* in four experiments (Fig. A–D). In each experiment, the *Ha* sample differed: one came from a laboratory sample kept for years (B), one was collected in the field in Germany (C), another in France (D). Finally, one experiment (A) used a mix of the three others.

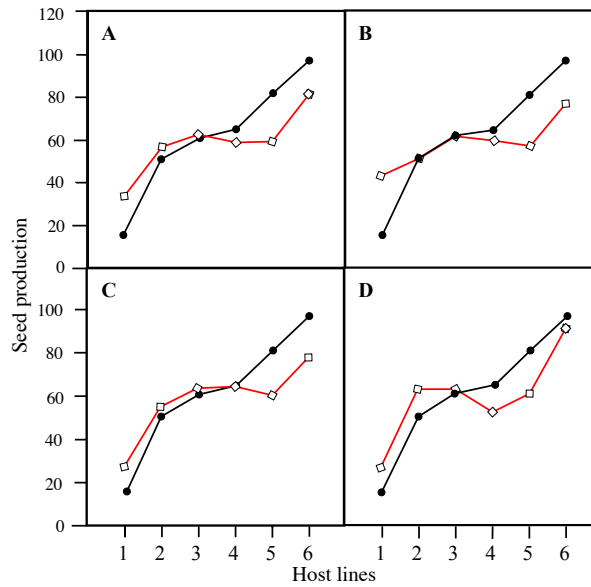

Seed production (mg seeds/plant; Y-axis) of six *At* genotypes (Pyr, Tsu, Sue, Fin, Tch, Gb; X-axis) in four experiments (a)–(d). *At* genotypes are ranked according to increasing seed production in the absence of the oomycetes (filled symbols, black); *At* grown with *Ha* (open symbols, red) (from Salvaudon et al. 2008).

Indicate if each of the following statements is true or false.

TRUE FALSE

In experiment B, *Ha* is commensal with all *At* genotypes

 TRUE FALSE

In experiment C, *Ha* is a parasite on all *At* genotypes

 TRUE FALSE

For all three fungal strains, the negative impact of *Ha* is strongest on the most productive genotypes

 TRUE FALSE

The outcome of interactions between *Ha* and *At* on the plant depends on the latter's genotype

 TRUE FALSE

Solution:

1. **False**
2. **False**
3. **False**
4. **True**

Q. 35

Two pure breeding lines of Species X were crossed (Fig.). For each generation, 100 000 plants were allowed to breed. For the generations F1, F2 and F7, a specified number of plants were genotyped for the alleles *A* and *a*. The experimenter assumes no selection, no self fertilization and random mating after the first generation.

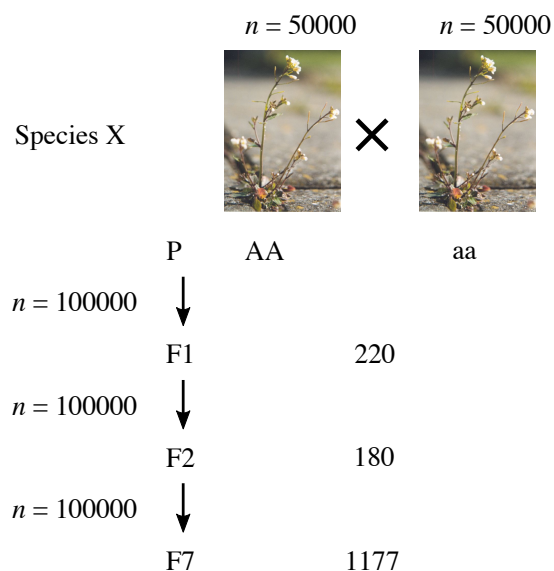

Breeding of pure lines in Species X; n is number of sampled plants. The central column gives number of individuals genotyped in each generation (only generations P, F1, F2 and F7 are shown).

Indicate if each of the following statements is true or false.

	TRUE	FALSE
The parental generation (P) shows Hardy-Weinberg proportions	<input type="radio"/>	<input type="radio"/>
Expected number of <i>Aa</i> genotyped individuals in F1 is 110	<input type="radio"/>	<input type="radio"/>
Expected number of <i>aa</i> genotyped individuals in F2 is 90	<input type="radio"/>	<input type="radio"/>
In F7, 271 plants were genotyped as <i>AA</i> . This is less than expected	<input type="radio"/>	<input type="radio"/>

Solution:

1. **False**

The idea of this question is to analyse a population in Hardy-Weinberg equilibrium.

$p(AA) = p(aa) = 50000/100000 = 0.5$; no *Aa* are observed.

2. **False**

After a cross: *AA* x *aa*, all offspring will be *Aa*. The genotyped sample is 220, and the expected number of *Aa* is then also 220.

3. **False**

After a cross: *Aa* x *Aa*, $\frac{1}{4}$ of the 180 genotyped offspring individuals is expected to be *aa*, i.e. $180 * 0.25 = 45$.

4. **True**

The experimenter assumes no selection (info text), thus the population stays in Hardy-Weinberg equilibrium.

$\frac{1}{4}$ of the 1177 genotyped individuals is then expected to be *AA*

Expected $0.25 * 1177 = 287.5$,

Observed 271.

Q. 36

The phylogeny of seven species is presented in four different ways (Fig.).

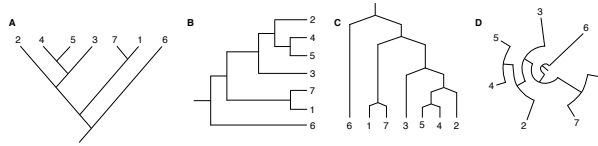

Four phylogenies of seven species (1-7).

Indicate if each of the following statements is true or false.

TRUE FALSE

All four trees reflect the same phylogeny

TRUE FALSE

In all phylogenies, species 6 is expected to have more mutations than species 2

TRUE FALSE

In phylogeny A, species 1, 6, and 7 constitute a monophyletic group

TRUE FALSE

In phylogeny C, species 7 is more closely related to species 3 than to 5

TRUE FALSE

Solution:

1. **False**

The idea of this question is to test students' ability to analyse phylogenies in a phylogeographical context.

All early lines leading to Raninae are ancestors.

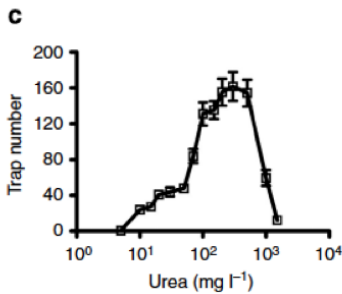

2. **False**

Raninae and Dicroglossinae shared a common ancestor about 100-120 mya.

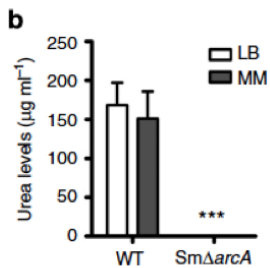

3. **False**

The divergence of Raninae and Nyctibatrachinae most likely occurred 85-95 mya, which overlaps with the 85 mya separation of Madagascar and India.

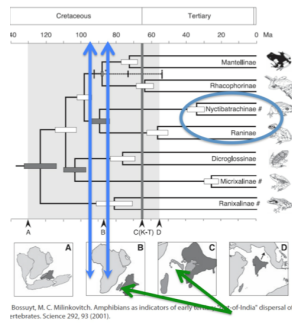

4. **False**

The last common ancestor of Micrixalinae and Dicroglossinae lived 98-110 mya.

Reference

Bossuyt, F. & Milinkovitch, M. C. 2001. Amphibians as indicators of early tertiary "out-of-India" dispersal of vertebrates. *Science* 292: 93.

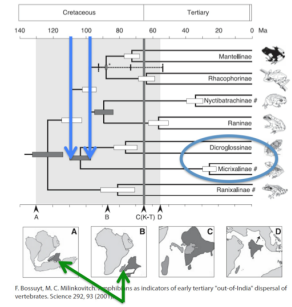

The phylogeny of frogs has a very dynamic geographical history (Fig.).

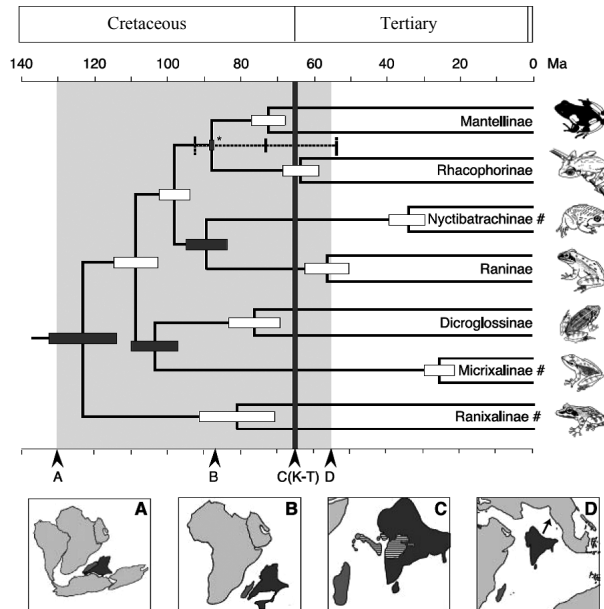

Phylogeny of frog groups (branch lengths proportional to absolute time). Error bars on internal nodes are confidence intervals on the node dates; below and above the phylogeny is a geological time scale, and below the lower time scale is a cartoon for the period between the isolation of the Madagascar-India continental block from Africa (A) (130 mill. years ago, Ma) to the collision of India with Eurasia (D) (56 Ma) (shaded area in phylogeny. A-D in cartoon refer to A-D in lower time scale; K-T = Cretaceous-Tertiary boundary) (from Bossuyt & Milinkovitch 2001).

Indicate if each of the following statements is true or false.

TRUE FALSE

No individual living before 60 million years ago is an ancestor of Raninae

TRUE FALSE

Raninae and Dicroglossinae shared a common ancestor about 75 million years ago

TRUE FALSE

Divergence of Raninae and Nyctibatrachinae most likely occurred after the 85 million year old separation of India and Madagascar

TRUE FALSE

The last common ancestor of Micrixalinae and Dicroglossinae lived before India and Madagascar became separated (85 million years ago)

TRUE FALSE

Solution:

1. **False**

All early lines leading to Raninae are ancestors.

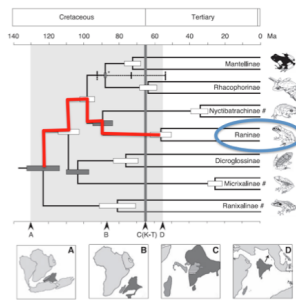

F. Bossuyt, M. C. Milinkovitch. Amphibians as indicators of early tertiary 'out of India' dispersal of vertebrates. Science 292, 93 (2001).

2. **False**

Raninae and Dicroglossinae shared a common ancestor about 100-120 mya.

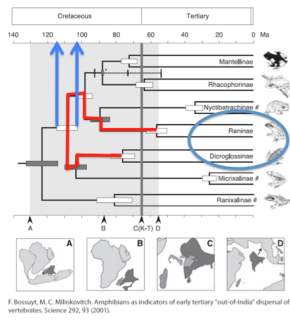

3. **False**

The divergence of Raninae and Nyctibatrachinae most likely occurred 85-95 mya, which overlaps with the 85 mya separation of Madagascar and India.

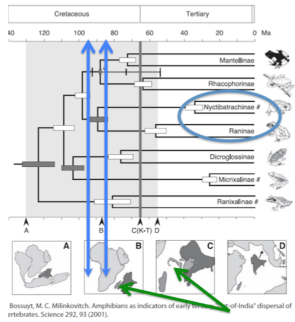

4. **True**

The last common ancestor of Micrixalinae and Dicroglossinae lived 98-110 mya.

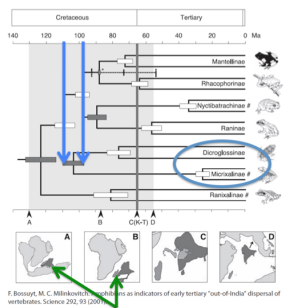

The marine transition area between the Bothnian Bay (the northernmost part of the Baltic Sea between Sweden and Finland) and the Eastern Atlantic ocean is characterized by a steep cline in salinity (Fig. B) and it is inhabited by a number of fish species. Studies show genetic differences, measured as F_{ST} (Fig.) between two populations, one being the Bothnian Bay population, which is considered the reference population. $F_{ST} = 0$ means complete random mating across populations, $F_{ST} = 1$ means no mating between populations.

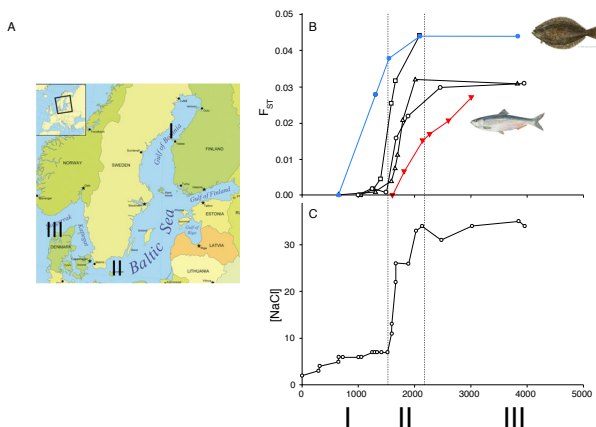

Figure. A, Bothnian Bay (I), Southern Baltic Sea (II), and North Sea (III); B, changes in genetic variation among populations (F_{ST}) of five fish species (blue filled circles = flounder (inset); red filled inverted triangles = herring (inset); open squares, triangles, and circles= three other fish species); C, change in salinity [NaCl] from the Bothnian Bay (I) towards the North Sea (III) (from Limborg et al. 2009).

Indicate if each of the following statements is true or false.

TRUE FALSE

Salinity might be important in shaping the genetic structure of marine fish

TRUE FALSE

Baltic Sea fish are adapted to local environmental conditions

TRUE FALSE

The random mating of Herring is less affected by salinity than is that of the other four species

TRUE FALSE

Flounder is less sensitive to changes in salinity than the other four species

TRUE FALSE

Solution:

1. True

The changes in salinity and genetic differentiation look highly correlated for all five species, which suggests an association.

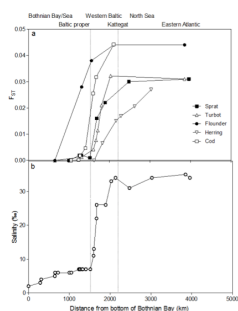

2. True

The large differences in salinity and genetic isolation allow evolution of genetically based environmental adaptation/local adaptation. The steep cline in salinity may operate as a gene flow barrier.

3. True

Herrings have a gradual increase in F_{ST} with distance, and thus do not seem to react strongly to changes in salinity.

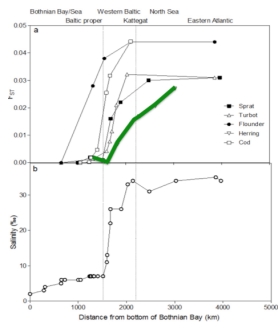

4. **False**

Salinity is a strong barrier to flounder. There are two panmictic populations on each side of the salinity barrier.

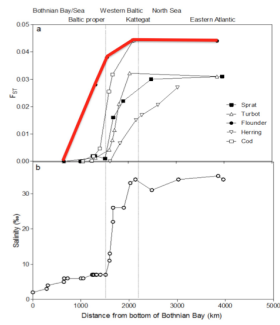

Base sequences of two genomic regions (1 and 2) from blue whale (*Balaenoptera musculus*), sheep (*Ovis aries*) and hippopotamus (*Hippopotamus amphibius*) were aligned and compared (Fig.).

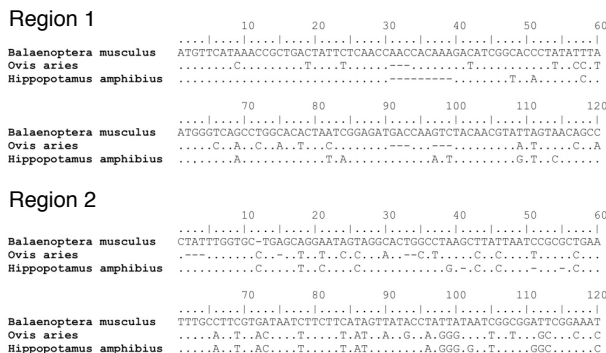

Base sequences: '-' is a base deletion, and '.' means the base is the same as in the sequence above.

Indicate if each of the following statements is true or false.

Region 1 is most likely a protein coding sequence

Region 2 is most likely a protein coding sequence

In region 1, the blue whale sequence is longer than the other two, which suggests that sheep and hippopotamus are closer related than either are to the blue whale

Regions 1 and 2 show the same phylogenetic relationship among the three species

Solution:

1. True

An indel change of a single DNA base encoding part of an mRNA results in a frameshift when translating the mRNA and perhaps reading on to an inappropriate (premature) stop codon in a different frame. Indels that are not multiples of 3 are particularly uncommon in coding regions but relatively common in non-coding regions. All indels in region 1 are of a size of 3 or a multiplum of 3, i.e. not leading to a frameshift. In region 2 there are indels of different size.

There is ATG in the beginning - start codon. But since we do not know if it is a full coding sequence, then start and stop codons do not have to be included.

Region 1

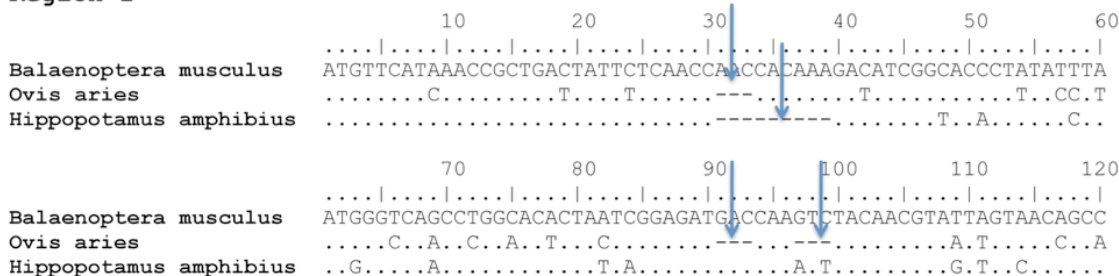

2. False

In region 2 there are indels of different size and thus frame-shifting indels.

Region 2

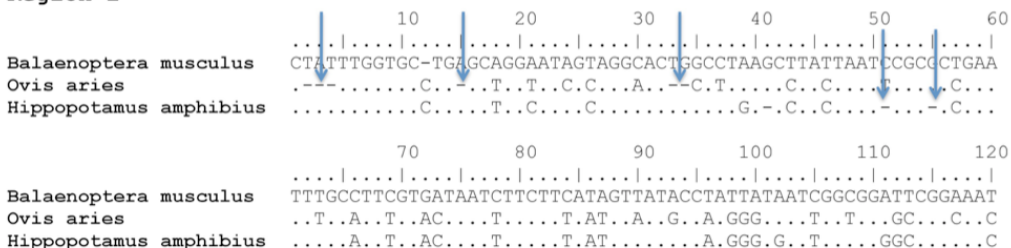

3. False

The 9 bp indel is a single event.

Region 1

	10	20	30	40	50	60
Balaenoptera musculus					
	ATGTTCATAAACCGCTGACTATTCTCAACCAACCAAAAGACATCGGCACCCCTATATTTA					
Ovis ariesC.....T.....T.....-----T.....T.....T.....CC.T					
Hippopotamus amphibius-----T.....A.....C..					
	70	80	90	100	110	120
Balaenoptera musculus					
	ATGGGTCAGCCTGGCACACTAATCGGAGATGACCAAGTCTACAACGTATTAGTAACAGCC					
Ovis ariesC..A..C..A..T..C.....-----A..T.....C..A					
Hippopotamus amphibius	..G.....A.....T.A.....A.T.....G.T..C.....					

4. **False**

Base differences:

	Region 1	Region 2
Blue whale-Hippo	20	28
Blue whale-Sheep	27	39
Sheep-Hippo	32	21

The same results if indels are counted as single events (gap opening og gap penalty).

For region 1: Blue whale-Hippo has the shortest distance
 For region 2: Sheep-Hippo has the shortest distance

 | Q. 40

The fast growing model bacterium *E. coli* (generation time = 20 min) has a single 4.6 million base pair large chromosome that can be replicated in 42 minutes from a single origin of replication.

Indicate if each of the following statements is true or false.

TRUE FALSE

In *E. coli*, DNA polymerase synthesizes about 900 bp/second including proof reading activity.

An *E. coli* cell always contains two copies of its genome just prior to cell division when growing at highest possible growth rate

During replication, the enzyme primase forms a short RNA sequence, which is extended by DNA polymerase. This is why the genome just after replication contains multiple short stretches of RNA

E. coli DNA polymerase III synthesizes DNA with an error rate of 1 wrong nucleotide per 1000 bases, that is why the genome after replication contains about 4600 mutations

Solution:

1. **True**

Calculated as no. base pairs/time/2 (two replications forks moving away from the OriC in opposite directions).
 $4,600,000 \text{ bp} / (42 \text{ min} * 60 \text{ sec} * 2 \text{ two forks}) = 913 \text{ base pairs per second}$ (Partly knowledge: replications forks).

2. **False**

Because the generation time is much shorter (20 min) than the time it takes to replicate the genome (42 min). The cell initiates several replication rounds simultaneously so that it has multiple copies and partial copies of its genome at any time (Knowledge).

3. **False**

The introduced RNA primer is quickly replaced with DNA by DNA polymerase I using its 5' to 3' exonuclease activity (Knowledge).

4. **False**

It is true that DNA polymerase III introduces errors during replication at the given rate, however, the enzyme also processes DNA proof reading activity, which reduces the number of mutations (Knowledge).

A plant crop is susceptible to leaf rust. In a screening of old varieties from a gene bank, a resistance allele *B* was discovered. In an intensive backcrossing program, this allele was introgressed to the crop (Fig.). Resistance was tested in each generation.

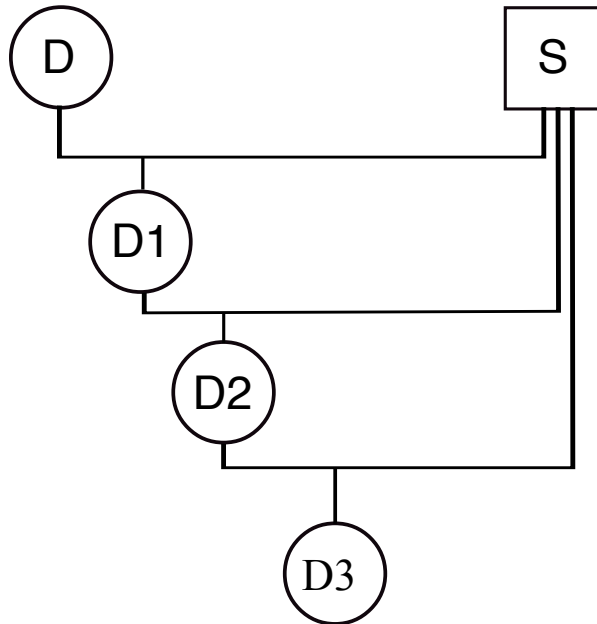

Intensive breeding program. *D* is donor of a dominant resistance allele *B*, and *b* is the allele in the standard crop plant being susceptible to rust. *S* is the variety into which gene *B* is introduced

Indicate if each of the following statements is true or false.

	TRUE	FALSE
93.75% of the alleles, not linked to allele <i>B</i> , in <i>D3</i> come from <i>S</i>	<input type="radio"/>	<input type="radio"/>
At least 10 backcrossings are needed to get the percentage of <i>D</i> genes below 1%	<input type="radio"/>	<input type="radio"/>
More crosses are needed to introgress a recessive resistance allele than a dominant one	<input type="radio"/>	<input type="radio"/>
Introgression cannot be done with quantitative traits	<input type="radio"/>	<input type="radio"/>

Solution:

1. **False**

D1 has 50% (1/2) of its genes from *S* (see figure), *D2* has 75% (3/4) from *S*, and *D3* has 87.5% (7/8).

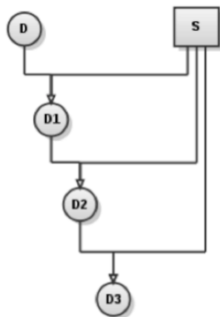

2. **False**

The formula to use is $(1/2)^{n+1} = 0.01$, *n* is number of generations
 $n = 5.6 \approx 6$ crossings (*D1* to *D6*).

The first cross is not a backcross, but a cross between gene donor *D0* and recurrent parent *S*. That is the reason, why *n* is estimated as one generation less, i.e. 6 from *D1* to *D6*, excluding *D0*.

<u>Crossing between genomes</u>	<u>D gene proportion in the genome of seeds from a crossing</u>	<u>S gene proportion the genome of seeds from a crossing</u>
D0 x S	0.5	0.5
D1 x S	0.25	0.75
D2 x S	0.125	0.875
D3 x S	0.0625	0.9375
D4 x S	0.03125	0.96875
D5 x S	0.015625	0.984375
D6 x S	0.0078125 < 0.01	0.9921875

3. **True**

One selfing is needed after each backcross with a recessive trait.
That is not needed for dominant alleles.

4. **False**

It is possible, but more difficult. If done, it is important to be able to select those individuals that, in general, are desirable for genetic reasons, probably somehow to choose an acceptance threshold.

Eelgrass (*Zostera marina*) is a submerged marine plant. During the daytime, O₂ is transported via the aerenchyma of the green parts and rhizomes out into the roots, and an oxygen-rich zone develops in the surrounding anoxic sediment. At nighttime it is a different story: now ethanol diffuses out of the roots and into the sediment (Fig.).

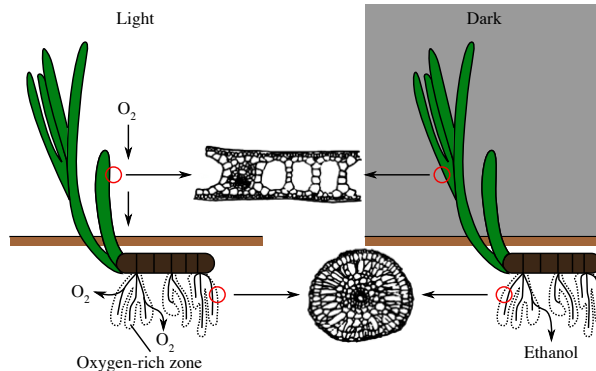

Eelgrass at day and night, and cross-sections of leaf and root.

Indicate if each of the following statements is true or false.

TRUE FALSE

For respiratory reasons, *Zostera* roots are expected to have a thin epidermis

TRUE FALSE

Both at day and night, O₂ readily diffuse into the roots

TRUE FALSE

Root uptake of nutrients is independent of time of day

TRUE FALSE

At nighttime, the concentration of Na⁺ is expected to decrease in root cells

TRUE FALSE

Solution:

1. **False**

It is adaptive to plants to have active root growth. In order to achieve this, a high level of O₂ in roots is required. Thus, one expects a thick epidermis in order to reduce O₂ diffusion and loss out of root at nighttime. This can also (to some extent) be seen on the anatomical figure of the cross section of the root.

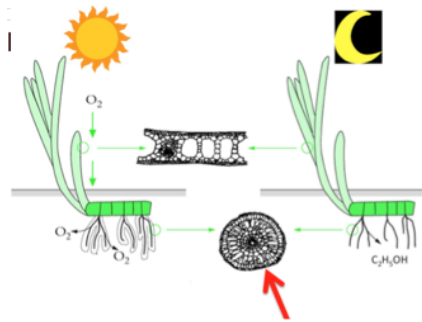

2. **False**

At daytime, the production of O₂ and the [O₂] are sufficiently high to reach the tip of the roots and even to diffuse into the sediment, whereas at nighttime this does not seem to be the case, since ethanol is produced (indicating anaerobic conditions). The reason is, as seen from the figure, that the root tissue is dense and without any aerenchymous lacunae. Thus a steep O₂ gradient is required.

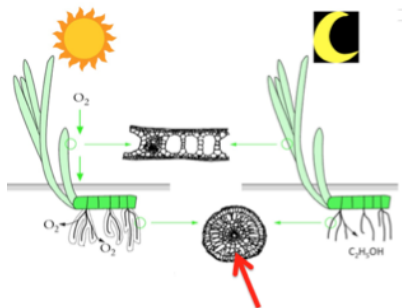

3. **False**

Energy is required for the uptake of NH₄⁺, nitrate etc. and since most ATP is produced at daytime (photosynthetic glucose), the

uptake of nutrients is highest during daytime.

4. **False**

The produced amount of ATP by alcohol fermentation is insufficient to supply the sodium-potassium pump with energy to transport Na^+ out of cells and K^+ in. Thus intracellular $[\text{Na}^+]$ increases.

Q. 43

Crassula helmsii is a successful aquatic plant with CAM photosynthesis. In a cross-factorial study, including 2 light levels: LL and HL; and 2 CO₂ levels: LC and HC, the CAM activity of *C. helmsii* was measured (Fig.).

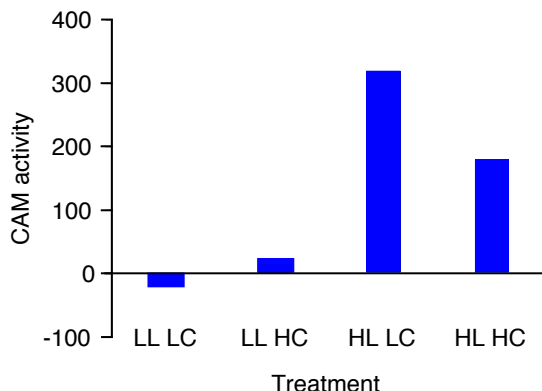

CAM activity measured as dry matter production in plants. LL and HL = low and high light, resp. LC and HC = low and high CO₂, resp. (from Klavsen & Maberley 2010).

Indicate if each of the following statements is true or false.

	TRUE	FALSE
CAM seems to be an adaptation to survive in waters rich in carbon	<input type="radio"/>	<input type="radio"/>
The circadian stomatal opening rhythm of CAM plants enables them to take up CO ₂ at nighttime	<input type="radio"/>	<input type="radio"/>
CAM increases nighttime photorespiration	<input type="radio"/>	<input type="radio"/>
At LL, there is less dry matter production, because CAM plants also require light for photosynthesis	<input type="radio"/>	<input type="radio"/>

Solution:

1. **False**

Crassula did best in the HL/LC treatment, i.e. high light and low CO₂. CAM plants are able to take advantage of elevated nighttime CO₂ levels (from all the surrounding respiratory processes in the environment), because they have open stomata. This gives them a competitive advantage over non-CAM species that are carbon starving during the day (competition for C with other submerged plants for photosynthesis). Some aquatic CAM plants are even common in highly infertile lakes, where extreme carbon limitation is an important selective factor.

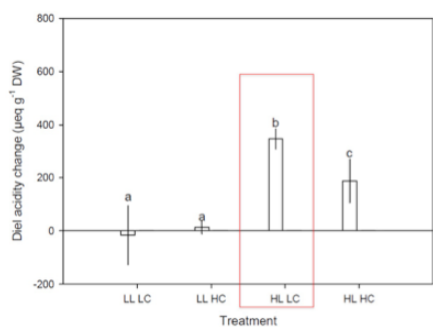

2. **True**

CAM plants close their stomata during the day and open them during the night, which makes it possible to take up CO₂ at nighttime – see statement 1 (Knowledge).

3. **False**

During the night, the uptake of CO₂ and the increased concentration of CO₂ in cells reduce respiration.

4. **True**

CAM plants have open stomata at nighttime and take up CO₂, and use the CO₂ to produce organic acids, and during the day, CO₂ is again released and enters the light-driven Calvin cycle.

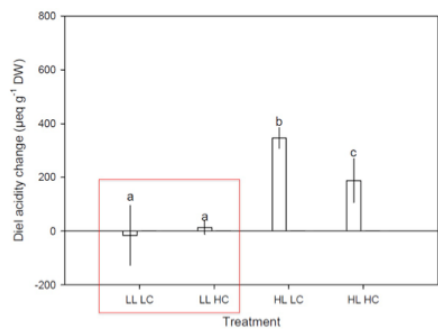

Plants compete as pollen donors for siring offspring, i.e. becoming fathers. The stigma becomes an arena, where pollen donors/fathers “fight” for fertilization (paternity), and where the females “choose” fathers of their seeds. This was studied in the plant Purple Chinese Houses (*Collinsia heterophylla*) (Fig.).

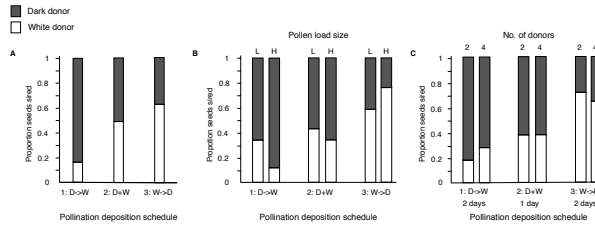

Proportion of seeds sired by either a dark (D) or a white pollen donor (W): A, pollen deposited on stigma in succession (1: D→W, i.e. first D and then W, or 3: W→D) or simultaneously as a mixture (2: D+W); B, size of deposited pollen load (D and W added simultaneously); L and H = low and high pollen load, respectively; and C, two or four donors (i.e. first 2D and then 1–2 days later 2W or vice versa) (from Lankinen & Madjidian 2011).

Indicate if each of the following statements is true or false.

TRUE FALSE

There is a first-donor advantage

TRUE FALSE

No competitive effect of high pollen load is observed

TRUE FALSE

Increase in number of fathers increases competition

TRUE FALSE

If lots of pollen from the first donor is deposited, pollen added 2 days later from a second donor does not sire seeds

TRUE FALSE

Solution:

1. True

This is seen in all the figures.

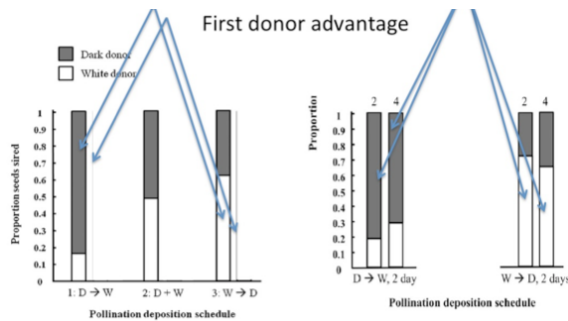

2. False

Competition increases with pollen load. This is seen in the left pair of columns in Fig B: W did worse, if more D was added 2 days before, and vice versa in the right pair of columns.

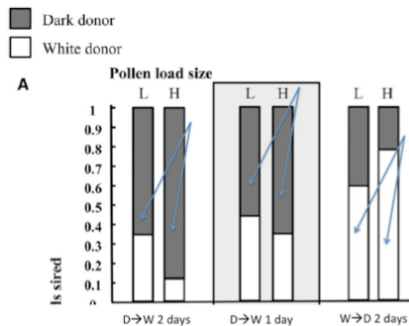

3. True

In fig. C, the first donor does worse if he is competing with more donors, even of his own kind (W or D).

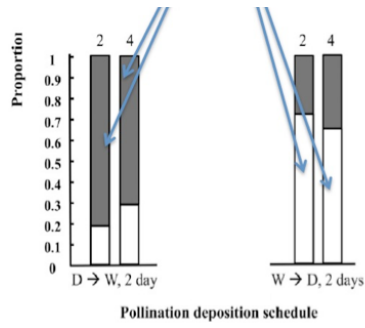

4. False

In Fig. B, there are still seeds sired by second donor after two days under high pollen load (10-15%).

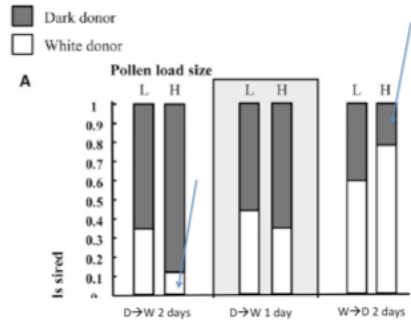

The relationship between light intensity and net photosynthesis rate (NPR) was measured in the submerged plant *Crassula helmsii* in a lake. The plant has CAM photosynthesis. Measurements of the photosynthetic rate ($\mu\text{mol O}_2 \text{ mg}^{-1} \text{ chlorophyll h}^{-1}$) were made on plants growing in shallow water (6.5 mg chlorophyll/g dry weight) and deep water (10.3 mg chlorophyll/g dry weight) in April and July (Fig.).

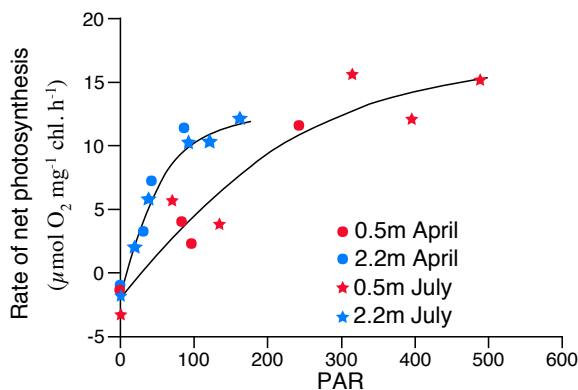

Light response curves in April and in July for *C. helmsii*, growing in shallow (0.5 m) and deep (2.2 m) water. PAR photosynthetically active radiation (from Klavnsen & Maberly 2009).

Indicate if each of the following statements is true or false.

TRUE FALSE

Shallow-water plants have higher NPR at 100 PAR than deep-water plants

TRUE FALSE

Deep-water plants have higher NPR in July than in April

TRUE FALSE

In the experiment, NPR is light limited

TRUE FALSE

Deep-water plants have a higher NPR because of their higher chlorophyll content

TRUE FALSE

Solution:

1. **False**

Plants, growing in shallow water, have a lower rate of net primary production ($4 \mu\text{mol O}_2 \text{ mg}^{-1} \text{ Chl h}^{-1}$) at $100 \mu\text{mol photon m}^{-2} \text{ s}^{-1}$ than plants growing in deep water ($10 \mu\text{mol O}_2 \text{ mg}^{-1} \text{ Chl h}^{-1}$). The reason may be that the shallow plants suffer from C limitation from competition from other plants/phytoplankton, whereas deep water plants have access to more C from decomposition and respiration processes, which can be taken up at the low light conditions, because the plant has CAM.

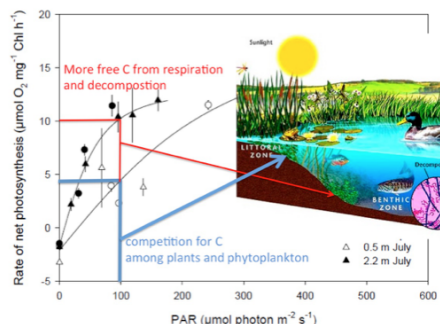

2. **False**

The graph shows no significant difference in the rate of net photosynthesis in July and April for deep-water plants. Light conditions stay the same.

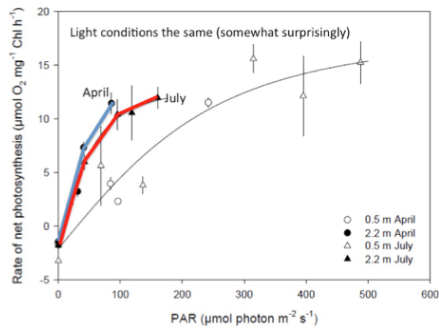

3. **True**

This can be seen from the figure. July plants do not have a significantly higher NPR than April plants (see error bars).

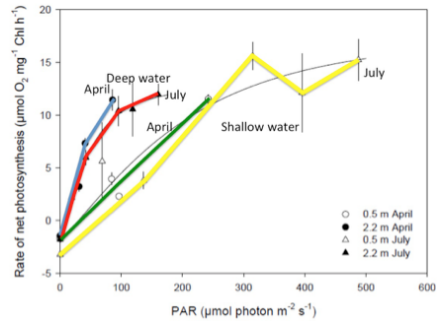

4. **False**

The difference in the figure between photosynthetic rate (NPR) for deep water and shallow plants is calculated per mg chlorophyll per dry weight, and thus is already corrected for the difference in cell content in chlorophyll (intro text). The difference in NPR can be explained by the CAM photosynthesis of the species, which at deep water can take advantage of the higher CO₂ concentrations here.

Q. 46

Some trees have large triangular, superficial lateral roots called buttresses (Fig. A). Their functions are widely discussed, but poorly understood. They are more common on trees with an asymmetrical crown; they may prevent windfall (Fig. B); presence of buttresses may also depend on soil type and inclination, and wood density. Their stabilizing importance was tested experimentally (Fig. C).

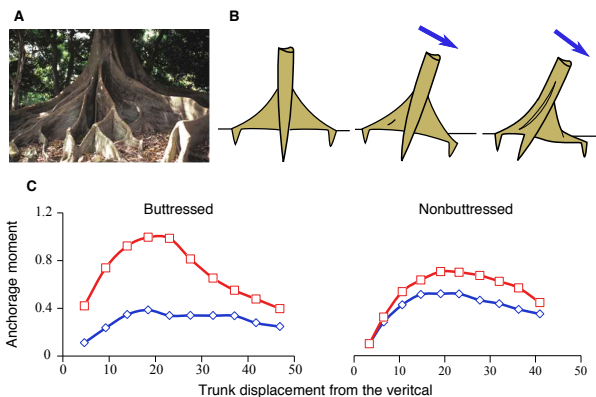

A, tree with buttress roots; B, a tree with buttresses and vertical tap root pulled over by wind (blue arrow is direction of wind); C, an experimental study of change in anchorage moment for butressed (left) and non-butressed trees (right) as a function of the tree's displacement from vertical (inclination in degrees); red squares are for trees with an intact root system, and blue diamonds for trees, in which all lateral roots (including buttresses, but excluding vertical tap root)) have been cut off (from Crook et al., 1991).

Indicate if each of the following statements is true or false.

TRUE FALSE

Buttresses of a tree help to increase the resistance of the tree to wind

TRUE FALSE

The tap root is relatively more important to anchorage in butressed than in non-butressed trees

TRUE FALSE

The smallest vessels and lowest vessel frequency are found in the parts of the tree, such as buttress roots, subjected to greatest mechanical stress

TRUE FALSE

Understorey trees growing below the canopy layer in a rainforest rarely have buttresses

TRUE FALSE

Solution:

1. True

Buttresses increase the anchorage moment of a tree and thus its resistance against wind (Fig. C). The strength or anchorage moment is defined as force X arm length (i.e. buttress length).

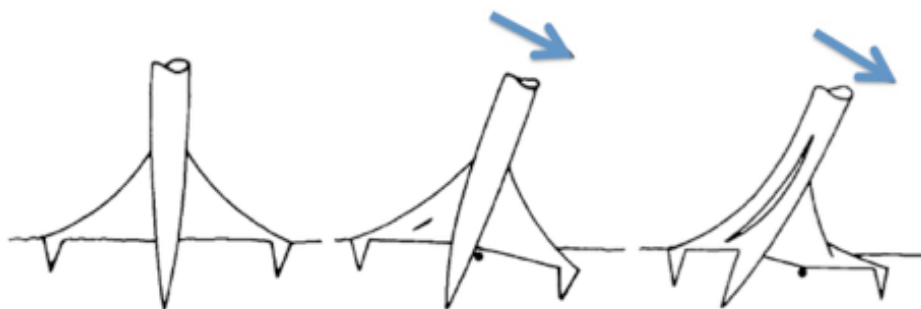

2. False

According to Fig. C, the max. anchorage strength of the cut butressed trees was only an average of 32% of intact trees; in contrast, cut non-butressed trees had 75% of the anchorage strength of intact trees. These results suggest that tap roots make a far more important contribution to anchorage in the non-butressed than the butressed trees.

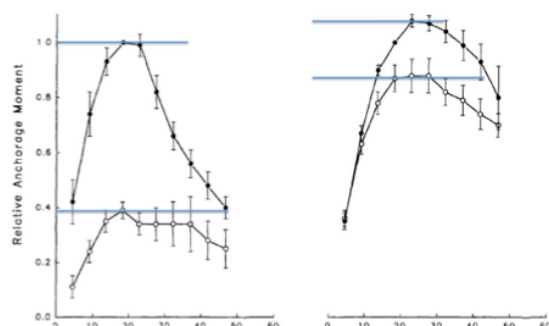

3. **True**

The crown grows towards the light, which moves the centre of gravity of the crown towards the light gap, causing a tension in the side of the trunk facing away from gap, selecting for buttresses on this side to counteract increased tension due to gravity.

4. **True**

The argument is that, there is no selection for wind protection in small trees living in a calm habitat (the understory).

Q. 47

Countries around the Baltic Sea have agreed to reduce the outlet of nutrients in drainage water, especially N. In a study, growth of diatoms, N-fixing cyanobacteria and dinoflagellates was monitored together with the seawater N: P ratio to estimate the effects of outlet reduction. Optimum N: P ratio for growth in the three groups is approximately 7.

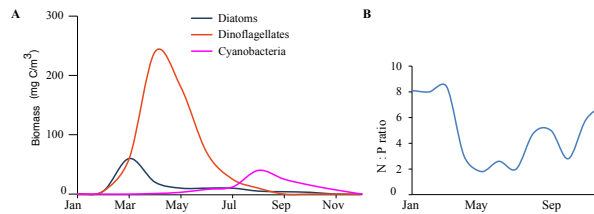

Annual variation in biomass of the three study groups (A) and seawater N: P-ratio (B) (from FF 1998).

Indicate if each of the following statements is true or false.

TRUE FALSE

The limiting factor for diatoms during the winter (January–March) is N

 TRUE FALSE

The limiting factor for phytoplankton during the summer (June–Aug.) is P

 TRUE FALSE

Less N from drainage water will, in particular, reduce growth of cyanobacteria

 TRUE FALSE

Autotrophic dinoflagellates begin to increase dramatically in number in early spring (March), because of their mobility

 TRUE FALSE

Solution:

1. False

With an N:P >8, N is not limiting.

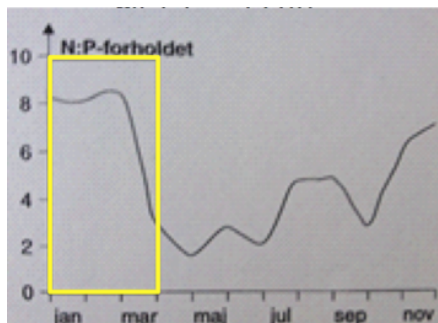

2. False

With an N: P ratio at about 2 for these months, there are relatively high levels of P, whereas N will be the limiting factor.

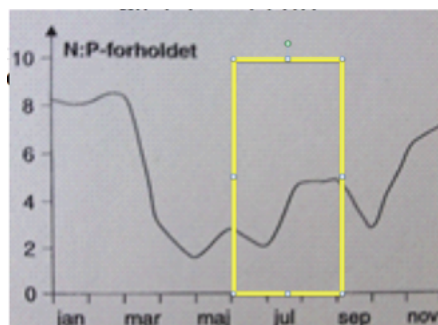

3. False

The cyanobacteria are more independent of access to nitrate because they are able to fixate atmospheric N₂ (mentioned in the introduction).

4. True

At this time of the year, there are plenty of nutrients and dinoflagellates with their two flagellae can move up towards the light (light might be limiting in early spring) (Partial knowledge).

Some plants deceive their pollinators by emitting odours, mimicking rotten flesh or dung. Such plants are pollinated by carrion and dung flies. This phenomenon is common among orchids, e.g. *Bulbophyllum variegatum*, three populations (ML, BB and ED) of which were studied at three different locations on the island of Réunion (Fig.).

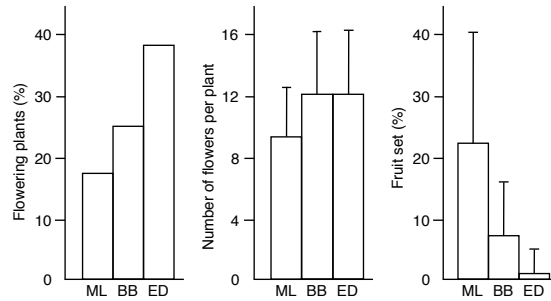

Reproductive data from populations ML, BB and ED (from Humeau et al. 2011).

Indicate if each of the following statements is true or false.

TRUE FALSE

Number of fruits produced per plant is higher in BB than in ML and ED

TRUE FALSE

Compared to ML and BB, fruit set in ED may have severe pollinator limitation

TRUE FALSE

Compared to ED and BB, ML may be a neighbour to cattle pastures

TRUE FALSE

Compared to ED and BB, ML may be a relatively young population

TRUE FALSE

Solution:

1. False

Figures of the first three left data columns are multiplied in order to get the fourth column (No. fruits/plant). ML has the highest reproductive output.

	No. flowering plants/plant (Fig. A)	No. flowers/flowering plant (Fig. B)	No. fruits/flower (Fig. C)	No. fruits/plant
ML	0.17	9	0.22	0.34
BB	0.25	12	0.07	0.21
ED	0.38	12	0.01	0.05

2. True

ED has the highest percent of flowering plants but the worst fruit set (fruits/flower), which most likely is caused by poor pollinator conditions (pollination/pollinator limitation).

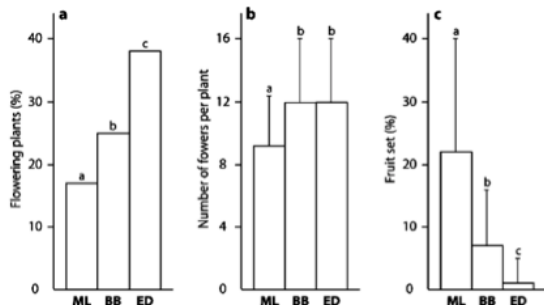

3. True

ML has the highest fruit set but the lowest proportion of flowering plants, which suggests the presence of many pollinators, which are flies laying their eggs in, for example, dung, and these flies could be recruited from a nearby pasture with cattle.

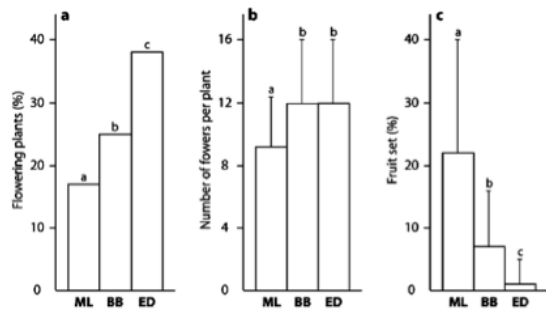

4. True

Very likely, since ML has the largest proportion of non-flowering individuals, which might be juveniles.

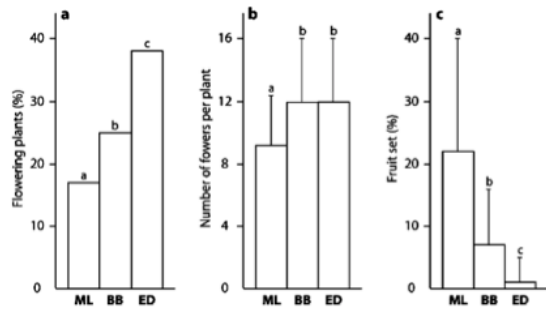

Plants interact with animals, and within a habitat, entire plant and animal communities form complex interaction networks. One important class of plant-animal networks is between fruit-eating birds and plants with fleshy fruit (Fig.). Observed interactions are partly determined by plant traits, but many other factors may be in play, e.g. the phylogenetic history of species communities.

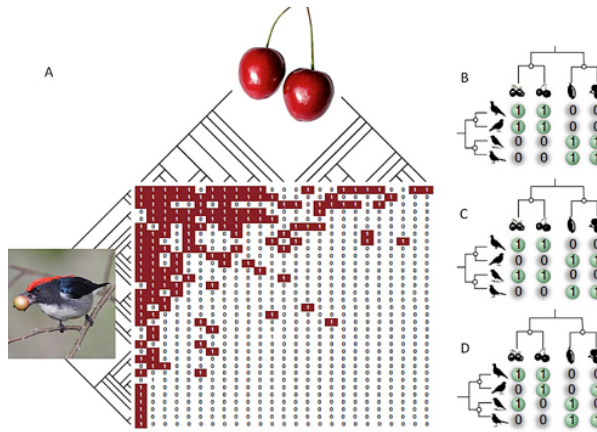

A, interaction matrix between fruit-eating bird species (rows) and fleshy-fruited plant species (columns). Each '1' is an observed interaction, and each '0' is no interaction. The phylogenies of the communities of birds and plants are included; B-D, small artificial networks showing various interaction pattern (from Jordano 2010).

Indicate if any of the following statements is true or false.

TRUE FALSE

The bird community has many food generalists, but only few specialists

TRUE FALSE

The plant community has many fruit consumer specialists, but only few generalists

TRUE FALSE

Phylogenetic relatedness is an important driver of interactions in network B

TRUE FALSE

Closely related birds reduce food overlap more in network C than in network D

TRUE FALSE

Solution:

1. **False**

The black frame shows the most generalized birds (many interactions) and outside we have the specialists with few links. Thus there are few generalists and many specialists.

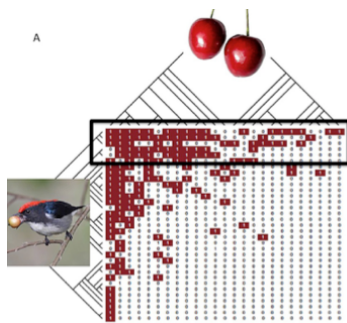

2. **True**

The black frame shows the most generalized plants (many interactions) and outside we have the specialists with few links. Thus there are few generalists and many specialists.

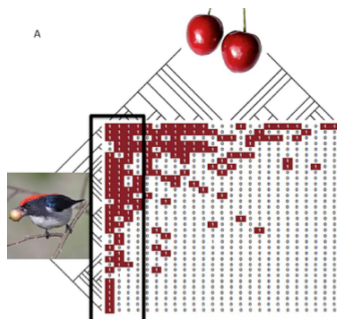

3. **True**

The two uppermost birds in the phylogeny are closely related and so are the two lowermost. The same for the plants: the two to the left and the two to the right constitute two pairs of closely related plant species. Thus closely related species have the same interactions and relatedness plays an important role to the shaping of the interaction pattern.

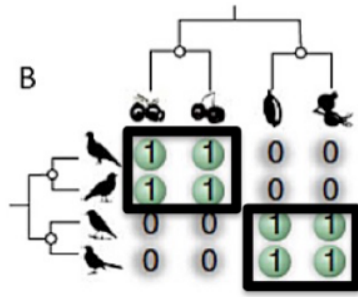

4. True

IN C, closely related plants share dispersers, but closely related birds do not overlap. In D, there is a partly overlap. Thus in C, diet overlap is smaller than in D.

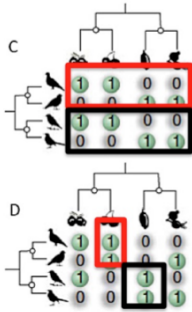

END