

INTERNATIONAL
BIOLOGY
OLYMPIAD e. V.

IBO



All IBO examination questions are published under the following Creative Commons license:



CC BY-NC-SA (Attribution-NonCommercial-ShareAlike) -
<https://creativecommons.org/licenses/by-nc-sa/4.0/>

The exam papers can be used freely for educational purposes as long as IBO is credited and new creations are licensed under identical terms. No commercial use is allowed.

THEORETICAL EXAM 1

OVERVIEW

This exam lasts three hours

- Q 1-13 Animal biology
- Q 14-15 Biosystematics
- Q 16-24 Cell biology
- Q 25-30 Ecology
- Q 31-33 Ethology
- Q 34-43 Genetics & Evolution
- Q 44-50 Plant biology

Each correctly answered question gives you 1 point, i.e. all four statements are correct.
If only three statements in a question are correct, you get 0.6 points
If only two statements in a question are correct you get 0.2
If only one statement in a question is correct you get 0.0
If no statements in a question is correct, you do not get any points.

 | Q. 1

In mammals, a high blood pressure is needed to achieve a high blood flow (cardiac fluid flow) and to overcome any vascular resistance against the flow of blood. In order to make deductions about blood flow, Poiseuille's Law is used (Fig.).

Poiseuille's Law: Q = fluid flow, V = volume, t = time, p = pressure, r = vessel radius, η = viscosity (constant for a given temperature and fluid type), L = vessel length, and R = flow resistance.

Indicate if each of the following statements is true or false.

TRUE FALSE

Assuming similar blood flow in a wide and a narrow artery of the same length, the change in mean blood pressure is greater in the former

Increased atherosclerosis leads generally to faster blood flow in the circulation

Comparing monozygotic twins, one living at sea level and the other at 3,000 m, the latter will have a higher resistance to blood flow

In a specific patient suffering from atherosclerosis, the radius of blood vessels on average had decreased by 1/6, which caused blood pressure to double to maintain the blood flow

Solution:

1. **False**

Assuming similar blood flow in a wide and a narrow artery, change in mean blood pressure per length is greater in the former
If statement is true, then:

$$\begin{aligned} Dp(\text{wide vessel}) &> Dp(\text{narrow vessel}) \\ Q \ 8 \ h \ L/[p \ r^4(\text{wide})] &> Q \ 8 \ h \ L/[p \ r^4(\text{narrow})] \\ 1/r^4(\text{wide}) &> 1/r^4(\text{narrow}) \\ r^4(\text{wide}) &< r^4(\text{narrow}) \end{aligned}$$

which is false.

– or just intuitively: The drop in pressure is larger in narrow than wide vessels.

$$Q = \frac{\Delta V}{\Delta t} = \frac{\Delta p \pi r^4}{8 \eta L}$$

$$\Delta p = R \Delta V$$

2. **False**

Increased arteriosclerosis leads to faster blood flow

Arteriosclerosis reduces the radius and thus also, according to Poiseuille's law, reduces Q, the blood flow.

$$Q = Dp \ p \ r^4(\text{wide})/8 \ h \ L$$

– or just intuitively: more narrow vessels means slower flow.

$$Q = \frac{\Delta V}{\Delta t} = \frac{\Delta p \pi r^4}{8 \eta L}$$

$$\Delta p = R \Delta V$$

3. True

Comparing monozygotic twins, one living at sea level and the other at 3,000 m, the latter will have a higher resistance to blood flow. If one lives at higher altitude, she has a higher density of red blood cells (higher haematocrit-value), and thus a higher viscosity η :

$$\Delta p = R \Delta V,$$

$$Q = \Delta p \pi r^4 / (8 \eta L)$$

$$Q = R \Delta V \pi r^4 / (8 \eta L)$$

$$R = Q 8 \eta L / (\Delta V \pi r^4)$$

Thus higher viscosity (η), means a higher blood flow resistance (R).

– or just intuitively: resistance increases, if blood gets more viscous.

$$Q = \frac{\Delta V}{\Delta t} = \frac{\Delta p \pi r^4}{8 \eta L}$$

$$\Delta p = R \Delta V$$

4. True

In a specific patient suffering from arteriosclerosis, radius of blood vessels on average had decreased by 1/6, which caused blood pressure to double

$$Q(\text{before vessel radius decreased}) = Q(\text{after vessel radius decreased})$$

$$\Delta p(\text{before}) \pi r^4(\text{before}) / (8 \eta L) = \Delta p(\text{after}) \pi r^4(\text{after}) / (8 \eta L)$$

$$\Delta p(\text{before}) r^4(\text{before}) = \Delta p(\text{after}) r^4(\text{after})$$

$$\Delta p(\text{before}) r^4(\text{before}) = \Delta p(\text{after}) (5/6 r)^4(\text{before})$$

$$\Delta p(\text{before}) = \Delta p(\text{after}) (5/6 r)^4$$

$$\Delta p(\text{after}) / \Delta p(\text{before}) = r^4(\text{before}) / (5/6 r)^4(\text{before})$$

$$\Delta p(\text{after}) / \Delta p(\text{before}) = (6/5)^4$$

$$\Delta p(\text{after}) / \Delta p(\text{before}) = 2.07$$

Reference

Campbell et al. 2015. 10th ed. P. 1010.

Q. 2

O₂-binding or -affinity to hemoglobin is affected by specific anions, in particular 2,3 bisphosphoglycerate (BPG) and chloride (Cl⁻), which are present in red blood cells and bind to the hemoglobin molecule at specific sites (Fig.).

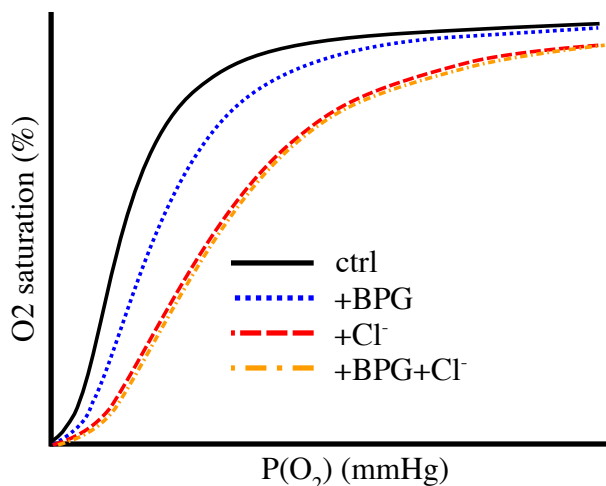

Hemoglobin saturation curves for hemoglobin without anions (ctrl) and with BPG, chloride or both, as a function of the partial pressure of oxygen in the blood.

Indicate if each of the following statements is true or false.

TRUE FALSE

If peripheral tissue lacks oxygen, red blood cells produce more BPG

At high altitudes, mutations leading to changes from polar to non-polar amino acid residues in the BPG binding site of the hemoglobin molecule will be favourable for the affinity of O₂ to hemoglobin in the lungs

It is likely that chloride and BPG bind at different sites in the hemoglobin molecule

BPG decreases the total oxygen saturation capacity of the hemoglobin

Solution:

1. **True**

DPG is produced in red blood cells during glycolysis and production increases, if oxygen concentration diminishes in peripheral tissue. Thus the dissociation curve moves to the right, causing an increased release of oxygen from the blood, and consequently counteracting the lack of oxygen in the peripheral tissue.

2. **True**

If mutations happen, the hemoglobin binds the polar DPG (it is an anion, see intro text and legend) less strongly (reducing its effect) and the O₂ saturation curve will become more similar to the control curve, which shows a higher O₂ affinity. This is adaptive (favorable), since at high altitudes the ambient PO₂ is lower and consequently, an O₂ saturation curve closer to the control means more oxygen in blood when it leaves the lungs.

3. **False**

With chloride present, DPG has no effect on the O₂ saturation curve, so chloride must occupy – at least in part – the binding site for DPG.

4. **False**

They decrease the affinity, not the oxygen carrying capacity. All curves reach approximately the same level of saturation (the right part of the curves).

Reference

Pomponi, M. et al. 2004. Hemoglobin, pH and DPG/chloride shifting. *Biochimie* 86: 927-932.
Campbell et al. 2015. 10ed. p. 1028.

Q. 3

In humans, lesions in the central visual pathways may have different consequences to the visual field (Fig.).

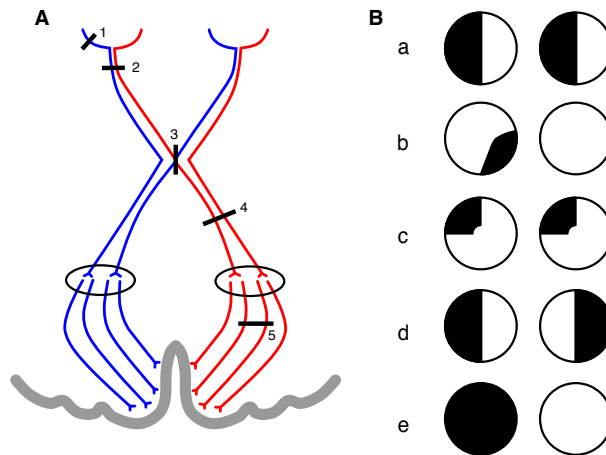

A, lesions (1–5) in the central visual pathways (seen from above); B, visual field deficits (a–e, deficits shown in black, as seen by the affected person) caused by lesions in A.

Indicate if each of the following statements is true or false.

	TRUE	FALSE
Lesion 2 corresponds to visual field deficit a	<input type="radio"/>	<input type="radio"/>
Lesion 3 corresponds to visual field deficit d	<input type="radio"/>	<input type="radio"/>
Lesion 4 corresponds to visual field deficit e	<input type="radio"/>	<input type="radio"/>
Lesion 5 corresponds to visual field deficit c	<input type="radio"/>	<input type="radio"/>

Solution:

1. **False**

Lesion before the chiasm causes loss of vision limited to the damaged eye, i.e. lesion 2 results in E (total loss of vision of the left eye).

2. **True**

If the optic chiasm is split down the middle, only the crossing fibers will be damaged and thus peripheral/lateral vision from both eyes will be lost.

3. **False**

If the right optic tract is cut, the left part of the visual field from both eyes will be lost as shown in A.

4. **True**

Lesions to part of the right visual cortex will only lead to loss of visual field from the left side of both eyes. As the optic radiation is more spread out, lesions often only occur to some of the fibers as shown here.

Reference

Cecere, R. 2013. Residual visual processing following real or virtual lesions to primary visual pathways. PhD. (many other refs).
Campbell et al. 2015. 10th ed. P. 1183.

Q. 4

The 2014 Nobel Prize winners in medicine demonstrated that, the hippocampal (HC) region in the human brain stores spatial memory and facilitates spatial orientation. People using space extensively such as taxi drivers may depend on a well-developed HC. A study focused upon differences in HC between London taxi drivers and a control group, and its results are shown in Figs A-B.

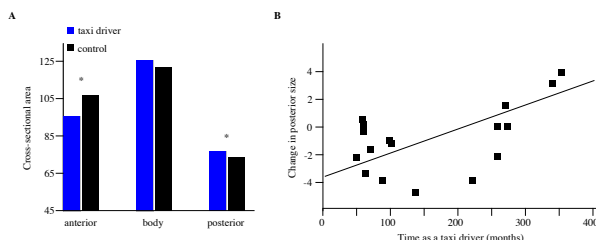

A, variation between taxi drivers and others in size of the entire hippocampus (HC, body) and its anterior and posterior parts separately (*, significantly different); B, correlation between volume change (grey matter) of posterior part of HC and employment time as taxi driver (from Maguire et al. 2000).

Indicate if each of the following statements is true or false.

Taxi drivers have significantly larger hippocampus than the control group

Spatial navigation may be located in the posterior part of hippocampus

The study provides evidence that some people are predisposed genetically to become better London taxi drivers than others in the population

The study supports the traditional view that the hippocampus is only involved in short-term memory

TRUE FALSE

Solution:

1. False

There is no significant difference in hippocampus body size (central pair of columns in Fig. A).

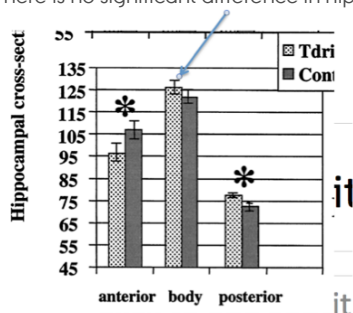

2. True

Conclusion from Fig. A (right pair of columns are significantly different) – if size of HC part is indicative.

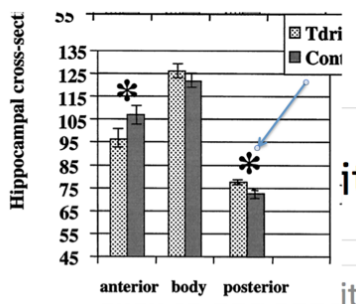

3. True

In the paper, Frith et al. (2015) discard genetics. However, the figure shows much variation during the first 50-100 months in volume of the posterior HC part – even a reduction in volume. The conclusion of the paper (Fig. B) is an increase with experience, but the relationship seems to be caused by just two taxi drivers.

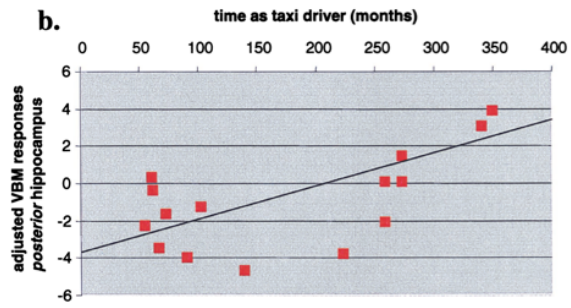

4. False

Fig. B shows that the increase in volume of the posterior part of HC is a long-term phenomenon. The traditional view is described in Campbell et al. (2015), p. 1162. Thus the results of Frith et al. contradict this.

Reference

Maguire, E. A., Gadian, D. G., Johnsrude, I. S., Good, C. D., Ashburner, J., Frackowiak, R. S. J. & Frith, C. D. 2000. Navigation-related structural change in the hippocampi of taxi drivers. *PNAS* 97: 4398-4403.

Campbell et al. 2015. 10ed. p. 1162.

Q. 5

In a study on kidney function, several parameters were measured in three healthy persons A–C (Table).

Parameter values describing kidney functions. Assume that 1 millimol O₂ has a volume of 22.4 ml (milli-litre).

	Person A	Person B	Person C
Glomerular filtration rate (GFR), ml/min	135	140	135
Renal blood flow (RBF), ml/min	1190	1240	1210
Urine production, ml/min	1.0	1.1	0.9
O ₂ concentration in arterial blood, ml/L	200	200	199
O ₂ concentration in venous blood from the kidneys, ml/L	184	186	184
Na ⁺ concentration in plasma, mmol/L	137	136	139
Na ⁺ concentration in urine, mmol/L	121	120	119

Indicate if each of the following statements is true or false.

	TRUE	FALSE
The amount of Na ⁺ filtrated in the kidneys is largest for person A	<input type="radio"/>	<input type="radio"/>
The amount of Na ⁺ excreted in the kidneys is largest for person B	<input type="radio"/>	<input type="radio"/>
Renal oxygen consumption is largest for person C	<input type="radio"/>	<input type="radio"/>
The amount of Na ⁺ reabsorbed per mol of O ₂ used is largest for person B	<input type="radio"/>	<input type="radio"/>

Solution:

1. **False**

Na⁺ is a ion and is filtrated completely. Filtration = GFR x [Na⁺ conc. in plasma]

B is correct

A: $135 \times 137/1000 = 18.5$ mmol Na⁺/min

B: $140 \times 136/1000 = 19.5$ mmol Na⁺/min

C: $135 \times 139/1000 = 18.8$ mmol Na⁺/min

Partial knowledge.

	Person A	Person B	Person C
Glomerular filtration rate (GFR), ml/min	135	140	135
Na⁺ concentration in plasma, mmol/L	137	136	139

2. **True**

Excretion = urine production x [Na⁺ conc. in urine].

B is correct

A: $1.0 \times 121/1000 = 0.12$ mmol Na⁺/min

B: $1.1 \times 120/1000 = 0.13$ mmol Na⁺/min

C: $0.9 \times 119/1000 = 0.11$ mmol Na⁺/min

Partial knowledge.

	Person A	Person B
Urine production, ml/min	1.0	1.1
Na ⁺ concentration in urine, mmol/L	121	120

3. False

Oxygen consumption = RBF x ([O₂ conc. in arterial blood] - [O₂ conc. in venous blood from kidneys])/1000.

A is correct

A: $1190 \times [(200 - 184)/1000] = 19.0 \text{ ml O}_2/\text{min}$

B: $1240 \times [(200 - 186)]/1000 = 17.4 \text{ ml O}_2/\text{min}$

C: $1210 \times [(199 - 184)]/1000 = 18.2 \text{ ml O}_2/\text{min}$

Partial knowledge.

	Person A	Person B	Person C
Renal blood flow (RBF), ml/min	1190	1240	1210
O ₂ concentration in arterial blood, ml/L	200	200	199
O ₂ concentration in venous blood from the kidneys, ml/L	184	186	184

4. False

Na⁺ absorbed per mol of oxygen = $\text{GFR} \times [\text{Na}^+ \text{ conc. in plasma} - \text{Na}^+ \text{ conc. in urine}] / [\text{RBF} \times (\text{O}_2 \text{ conc. in arterial blood} - \text{O}_2 \text{ conc. in venous blood from kidneys}) \times 1/22.4]$

C is correct

A: $135 (137 - 121) \times 22.4 / (1190 (200 - 184)) = 2.5 \text{ mol/mol O}_2$

B: $140 (136 - 120) \times 22.4 / (1240 (200 - 186)) = 2.9 \text{ mol/mol O}_2$

C: $135 (139 - 119) \times 22.4 / (1210 (199 - 184)) = 3.3 \text{ mol/mol O}_2$

Partial knowledge.

Reference

Campbell et al. 2015. 10ed. p. 1044-1047.

	Person A	Person B	Person C
Glomerular filtration rate (GFR), ml/min	135	140	135
Renal blood flow (RBF), ml/min	1190	1240	1210
O ₂ concentration in arterial blood, ml/L	200	200	199
O ₂ concentration in venous blood from the kidneys, ml/L	184	186	184
Na ⁺ concentration in plasma, mmol/L	137	136	139
Na ⁺ concentration in urine, mmol/L	121	120	119

Q. 6

The giraffe has the highest mean arterial blood pressure of any mammal. This renders it vulnerable to leg oedema. How the animal prevents this was studied with a focus on vascular adaptations in the leg (Fig.).

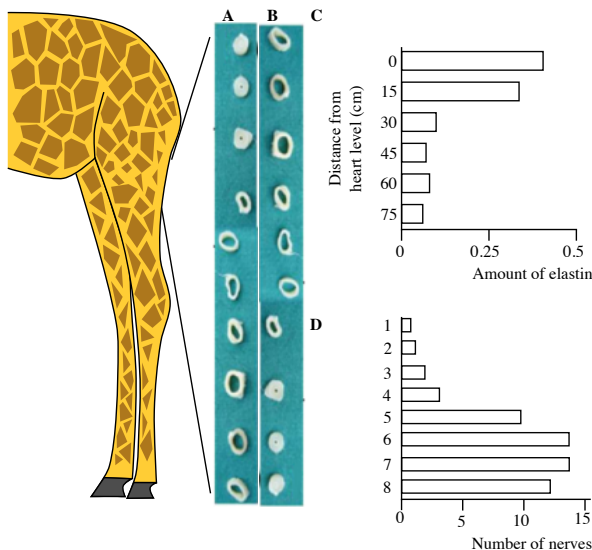

A-B, a series of cross-sections of leg arteries (a true and a false option); C, amount of elastin in arterial walls at increasing distance from the heart; D, number of nerves along arteries in the legs (bars 1-4: 15-30 cm from heart, bars 5-8: > 30 cm from heart) (from Petersen et al. 2013, Østergaard et al. 2011).

Indicate if each of the following statements is true or false.

Since arterial pressure at entrance to skull has to be similar to other mammals (c. 100 mm Hg), blood pressure down at the level of the hooves becomes very low

TRUE FALSE

The figures show how the diameter and wall thickness of arteries in the leg are expected to change; A is correct and B is wrong

Femoral arteries become more rigid distally toward the leg extremities

The giraffe has a special arterial mechanism above its knees to regulate blood pressure in the leg extremities

Solution:

1. **False**

Since arterial pressure at entrance to skull is similar to other mammals (c. 100 mm Hg), blood pressure down at the level of the hoofs becomes very low

Just because of gravity alone the pressure at hoofs increases to 350 mm Hg, much more than in any other animal. It is the sum of the hydrostatic pressure and the mean arterial pressure (Fig. not needed).

2. **False**

B is correct. Higher pressure towards hoofs requires thicker walls.

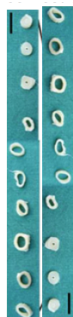

3. **True**

The amount of elastin in the arterial walls decreases (Fig. C) and this reduces the elasticity of the walls.

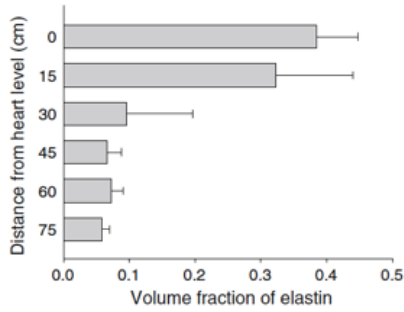

4. True

There is a sphincter-like structure at the knee: An abrupt narrowing of the lumen of the tibial artery just below the knee (Fig. B) and a decrease of elastin from above the narrowing to being almost absent below (Fig. C). In addition Fig. D shows that the sphincter area is highly innervated and thus seems to be under strong control (increased viscous resistance, i.e. less elastin (Fig. C) through sympathetic activation in order to reduce capillary pressure in legs).

Reference

Petersen et al. 2013. Protection against high intravascular pressure in giraffe legs. *Amer. J. Physiol. - Regul. Integr. Comp. Physiol.* 305: R1021-R1030.
 Østergaard et al. 2011. Pressure profile and morphology of the arteries along the giraffe limb. *J. Comp. Physiol. B.* 181: 691-698.

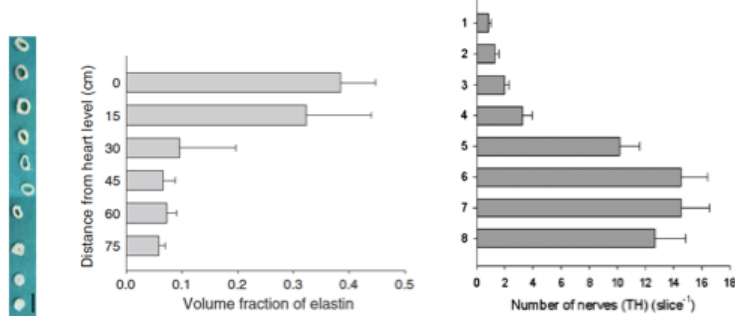

Q.7

Whales rely on sound for communication in a diverse way. In a study, vocalization measurements of two distantly related whales, Humpback and Bowhead, were compared to literature data from two other species (Fig.).

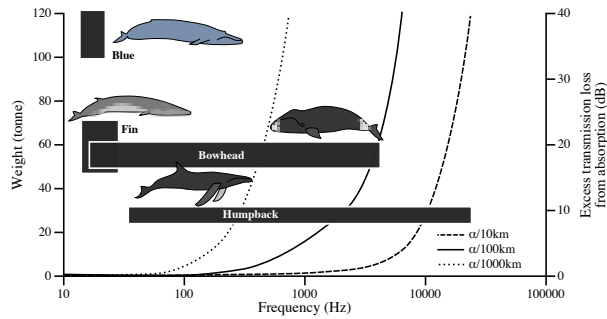

Frequency bands of vocalizations (horizontal bars) and range of body mass for 4 whale species together with the transmission loss from sound absorption in seawater at 10, 100 and 1000 km from source (from Tervo et al. 2012).

Indicate if each of the following statements is true or false.

TRUE FALSE

Larger whales are expected to produce lower frequency signals than smaller whales do

TRUE FALSE

Based on vocalizations, the Blue whale is expected to have more complex social behaviour than the Humpback.

TRUE FALSE

Humpback and Bowhead have a signalling frequency that makes it possible for them to have high inter-annual mating site-fidelity

TRUE FALSE

The similar vocalization patterns of Humpback and Bowhead whales are most likely due to convergent evolution

TRUE FALSE

Solution:

1. True

The transmission loss curve shows an increase in transmission loss with increasing sound frequency.

In general, larger animals have smaller population size and wider geographic range. Thus they must be able to communicate over larger distance and thus, according to the figure, produce low-frequency sounds because these sounds have the lowest transmission loss.

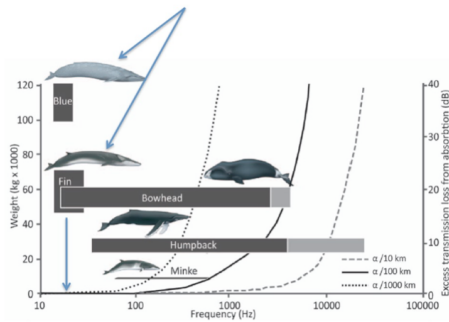

2. False

It is reasonable to assume that Humpback and Bowhead have a more complicated behaviour than Blue whale due to the large frequency variation in their song that allows for more information encodement. They produce both calls (< 500 Hz) and songs (> 1000 Hz).

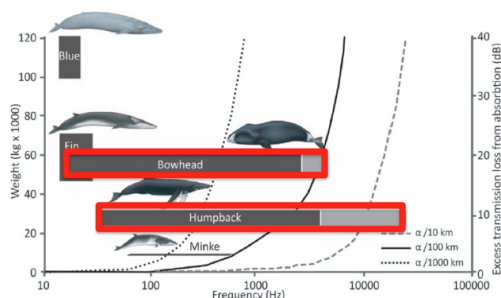

3. True

This is expected due to the short-range of their high-frequency songs (transmission loss curve), that means a reduced active space.

i.e. they need to be close together in order to communicate, thus site-fidelity is needed.

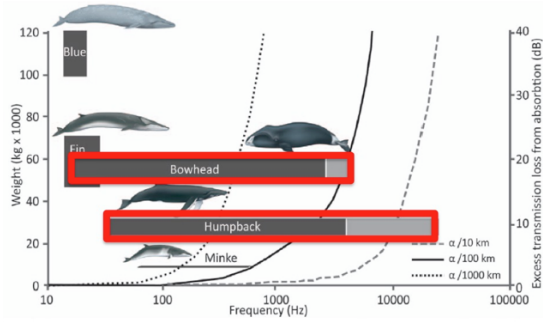

4. True

The two species are not closely related (as stated in the intro text); although they belong to the same family, Balaenopteridae. High frequency and complex song repertoire have coevolved with breeding aggregations.

Reference

Tervo, O. M., Christoffersen, M. F., Simon, M., Miller, L. A., Jensen, F. H., Parks, S. E. & Madsen, P. T. 2012. High source levels and small active space of high-pitched song in bowhead whales (*Balaena mysticetus*). *PLoS ONE* 7: e52072.

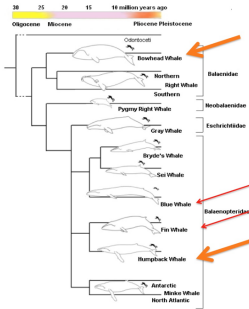

 | Q. 8

The coldwater Goldfish have a high tolerance to anoxia. They can degrade carbohydrates to lactate and further reduce lactate to ethanol. In a study running for 12 hours with two groups of goldfish, data on these processes were gathered (Table).

Concentration of lactate and ethanol in fish tissue, and compared with levels in the water of the aquarium, measured in terms of fish mass (kg) (from Shoubridge & Hochachka 1980).

	Fish tissue	Fish tissue	Water in aquarium	Water in aquarium
	Lactate mmol/kg	Ethanol mmol/kg	Lactate mmol/kg	Ethanol mmol/kg
Control: + O ₂	0.18	0.00	0.00	0.00
Treatment: no O ₂	5.81	4.58	0.00	6.63

Indicate if each of the following statements is true or false.

	TRUE	FALSE
During the study, lactate accumulation in fish tissue amounts to about half of the total ethanol produced	<input type="radio"/>	<input type="radio"/>
Goldfish are able to survive long periods under ice cover	<input type="radio"/>	<input type="radio"/>
Goldfish have no tolerance to ethanol	<input type="radio"/>	<input type="radio"/>
Transformation of lactate to ethanol may be a means of avoiding acidosis	<input type="radio"/>	<input type="radio"/>

Solution:

1. **True**

$5.81 / (4.58 + 6.63) = 0.52 \approx \text{half}$. That is after 12 hours ethanol is being produced from lactate, but the process is still running, and at the same time some of the ethanol has diffused out into the surrounding water.

	Fish tissue	Fish tissue	
	Lactate mmol/kg	Ethanol mmol/kg	L
Control: + O ₂	0.18	0.00	
Treatment: no O ₂	5.81	4.58	

2. **True**

Water under ice is low in oxygen. However, goldfish can survive anaerobically for a long period using glycolysis, i.e. the transformation of glucose to pyruvate and lactic acid. Lactic acid accumulation would reduce pH, but its conversion to ethanol, which diffuses out of the fish, solves this problem (Knowledge).

3. **False**

In contrast to lactic acid, ethanol can be excreted via the gills into the surrounding water, and the fish will thus not be intoxicated.

4. **True**

Lactate (CH₃CHOHCOOH) can be transformed to ethanol (CH₃CH₂OH) and COO⁻. The latter is a buffer. Fish blood has a poor hydrocarbonate buffer system, which is a consequence of the high solubility of CO₂ in water. Thus it is important to the fish, that lactic acid concentration should not reach too high levels. Ethanol can easily diffuse out into the surrounding water. **Thus the fish produces a buffer and at the same time is able to get rid of the ethanol** (Table) (Knowledge)

Reference

Shoubridge, E. A. & Hochachka, P. W. 1980. Ethanol: novel end product of vertebrate anaerobic metabolism. *Science* 209: 308-309.
Campbell et al. (2015). 10ed. Pp. 242-243, 253-.

Q. 9

Size-scaling metabolism is of general importance in biology, i.e. relating metabolic processes to body mass. In a study, the metabolic rate of the fish Japanese Flounder was measured during its early life stages (Fig.).

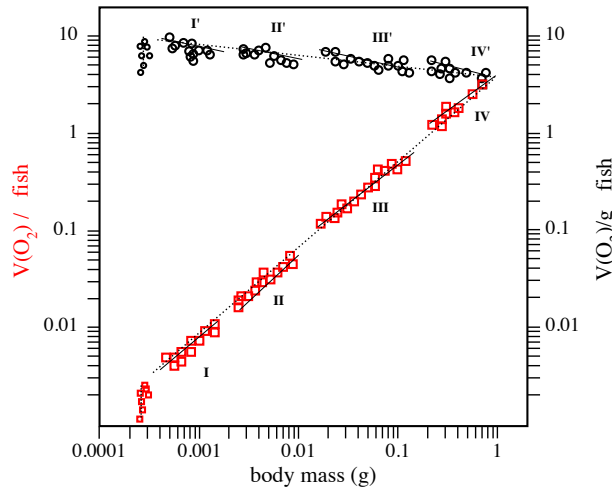

Ontogenetic changes in rate of respiration (V_{O_2} , squares, left Y-axis) and mass-specific rate of respiration (V_{O_2}/M , circles, right Y-axis) with increase in body mass M . Four early life stages (I-IV) from hatching were measured (from Yagi & Oikawa 2014).

Indicate if each of the following statements is true or false.

TRUE FALSE

Just after hatching, respiration increases without any increase in M

TRUE FALSE

For a given unit of body mass, the rate of respiration seems to increase with the age of fish

TRUE FALSE

The general equation for the lower curve in the figure is $V_{O_2}=aM^b$ (a : scaling parameter; b : scaling exponent)

TRUE FALSE

In the log-log plot there is a continuous linear increase in V_{O_2} over 4 orders of magnitude of body mass

TRUE FALSE

Solution:

1. True

The curve is a straight line in a log-log plot ($\log V_{O_2} = \log a + b \log M$) and thus a power function in a plot with arithmetic axes. That is the classic way of representing scaling with body mass.

2. False

The upper curve: Body mass increases with age and the upper curve shows that V_{O_2}/M decreases slightly with body mass (M). In the lower curve the slope < 1 .

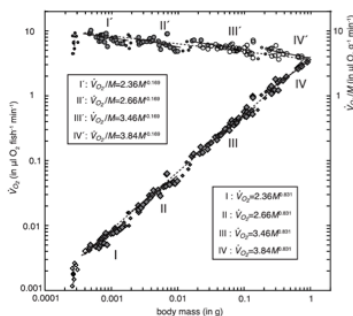

3. True

To the left in the figure, we see a short vertical line (of mostly unfilled diamonds), showing that this is the case. The reason is partly unclear.

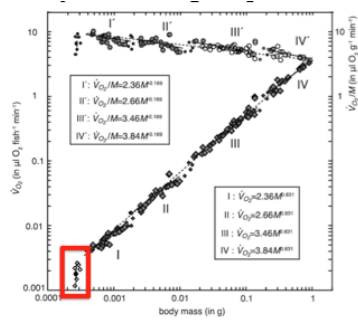

4. False

The study covers 3-4 orders of magnitude in M , but the figure also shows that there are four distinct ontogenetic stages, between which \dot{V}_{O_2} makes small jumps. This is related to changes in ecology (diet switches and swimming mode (between II and III the larva switches from vertical to horizontal swimming)) of the different stages. From the upper mass-specific line it is seen that each stage has its own slope (the scale exponent a).

Reference

Yagi, M. & Oikawa, S. 2014. Ontogenetic phase shifts in metabolism in a flounder *Paralichthys olivaceus*. *Scientific Reports* 4: 7135.
Campbell et al. 2015. 10th ed. p. 951.

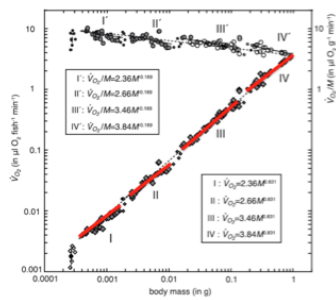

Q. 10

In a classic experiment (1935) by the Danish Nobel laureate H. Dam, chickens that were fed a lipid-depleted diet developed hemorrhage and started bleeding within a couple of weeks, because their uptake of vitamin K was inhibited. The bleeding may be stopped by adding vitamin K to the food (Fig.).

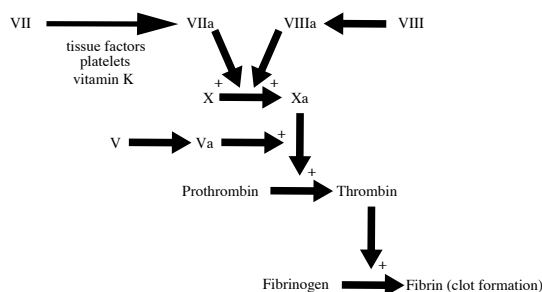

The blood coagulation cascade. Several of the pathways involved in coagulation are omitted for reasons of simplification. +, positive regulation; a, active form of compound.

Indicate if each of the following statements is true or false.

TRUE FALSE

A mutation called Factor V Leiden causes patients to produce a highly active form of factor V (Va in Fig.), therefore there is an increased risk of embolism

 TRUE FALSE

Bone-marrow insufficiency leads to increased coagulation

 TRUE FALSE

A lipid-rich diet may promote coagulation

 TRUE FALSE

People, suffering from a high risk of embolism, may be treated with heparin (antithrombin activator)

 TRUE FALSE

Solution:

1. **True**

Increased activity of factor V will lead to increased effect of Xa on the formation of thrombin from prothrombin, and more thrombin means more coagulation and embolism.

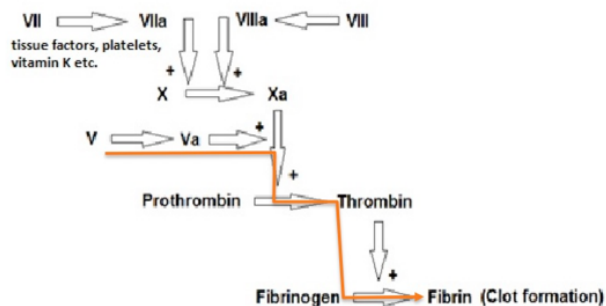

2. **False**

Bone marrow insufficiency leads to decreased formation of amongst other cells, platelets (Fig.), which will lead to a decrease in coagulation. (Knowledge).

3. **True**

A lipid-rich diet will lead to a higher level of blood cholesterol, which again will lead to an enhanced uptake of vitamin K (intro text), which then becomes available to the coagulation process (Fig.).

4. **True**

This can be answered from the figure (antithrombin/thrombin etc.). Heparin activates antithrombin, which deactivates thrombin, thus decreasing coagulation and the risk of emboli. An embolus may be a blood clot, fat globule, or gas bubble, in the bloodstream.

Reference

Lieberman et al. 2012. *Marks Basic Medical Biochemistry*, 3. Ed.
 Dam, H. 1934. The antihæmorrhagic vitamin of the chick. *Nature* 135: 652-653.
 Campbell et al. 2015. 10th Ed. P. 1015-1016.

Q. 11

Muscle fatigue during work results in increasing extracellular concentration of K^+ . This may be modified by changes in physiological temperature and lactic acid level, and can be treated medically with the drug salbutamol. This was studied experimentally with rat muscles stimulated electrically once every 20 minutes (Fig.).

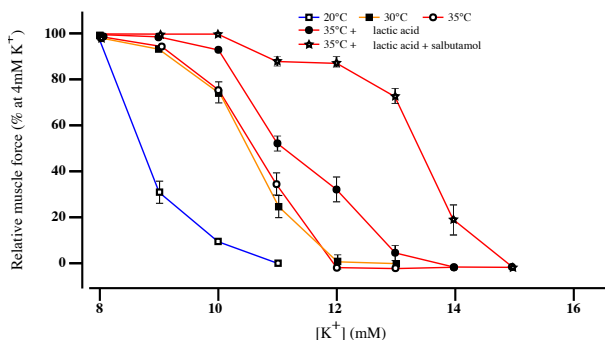

Effect of warm-up at 20°C, 30°C and 35°C before work or addition of lactic acid or a combination of lactic acid and salbutamol at 35°C on the change in muscle force (as percent of force at 4 mM [K⁺]) (from Pedersen et al. 2003).

Indicate if each of the following statements is true or false.

	TRUE	FALSE
During work, contracting muscles lose K^+ , leading to increased extracellular $[K^+]$	<input type="radio"/>	<input type="radio"/>
Temperature increase, and addition of lactic acid and drug operate mainly additively	<input type="radio"/>	<input type="radio"/>
The study design is incomplete	<input type="radio"/>	<input type="radio"/>
At physiological temperature (here 35°C), lactic acid protects completely against muscle fatigue	<input type="radio"/>	<input type="radio"/>

Solution:

- True**
This is seen from both Fig. A-B. The increase in $[K^+]$ is the extracellular plasma and interstitial concentration.
- True**
The effects of an increase in temperature, lactic acid addition and salbutamol addition vary with $[K^+]$.

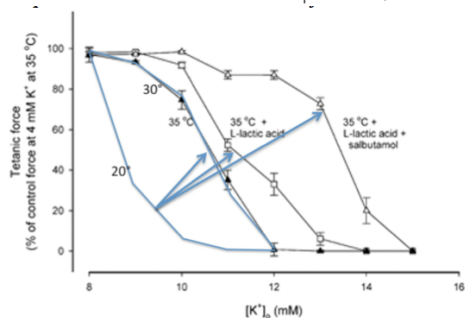

- True**
There is no pure salbutamol treatment, and in the temperature part the comparison is between 20 and 30°C and in the lactate/salbutamol part the experiment takes place at 35°C.
- False**
Physiological temperature is here 35°C, and it is seen from Fig. B that addition of lactic acid restores tetanic force, e.g. at $[K^+] = 12$ mM tetanic force recovers from c. 0% to c. 35%.

Reference

Pedersen, T. H., Clausen, T. & Nielsen, O. B. 2003. Loss of force induced by high extracellular $[K^+]$ in rat muscle: effect of temperature, lactic acid and β_2 -agonist. *Journal of Physiology* 551: 277-286.
Campbell et al. 2015. 10th ed. P. 255.

 | Q. 12

Four groups (A-D), each of 12 diabetic rats, received different diets for four weeks (Table). Researchers wanted to see if a traditional anti-diabetic plant (containing stevioside) had any effect.

Four diets (A-D) and measurements of parameters related to diet. BW, body weight. If figures are different, they are here assumed to be significantly so (from Jeppesen et al. 2006).

Concentration, blood pressure or body weight	Group A: Chow = Standard carbohydrate-rich diet	Group B: Chow + SVS (SVS = 0.03 stevioside g/(kg BW day))	Group C: 20% Chow + 80% SPI (SPI = Soy bean Protein Isolate)	Group D: 20% Chow + 80% SPI + SVS (SPI = Soy bean Protein Isolate + SVS = 0.03 stevioside g/(kg BW day))
Fasting blood glucose (mmol/L)	3.4	3.4	3.4	3.4
Plasma glucose (mmol/L) after 240 min	991	757	819	439
Plasma insulin (ng/mL) after 30 min	11	19	9	24
Plasma insulin (ng/mL) after 240 min	316	375	218	249
Plasma glucagon (pg/ml) after 240 min	21918	17024	26200	17529
Total cholesterol (mmol/L)	2.5	2.3	2.1	1.8
Systolic blood pressure at start (mm Hg)	175	171	165	170
Systolic blood pressure after 4 weeks (mm Hg)	178	148	173	155
BW (g)	226	221	222	204

Indicate if each of the following statements is true or false.

TRUE FALSE

A pure chow diet is not recommended for diabetic rats as it increases cholesterol level and blood pressure

 TRUE FALSE

SVS and SPI seem to have a synergetic effect

 TRUE FALSE

Stevioside is harmful to diabetics

 TRUE FALSE

When fasting, blood glucose results show that there is no statistical difference between the four groups of rats

 TRUE FALSE

Solution:

1. **True**

Total cholesterol: (mmol/L): group A) 2.5 is highest.

Blood pressure after four weeks: group A) 178 mm Hg is highest.

Concentration, blood pressure or body weight	Group A Chow = Standard carbohydrate-rich diet	Group B Chow + SVS (SVS = 0.03 stevioside g/(kg BW day))	Group C 20% Chow + 80% SPI (SPI = Soy bean Protein Isolate)	Group D 20% Chow + 80% SPI + SVS
Total cholesterol (mmol/L)	2.5	2.3	2.1	1.8
Systolic blood pressure after 4 weeks (mm Hg)	178	148	173	155

2. True

True, because group D has:

- a much reduced plasma glucose level compared to groups B-C,
- an almost doubled insulin production immediately after intake,
- a decrease in total cholesterol, and to some extent also
- a decrease in systolic blood pressure.

Concentration, blood pressure or body weight	Group A Chow = Standard carbohydrate-rich diet	Group B Chow + SVS (SVS = 0.03 stevioside g/(kg BW day))	Group C 20% Chow + 80% SPI (SPI = Soy bean Protein Isolate)	Group D 20% Chow + 80% SPI + SVS
Plasma glucose (mmol/L): From 0-240 min	991	757	819	439
Plasma insulin (nanog/mL): From 0-30 min	11	19	9	24
Total cholesterol (mmol/L)	2.5	2.3	2.1	1.8
Systolic blood pressure after 4 weeks (mm Hg)	178	148	173	155

3. False

Stevioside alone, and together with soybean (groups B and D), lowers blood glucagon level, which is beneficial in the treatment of diabetics, and also increases insulin production.

Concentration, blood pressure or body weight	Group A Chow = Standard carbohydrate-rich diet	Group B Chow + SVS (SVS = 0.03 stevioside g/(kg BW day))	Group C 20% Chow + 80% SPI (SPI = Soy bean Protein Isolate)	Group D 20% Chow + 80% SPI + SVS
Plasma glucose (mmol/L): From 0-240 min	991	757	819	439
Plasma insulin (nanog/mL): From 0-30 min	11	19	9	24
Plasma insulin (g/mL): From 0-240 min	316	375	218	249
Plasma glucagon (picograms/ml): From 0-240 min	21918	17024	26200	17529

4. True

Values in first row of table are similar.

Reference

Jeppesen, P. B. et al. 2006. Can stevioside in combination with a soy-based dietary supplement be a new useful treatment in type 2 diabetes? An in vivo study in the diabetic Goto-Kakizaki rat. *Review of Diabetic Studies* 2006, s. 189-199.

Concentration, blood pressure or body weight	Group A Chow = Standard carbohydrate-rich diet	Group B Chow + SVS (SVS = 0.03 stevioside g/(kg BW day))	Group C 20% Chow + 80% SPI (SPI = Soy bean Protein Isolate)	Group D 20% Chow + 80% SPI + SVS
Fasting blood glucose (mmol/L)	3.4	3.3	3.4	3.4
BW (g)	226	221	222	204

Q. 13

Strategies for regulating body temperature include controlling the movement of blood between the body core and surface and by countercurrent heat exchangers (Fig.).

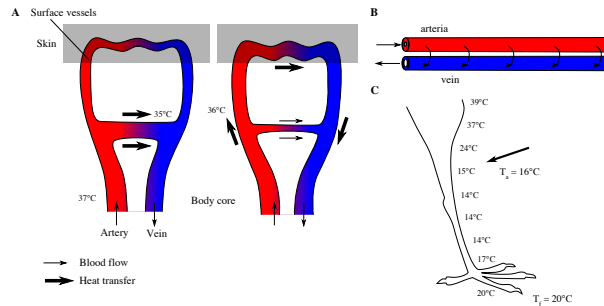

Figure. A. Regulation of heat conductance at body surface; B. thermal countercurrent system; C. body temperature in a bird limb. T_a = ambient temperature. T_f = floor temperature. (from Willmer et al. 2005).

Indicate if each of the following statements is true or false.

TRUE FALSE

In Fig. A, the shunt vessel to the left is exposed to a lower exterior temperature than the one to the right

TRUE FALSE

In Fig. B, a countercurrent system often seen in animals from warm habitats is shown

TRUE FALSE

The animal in Fig. C lives in a warm habitat

TRUE FALSE

In Fig. C, the venous blood at the arrow has a temperature between 14-15°C

TRUE FALSE

Solution:

1. True

The surface capillary (red arrow) is restricted and the arteriole to venule pathway (blue arrow, anastomose) is dilated.

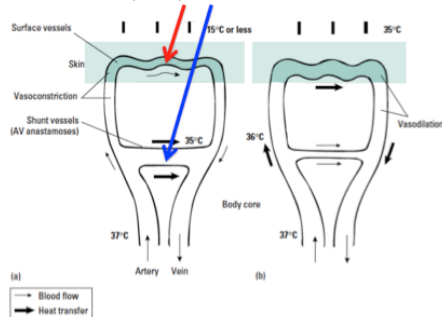

2. False

The system here saves heat, and thus the animal lives in a cold environment. Warm blood in the arterioles runs parallel and very close to the venous return, so that heat can be exchanged (conserved) and returned to the body, leaving the appendages cooler.

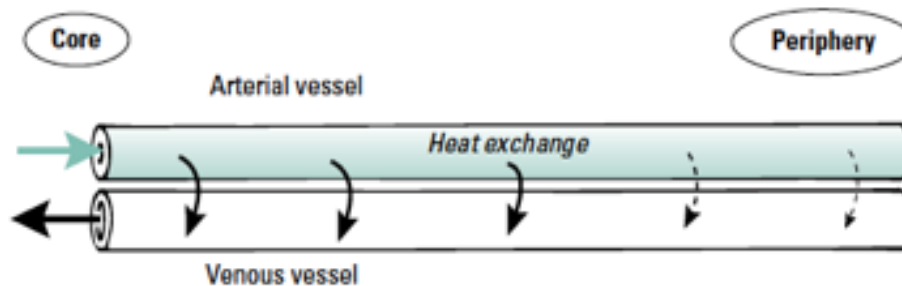

3. False

As in statement 2, this animal lives in a cold environment, the temperature gradient shows that a countercurrent heat exchange system is operating.

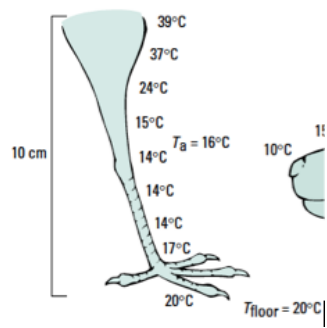
4. **True**

The body temperature at arrow is 15°C, thus the arterial blood must be slightly warmer (e.g. 16°) and the venous blood slightly cooler, i.e. the latter has a temperature below 15° but above the 14° (e.g. 14.5°), which is the next measuring point.

Reference

Willmer, P. et al. 2005. Environmental physiology of animals. 2nd ed.
Campbell et al. 2015. 10th ed. p. 946.

Q. 14

Among plant families, grasses and Chenopodiaceae contain many species using the C₄ photosynthesis pathway, and many C₄ species have evolved independently from C₃ ancestors within these families. The figures show cross-sections of C₃ and C₄ leaf types from different species.

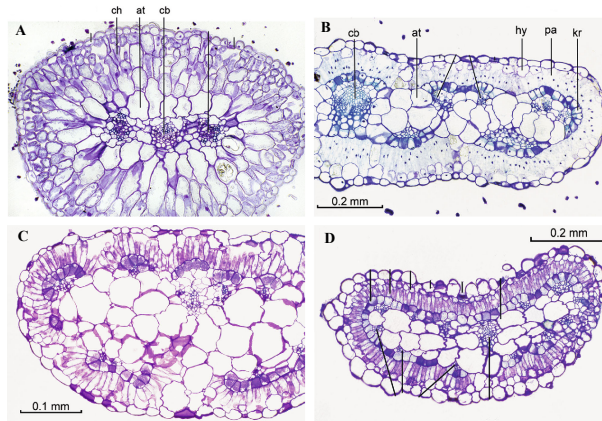

Cross section of leaves from: A. C₃ species; B. C₄ species; C-D. C₃ or C₄ species. ch = chlorenchyma; at = aqueous tissue; cb = central vascular bundle; hy = hypodermis; pa = palisade cells or mesophyll cells; kr = Kranz cells or bundle-sheath cells (from Freitag & Kadereit 2014).

Indicate if each of the following statements is true or false.

TRUE FALSE

Evolution of C₄ species is favoured in a climate of increasing drought, salinity and heat, but with no change in CO₂ level

 TRUE FALSE

Leaf in Fig. C is from a C₃ plant

 TRUE FALSE

Leaf in Fig. D is from a C₃ plant

 TRUE FALSE

During a period of global CO₂ increase, without a concomitant increase in temperature, the global distribution of C₄ plants is likely to expand

 TRUE FALSE

Solution:

1. **True**

"... C₄ photosynthesis minimizes photorespiration and enhances sugar production. This adaptation is especially advantageous in hot [and dry] regions with intense sunlight, where stomata partially close during the day, and it is in such environments that C₄ plants evolved and thrive today." Campbell p. 277-279 (Knowledge). At present levels of CO₂ there seems to be no major difference between the two kinds of photosynthesis.

2. **False**

The figure shows that there are Kranz cells, i.e. the picture is from a C₄ plant.

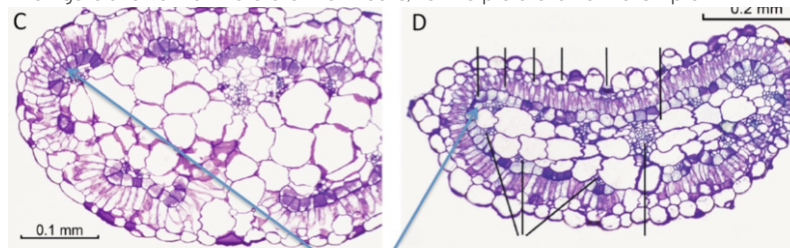

Kranz-cells

3. **False**

The figure shows that there are Kranz cells, i.e. the picture is from a C₄ plant.

4. **False**

Rising CO₂ levels decrease photorespiration and should therefore benefit C₃ plants. However, if temperature increases too, it may enhance photorespiration, that is why I write "might".

Genetic variation in three chloroplast DNA (cpDNA) regions was studied in populations of a rare orchid *Vexillabium yakushimense*. Material from nine populations on Honshu and two populations on the Japanese Nansei Islands (Yakushima and Okinawa) were sampled (Fig.).

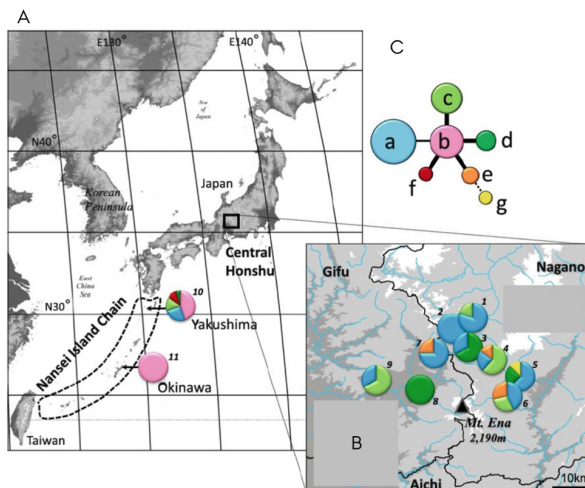

A–B, geographic distribution of 7 cpDNA haplotypes of *V. yakushimense*. Pies are populations, and each colour indicates a haplotype. The size of each coloured slice shows proportion of each haplotype in the population; C, parsimony network: circles a to g are seven different haplotypes in the 11 populations. Circle size indicates frequency of each haplotype. Linked haplotypes differ by only 1–2 mutations (from Saeki et al. 2014).

Indicate if each of the following statements is true or false.

The origin of the orchid in Japan might be mainland Honshu because of the high genetic diversity observed here

It is likely that a founder effect can be seen in Okinawa

CpDNA is better than nuclear DNA in revealing maternal origins of individuals

The study suggests that mountains and river basins are more effective barriers to gene flow than the sea separating islands

TRUE FALSE

<input type="radio"/>	<input type="radio"/>
<input type="radio"/>	<input type="radio"/>
<input type="radio"/>	<input type="radio"/>
<input type="radio"/>	<input type="radio"/>

Solution:

1. **False**

Figure C indicates that haplotype b is the oldest, because of its central position in the network.

Original text:

"[The] patterns suggest that haplotype H-b is of more ancient origin than the others. When the species migrated northward in the past, the other haplotypes may have become dominant via foundation effects and genetic drift." Saeki et al. 2014: 7.

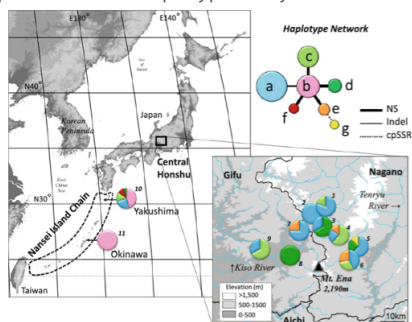

2. **True**

This is not stated in the paper, but it is likely, because only one haplotype is found here and it is a small island, and the population is probably also small and if more genetic variation was present at the time of colonization it might have disappeared by genetic drift.

3. **True**

Genetic variation is generally lower within than among species, and variation is more likely to be observed in the single stranded DNA in the chloroplast than in the nucleus (Knowledge).

4. **True**

The same haplotype (pink) is found on the islands, but in the complex landscape on Honshu we have a very high haplotype diversity.

Q. 16

Nitrous oxide (N₂O) is a greenhouse gas, produced by bacteria through either nitrification or denitrification (Fig. A). Many aquatic invertebrates (e.g. zebra mussel) emit N₂O, due to the activity of bacteria in their gut and the biofilm covering their shell (Fig. B, Table).

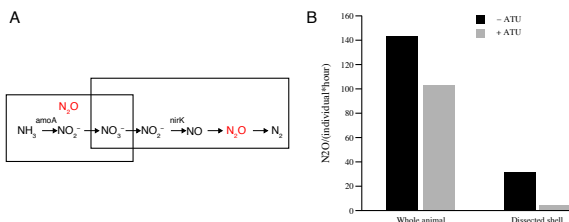

A, pathways for N₂O production in bacteria, with key genes *amoA* (encoding ammonia monoxygenase AMO, nitrification) and *nirK* (encoding nitrite reductase NIR, denitrification); B, N₂O emission from living zebra mussels and shells dissected from living animals, incubated with (+ATU) or without (-ATU) allylthiourea, which is a specific inhibitor of nitrification (from Svenningsen et al. 2012).

Expression sites of key genes for N₂O production in zebra mussels. *amoA* produces the enzyme AMO, which catalyses nitrification; *nirK* produces the enzyme NIR, which reduces nitrite.

Material	Expression of	Expression of
	<i>amoA</i> (cDNA copies/mg)	<i>nirK</i> (cDNA copies/mg)
Gut	-	205-1585
Shell biofilm	200-2000	-

Indicate if each of the following statements is true or false.

Most N₂O in zebra mussel is produced by bacteria inside the animal (e.g. in gut)

TRUE FALSE

The N₂O production from mussel shells is mostly due to nitrification in their biofilm

Nitrification and denitrification are equally important for N₂O emission from mussels

Increasing nitrate (NO₃⁻) concentrations in lakes (e.g. from agricultural run-off) will increase N₂O emissions from freshwater invertebrates

Solution:

1. True

According to the black bars of Fig. B, dissected shells contribute only c. 25% (=100 x c. 35/(c. 145)) to total N₂O emission from whole animals, hence the other 75% must come from inside the mussel (gut).

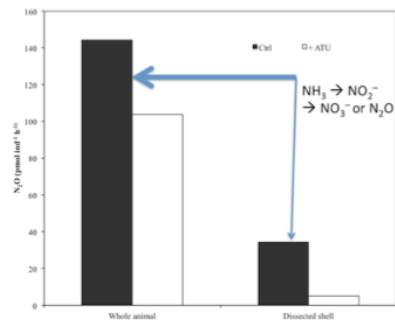

2. True

N₂O emission from shells is almost completely inhibited by ATU (comparison of black and white bars in 'Dissected shell', Fig. B), which specifically inhibits nitrification. Denitrification is not important in the shell, perhaps because there is access to plenty of oxygen in the thin biofilm of the shell. In addition, according to table, *nirK* is not expressed in the shell.

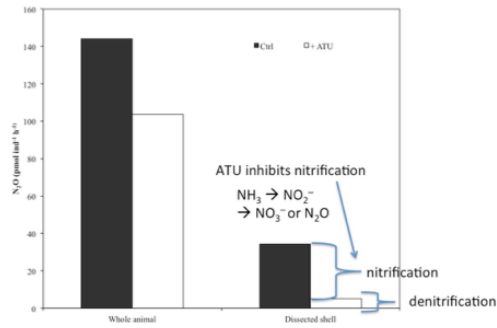

3. False

Expression site for nitrification is in the shell, and for denitrification the entire animal (Table), the N₂O measurements on whole animals show that inhibiting nitrification with ATU reduces N₂O emissions only by 25%; the remaining 75% must therefore be due to denitrification bacteria in the gut (comparison of black and white bars for 'whole animal').

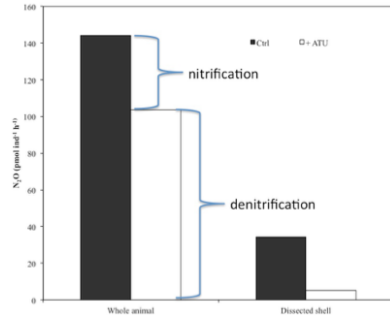

4. True

Nitrate is a precursor of N₂O in the denitrification pathway, which is the dominating process for N₂O emission in zebra mussels and other freshwater invertebrates. Hence increasing the precursor concentration (nitrate) will also increase the rate of product (N₂O) formation. Since N₂O is a gas, it will not accumulate, but freely be emitted to water and atmosphere.

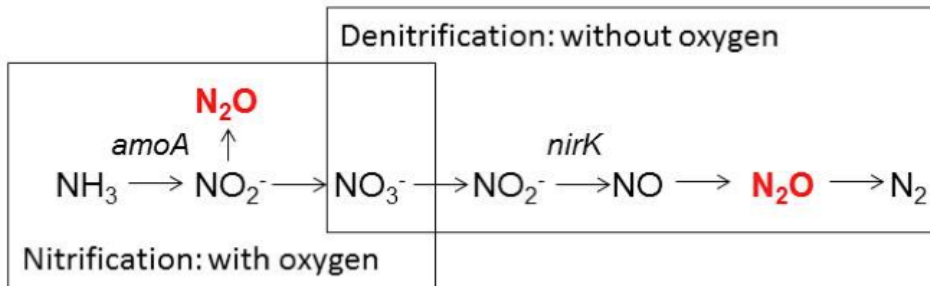

Q. 17

Filoviruses, e.g. Ebola (EBOV) and Marburg (MAR), cause haemorrhagic fever. Case fatality rates are >90%, and among the highest reported for any human pathogen. Vaccine or therapeutic products are not available. Recently, however, researchers tested an adenosine analogue, BCX, which seemed to improve survival of filovirus-infected humans (Fig.).

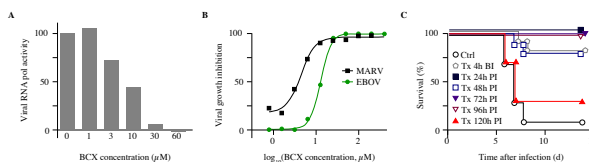

A. effect of BCX on viral RNA polymerase activity; B. inhibition of EBOV and MAR growth in infected stem cells treated with BCX; C. survival of infected mice after BCX treatments (Tx) administered up to 14 days, beginning either before infection (BI) or post-infection (PI) at varying delays (from Warren et al. 2014).

Indicate if each of the following statements is true or false.

TRUE FALSE

As an adenosine analogue, BCX affects viral gene transcription

TRUE FALSE

BCX is applicable exclusively against ebola

TRUE FALSE

BCX can successfully (>50% survival) be administered up to 10 days after Ebola infection

TRUE FALSE

The half-maximal inhibition of BCX is achieved at a concentration of about 10 µM

TRUE FALSE

Solution:

1. True

BCX-TP is an adenosine (in text), which is a generally occurring ribo-nucleoside, and as such it is expected to interfere with polymerase and it hampers transcription (Fig. A) and thus also viral coating (glycoprotein) (Fig. B).

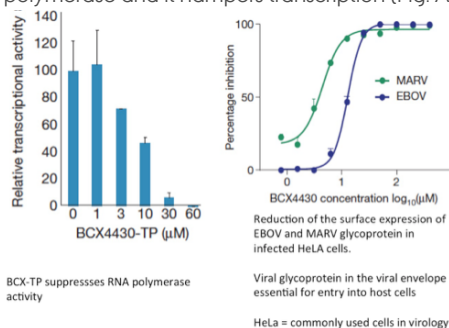

2. False

It is also effective against another filovirus – Marburg virus (Fig. B).

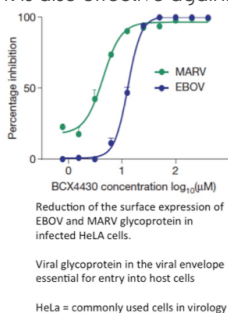

3. False

Ten days will be too late for a strong effect. In order to get a strong effect, BCX-TP has to be administered no later than 5-6 days after infection (Fig. C). If administered after 8 days, survival is only c. 30% (yellow triangles in Fig. C).

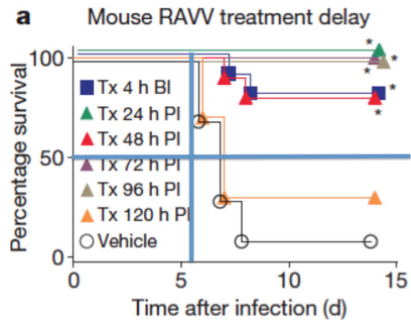

4. True

Fig. A and B: Above 10 microM BCX-TP, we get 50% reduction of activity. The same is seen Fig. B, where we see a 50% inhibition at a BCX-TP concentration of log 1 = 10 microM.

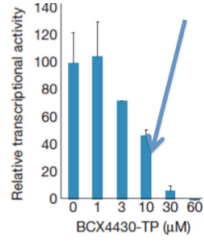

BCX-TP suppresses RNA polymerase activity

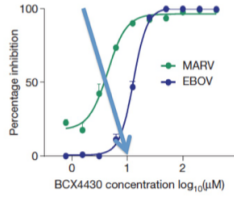

Reduction of the surface expression of EBOV and MARV glycoprotein in infected HeLa cells.

Viral glycoprotein in the viral envelope essential for entry into host cells

HeLa = commonly used cells in virology

Q. 18

Botanists may identify plants to family using diagrams, showing the different floral parts (Fig. A). According to the ABC gene model, development of a flower is based on expression of the A-, class-B- and C-genes. In dicots, sepals develop if gene-A is expressed alone, petals develop if both gene-A and gene-class-B are expressed, stamens develop if both gene-class-B and gene-C are expressed, and an ovary develops if only gene-C is expressed.



A, diagram of a monocot flower; B, tulip flower (a monocot), parts of the flower are removed in photo to the right; C, the ABC gene model of monocot flower development (I, ovary; II, stamens; III, petals; IV, sepals; the latter two are similar in most monocots). Gene-class-B consists of 3 genes B1-B3 (from Johansen et al. 2006).

Indicate if each of the following statements is true or false.

TRUE FALSE

Tulips do not have any sepals

 TRUE FALSE

Gene-C has different expression in monocots and dicots

 TRUE FALSE

Selective suppression of gene C-expression in region II leads to development of unisexual flower

 TRUE FALSE

Complete development of stamens in the tulip requires the expression of gene-B1+gene-B3+gene-C

 TRUE FALSE

Solution:

1. **True**

In the ABC gene model for monocots, gene A, controlling sepal development, cannot be expressed alone. Also seen in Fig. B.

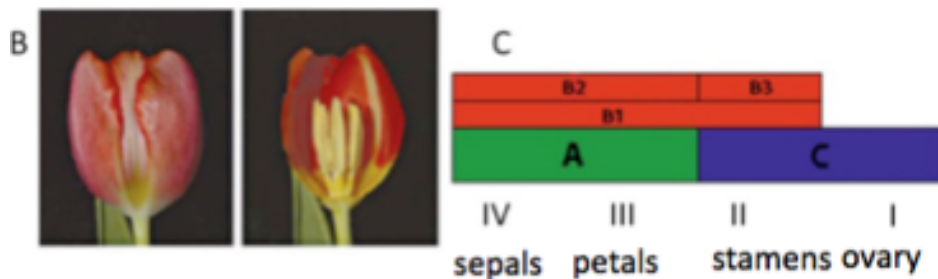

2. **False**

Gene C is expected to have the same expression in both groups, because both have stamens and ovary.

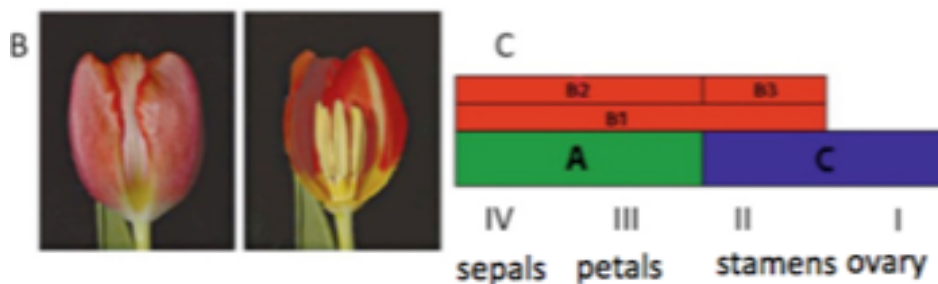

3. **True**

Deletion of parts of gene-C could lead to both male and female flowers, depending on whether the deletion affects the "right" or "left" part, respectively.

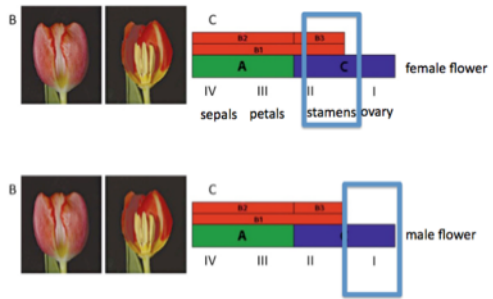

4. True

Gene-B1, gene-B3 and gene-C expressed together lead to the development of stamens.

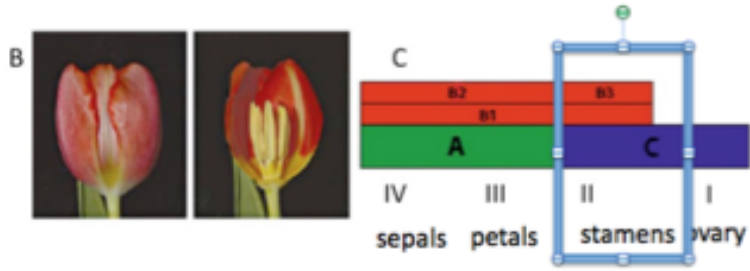

Q. 19

In the sea, O₂ diffuses from the free water down into the top oxic layer in the sediment and here becomes reduced to water. Anoxic layers are beneath this layer, and here bacteria-mediated processes take place. One process is the oxidation of H₂S to SO₄²⁻, which is tightly coupled to the O₂-reduction in the oxic layer above. This coupling between oxic and anoxic processes can only be explained by "electric currents" transporting electrons from H₂S oxidation to O₂ reduction. In experiments, attempts were made to identify the electron conductor (Fig.).

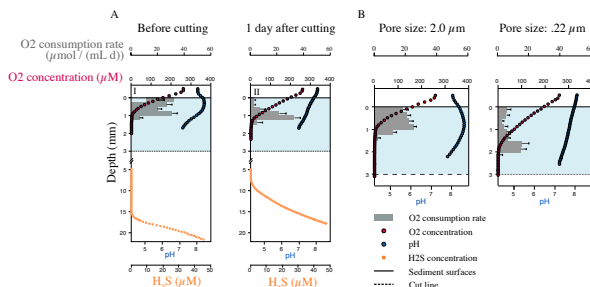

In an experimental set-up, upper oxic (< 3 mm, blue area) and lower anoxic sediment layer (> 3 mm) were: A, physically cut apart by a thin "knife" (before: left diagram, and after: right diagram); B, the two layers were separated by filters with pores of two sizes (lower horizontal line) (from Pfeffer et al. 2012). O₂ concentration (red curve), O₂ consumption rate (O₂ c.r., grey-coloured histogram), pH (blue), H₂S (orange line) and sediment surface (upper grey line at value 0) are shown (after Pfeffer et al. 2012)

Indicate if each of the following statements is true or false.

TRUE FALSE

The pH peak in the oxic layer is due to production of water from oxygen

TRUE FALSE

Physically interrupting the sediment by the "knife" did not affect O₂ reduction

TRUE FALSE

The filters demonstrated that any specific solutes were not transporting the electrons

TRUE FALSE

Electrons for the O₂-reduction most likely came from donors in the oxic layer

TRUE FALSE

Solution:

1. True

O₂ + 4H⁺ + 4e⁻ -> 2H₂O results in a reduced H⁺ concentration and thus an increase in pH. The objective of the paper behind this question was to identify where these electrons came from.

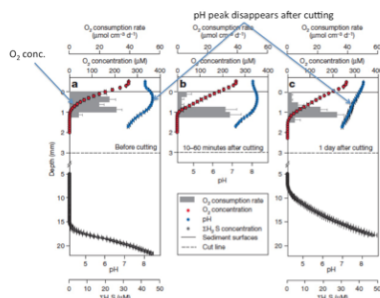

2. False

The O₂ profile (red curve) in the oxic zone is not affected, but the pH peak disappeared (blue curve), which indicates that O₂ reduction was interrupted by this disturbance. This was used as one of the evidences by the authors for a presence of filamentous bacteria, important to the electron transport between anoxic and oxic layers, i.e. the filaments were cut apart by the "knife".

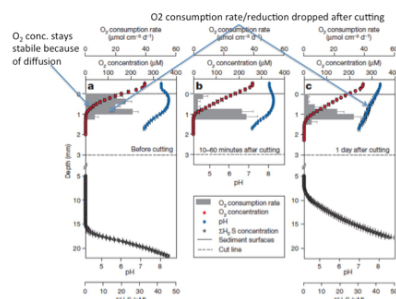

3. True

Only if filters with pores ≥ 0.8 μm were used, did the characteristic pH profile appear, showing that organisms larger than > 0.8 μm

(bacteria) were involved and not solutes (transport molecules), which would have passed filters of all pore sizes (at least down to 0.22 μm).

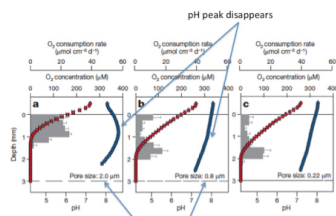

The electron-transporting bacteria can grow through this filter, i.e. there is an influx of electrons from below

4. False

There is a pH peak in the oxic layer, confirming a consumption of protons [H⁺], which is in accordance with cathodic electron donation. Photosynthesis is not possible in the darkness.

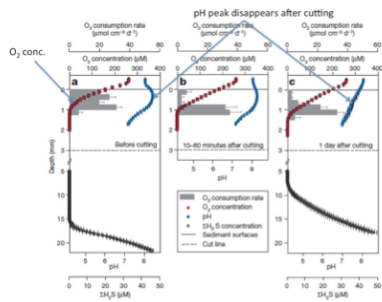

Q. 20

In an experiment, two bacterial strains, I and II, were allowed to conjugate. Strain I contained genes allowing it to grow on media lacking arginine and uracil, and with galactose as its sole carbon source, and even in the presence of the antibiotic Kanamycin (+KM). Strain II could not grow on these media. After a certain incubation time, Strain II was grown on selective media until 100 isolated colonies were obtained. The success of conjugation was assessed (Tab.).

Table. Success of growth of Strain II in (%) after conjugation.

Incubation time of conjugation (min)	5 min	10 min	15 min	20 min	25 min	30 min
Complete medium	100	100	100	100	100	100
Without arginine	0	4	100	100	100	100
Without uracil	5	98	100	100	100	100
With galactose	0	0	0	0	2	100
With KM	4	6	2	6	99	100

Indicate if each of the following statements is true or false.

TRUE FALSE

The gene marker 'KM resistance' is transferred before the gene required for uracil synthesis

The data suggest that a full bacterial genome can be transferred via conjugation in less than 15 minutes

The data suggest that a small fraction of recipient colonies can be expected to grow on +KM medium even in the absence of conjugation

More than 20% of all colonies incubated for 15 minutes are expected to grow on a medium lacking both arginine and uracil

Solution:

1. **False**

Kanamycin resistance gene is transferred after 20-25 min, whereas the gene necessary to synthesize Uracil is transferred after 5-10 minutes.

Incubation time (min)	5 min	10
-Uracil	5	
+KM	4	

2. **False**

The data suggest that it takes at least 30 min (the last gene being related to the use of Galactose). In general, only a fragment of the donor chromosome appears in the recipient, owing to spontaneous breakage of the mating pairs; so the entire chromosome is rarely transferred.

Incubation time (min)	5 min	10 min	15 min	20 min
-Arginine	0	4	100	100
-Uracil	5	98	100	100
+Galactose	0	0	0	0
+KM	4	6	2	6

3. **True**

During the first 5 minutes, the experiment with KM shows a small fraction of growth between 4%, and after 25 min 99%. This indicates a natural mutation rate of about 4 % for gene conferring resistance to Kanamycin.

Incubation time (min)	
+KM	

4. True

In this experiment, the success rate of growth is 100% after 15 min on the -Arginine as well as the -Uracil medium.

Incubation time (min)	5 min	10
-Arginine	0	
-Uracil	5	

Q. 21

Cholera is caused by a toxin secreted by the bacterium *Vibrio cholerae* (Fig. A). One symptom is severe diarrhea, which leads to dehydration and perhaps death. Scientists tested a new CFTR-inhibitor, CFTR-172 (Fig. B) as a potential treatment for cholera.

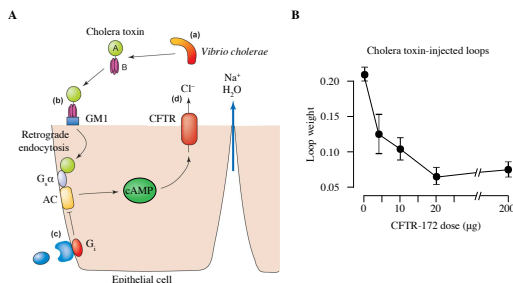

A, action of cholera toxin on an intestinal epithelial cell. In the figure, A and B are cholera toxin subunits; GM1 (GM1 ganglioside receptor); Gsa (G protein); AC (adenylate cyclase); Gi (G protein); cAMP (cyclic AMP); and CFTR (cystic fibrosis transmembrane conductance regulator Cl- channel); B, dose-dependent reaction of cholera toxin-induced fluid secretion into closed loops of mouse ileum as a function of applied 'CFTR-172' dose (the small molecule 'CFTR-172' was injected into the body cavity).

After the 2010-earthquake in Haiti, a cholera outbreak led to discussions about the origin of the epidemic (Fig. C). Two theories were proposed: Either the infection originated from similar cases in Peru, or UN-soldiers from near Bangladesh carried it to the island, when they came to help after the earthquake.

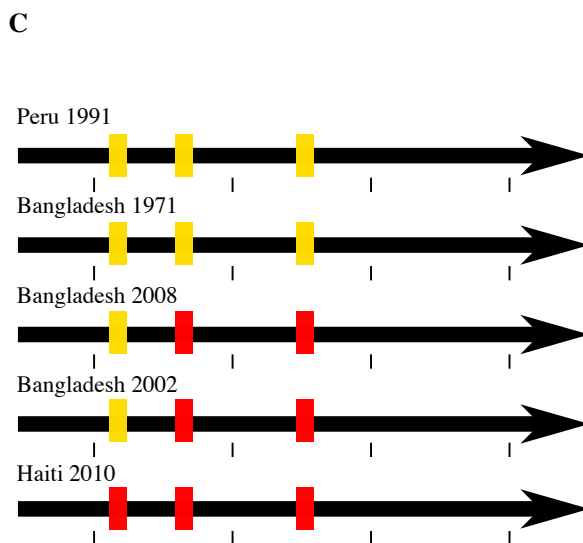

C, five variants of the cholera enterotoxin subunit B open reading frame. "Yellow" loci differ from "red" loci. Labels tell where each variant has caused cholera (from Thiagarajah & Verkman 2005, Chen-Shan et al. 2011).

Indicate if each of the following statements is true or false.

The water loss of patients with cholera is due to osmosis

The cholera toxin binds to transmembrane ion channels thereby starting a cascade reaction

Based on Figure B, one might treat cholera-induced diarrhea with CFTR inhibitor, CFTR 172

The results in Fig. C support that the cholera outbreak could be caused by infection from the UN soldiers

TRUE	FALSE
<input type="radio"/>	<input type="radio"/>
<input type="radio"/>	<input type="radio"/>
<input type="radio"/>	<input type="radio"/>
<input type="radio"/>	<input type="radio"/>

Solution:

1. True

As CFTR channels are activated by cyclic AMP, the increased concentration of cyclic AMP causes the CFTR channels to open and stay open. They pump chloride ions (Cl-) out of the cell into the lumen (the inside of the small intestine tube). Sodium ions (Na+) are attracted to the negative chloride ions, so they also leave the cell. With more ions in the lumen, the lumen has a lower water potential. This makes water leave the cells lining the lumen by **osmosis**, down the concentration gradient.

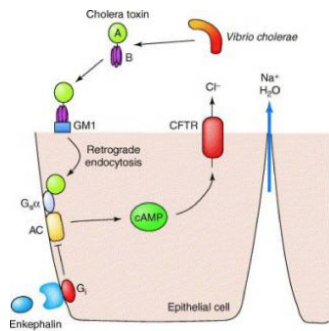

2. **False**

The toxin binds to a G-protein mediated receptor; GM1 in Fig. A. The student should know the difference between cell surface (membrane) receptors and ion channels (Knowledge).

Ion channels are pore-forming membrane proteins whose functions include establishing a resting membrane potential, shaping action potentials and other electrical signals by gating the flow of ions across the cell membrane, controlling the flow of ions across secretory and epithelial cells, and regulating cell volume

Cell surface receptors (membrane receptors, transmembrane receptors) are specialized integral membrane proteins that take part in communication between the cell and the outside world. Extracellular signaling molecules (usually hormones, neurotransmitters, cytokines, growth factors or cell recognition molecules) attach to the receptor, triggering changes in the function of the cell.

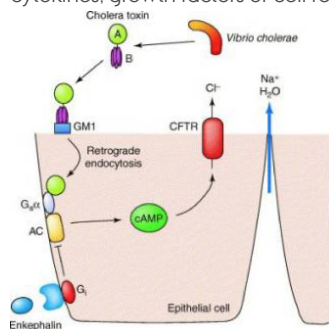

3. **True**

Inhibitors of CFTR-172 stop the efflux of ions and the resulting osmotic efflux of H₂O. This works by reducing secretion through the CFTR-172 Cl-K channels.

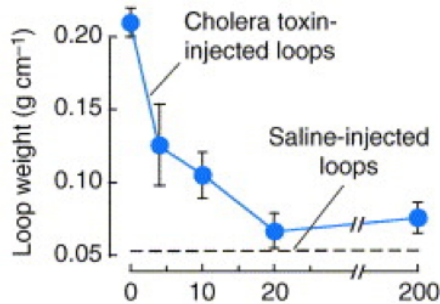

4. **True**

The DNA variant on Haiti was closest to those from South East Asia (Bangladesh CIRS101) and less similar to the geographically closest – the South American (Peru) sample.

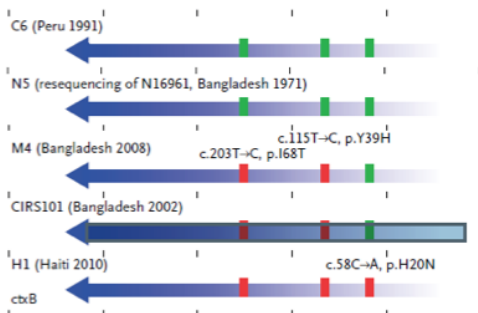

Q. 22

Staphylococcus aureus (SA) causes skin infection in humans and is a common cause of death. Immediate protection or intervention by local epithelial cells restrict spread of infection. These cells produce antimicrobial peptides (amp), e.g. cathelicidin (Camp). A newly discovered host response to such infections is changes in subcutaneous adipose (fat) tissue (fig A-B). The antibacterial role of this was studied by using BADGE, an ether that inhibits adipogenesis (fig C-E)

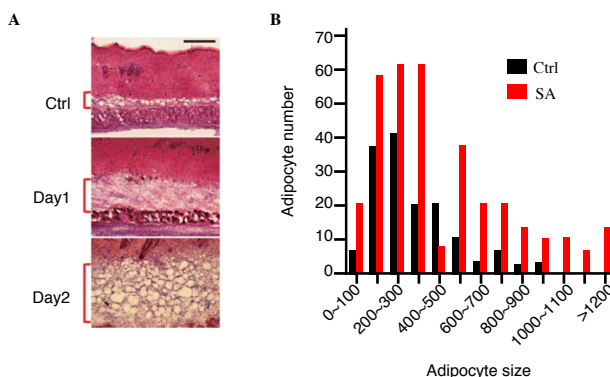

A, mouse skin infected with SA and compared to control (ctrl) (red brackets: subcutaneous fat layer); B, change in number and size of adipocytes 3 days after SA infection.

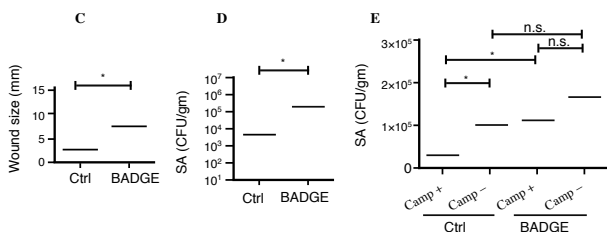

C-D, effects of BADGE on wound size and SA CFU (the ether BADGE inhibits adipogenesis, CFU=Colony-Forming Units); E, effects of + and - Camp (*, significant differences; n.s., no difference (from Zhang et al. 2015).

Indicate if each of the following statements is true or false.

TRUE FALSE

An SA infection induces the average subcutaneous fat cell to increase in size

TRUE FALSE

Number of adipocytes is important against spread of infection

TRUE FALSE

Badge destroys the effect of Camp

TRUE FALSE

Results in Fig. C-D and in Fig. E support each other well

TRUE FALSE

Solution:

- True**
Concluded from Fig. A-B. The fat layer increases rapidly in thickness and so does the size of adipocytes.
- True**
The results only say that the number increases but not that it has any effect.
- False**
A significant effect is seen in Fig. E.

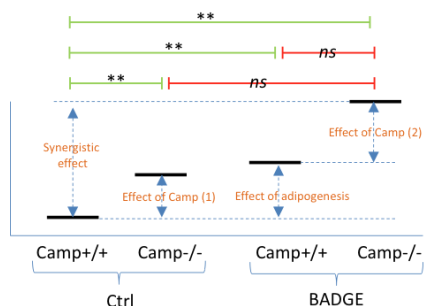

4. **True**

Fig. D shows a significant effect of blocking the adipogenesis with BADGE. This effect is also present (Fig. E: comparison of Control (Camp +/+) and BADGE (Camp +/+).

Q. 23

The effect of the nodule bacterium *Rhizobium* on the growth of the legume *Lotus japonicus* has often been studied, e.g. in relation to the enzyme/gene system of the interaction (Fig.).

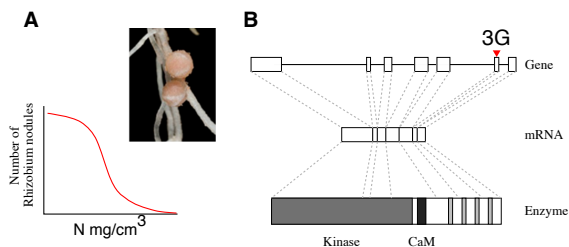

A, *Rhizobium* nodule and the relationship between the number of *Rhizobium* nodules and the nitrogen (N) content of soil. B, the enzyme CaMK with its mRNA and associated gene. The kinase domain (large dark grey) regulates other enzymes. The black band is the CaM domain, and the four narrow grey bands are EF-hand domains. Boxes in the gene are exons.

Indicate if each of the following statements is true or false.

Nodulation mainly occurs in nitrogen-poor soil

Rhizobium stimulates growth of *Lotus* by enlarging the surface of its root system; and consequently uptake of NO₃⁻ increases

Mutation 3G in Fig. B inhibits the transcription of CaMK

Each exon encodes a specific protein domain

Solution:

- True**
This is seen from the figure. The bacterium emits signals that stimulate root hairs to elongate and make nodules if N is a limiting factor. In rich soils, the plant cells will not spend energy to make the nodules.
- False**
The mechanism behind the stronger growth in the presence of *Rhizobium* is different: *Rhizobium* fixes atmospheric N₂ and supplies it ultimately to the plant as ammonium, which increases growth of the aboveground parts of the plants (Knowledge).

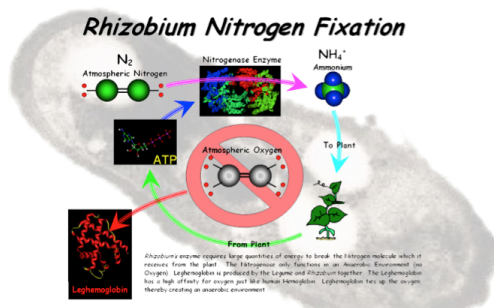

- False**
Mutation 1G is located in an intron and thus not part of the transcription or protein.

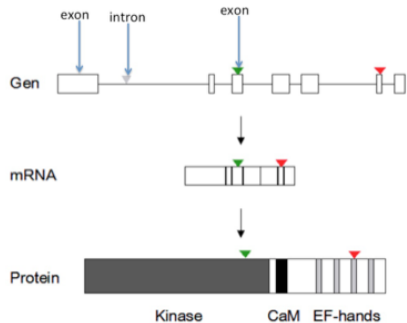

- False**
The exon structure of a gene is not related to the domain structure of the corresponding protein. An exon can encode fragments, or one or multiple complete protein domains (Knowledge).

Q. 24

The Galápagos Islands are well known for the adaptive radiation of 14 species of finch. The drivers of this radiation are either competition for food in the community of finch species (Hypothesis 1), diversity of available food, i.e. seeds and fruits (Hypothesis 2), or both. Choice of diet is determined by size and structure of the beak. These hypotheses were tested using the six ground finches, which have very different beaks (Fig.).

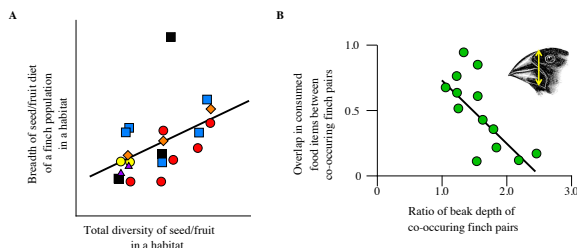

A, relationship between seed/fruit diversity within a habitat and breadth of seed/fruit diet of a finch population in the same habitat. Each dot is a finch population in a habitat, and different shapes and colours of dots indicate different finch species; B, relationship between ratio of beak depth of co-occurring pairs of finch species and overlap in consumed food items between a pair of species, i.e. each dot is a species pair. Yellow arrow on inserted finch head indicates beak depth (from Abbott et al. 1977).

Indicate if each of the following statements is true or false.

	TRUE	FALSE
According to Fig. A, Hypothesis 2 is more likely than Hypothesis 1	<input type="radio"/>	<input type="radio"/>
According to Fig. B, Hypothesis 1 is more likely than Hypothesis 2	<input type="radio"/>	<input type="radio"/>
Different finch species respond to the same extent to an increase in seed and fruit diversity	<input type="radio"/>	<input type="radio"/>
Figures A–B show that interspecific competition is low when food is more diverse	<input type="radio"/>	<input type="radio"/>

Solution:

1. True

X: Total diversity of seed/fruit within a habitat
 Y: Width of seed/fruit diet of a finch population in the same habitat

The positive relationship in Fig. A tells, that the diet of a finch species tends to broaden as the variety of available seed and fruit increases. Thus, at least to some extent, diet breadth appears to be a function of food availability (supporting hypothesis 2).

Drivers of radiation:

Hypothesis 1: competition for food from the community of finch species
 Hypothesis 2: Diversity of available food, i.e. seeds and fruits

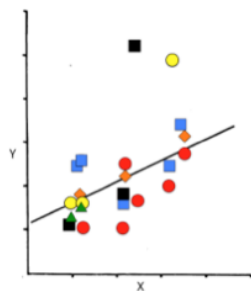

2. True

One prediction from hypothesis 1 is, that the more different in beak depth two sympatric finch species are, the less they should overlap in diet, i.e. the less they compete. That is supported by the negative relationship in Fig B, whereas if hypothesis 2 should be validated by these data we would not see any significant correlation between the variables, i.e. differences between birds would not matter.

Drivers of radiation:

Hypothesis 1: competition for food from the community of finch species
 Hypothesis 2: Diversity of available food, i.e. seeds and fruits

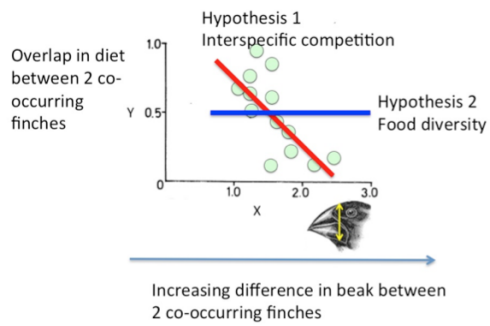
3. **False**

In Fig. A, the regression line (not drawn in the question page) for each finch species would differ in slope (e.g. the blue and black species respond differently) and thus, they do not respond in a similar manner to an increase in food diversity. Regression lines for each species are not given, only a regression for all species pooled.

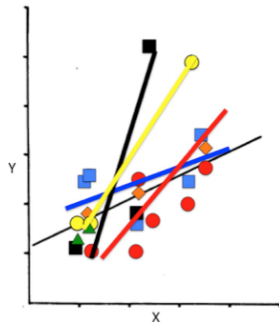
4. **True**

In Fig. A, we see that, when food becomes more abundant (more diverse), diet width increases, which must mean that interspecific diet overlap increases (unless available food diversity expands more than diet), which - in Fig. B - means that finches with quite similar beaks can coexist.

Q. 25

Rough-skinned Newts (a salamander) produce the toxin TTX, which is lethal to other vertebrates. Individual newts vary in their level of TTX. Garter Snakes eat almost any prey, including newts, and individual snakes vary in their resistance to TTX. The higher the TTX level in a newt population is, the greater the resistance of co-occurring snakes, which, however, still may reject newts, which are too poisonous (Fig.).

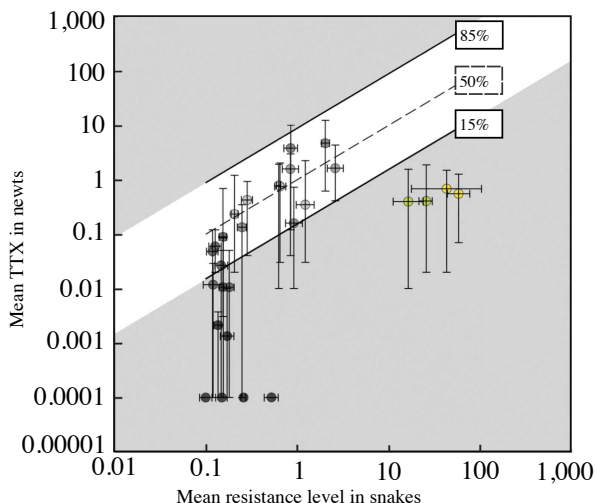

Relationship between levels of resistance of snakes and toxicity of newts. Each dot represents a site with interacting snake and newt populations. In the white zone, snakes consume newts, but with a cost to their mobility. Dots in grey-coloured zones are toxicity/resistance mismatches. Bars give variation in levels among individuals within a population. The 50% dashed line reflects the TTX dose that would reduce snake performance 50%. 15% and 85% lines delimit the range of functionally relevant TTX doses for snakes across all sampled sites (from Hanifin et al. 2008).

Indicate if each of the following statements is true or false.

TRUE FALSE

Coevolution/reciprocal selection between newt and snake mainly takes place in the white zone

TRUE FALSE

The figure agrees with the "life-dinner principle", i.e. survival is under stronger selection than demand for food in a prey-predator interaction

TRUE FALSE

Per individual, resistance seems to be less costly than toxin production

TRUE FALSE

It is likely that the snake populations in the two 'green' and two 'yellow' sites at the extreme right of the figure have won the arms race.

TRUE FALSE

Solution:

1. True

When interacting newt and snake have roughly matched abilities (the white zone), the potential for strong reciprocal selection exists. In the white zone, reciprocal selection is taking place, i.e. there is an arms race (coevolution) between the two interacting populations - potentially moving the population pair upwards towards the right in the white zone. In the grey zones, reciprocal selection no longer occurs, and the coevolutionary process for this pair of populations is largely suspended.

2. False

The results in the figure appear to contradict predictions arising from "life-dinner principle", i.e. all the sites in the lower grey zone means that snakes have a resistance that is higher than "needed". The reasons are unknown according to the reference.

Add. There is a large difference in intraspecific variation in toxicity and in resistance. The low variance among snakes may be due to the genetic background, maybe only few alleles are involved quickly leading to fixation and a high level of resistance. In addition, the system is probably not in any equilibrium, because other predators and prey may be involved.

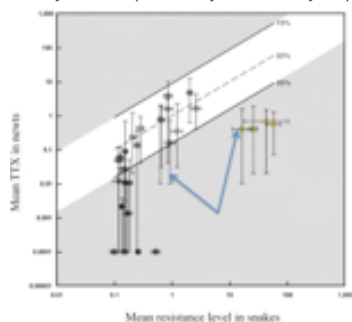

3. True

All species pairs outside the white zone are to different extent mismatches and all show an overshoot in resistance. Thus the researchers conclude that resistance is less costly than toxin production.

4. **False**

Newts can produce more TTX as seen in some of the uppermost grey populations (red arrow), but it could be true, if the newt populations at the green and yellow sites have run out of genetic variation (that is why the statement has a 'likely').

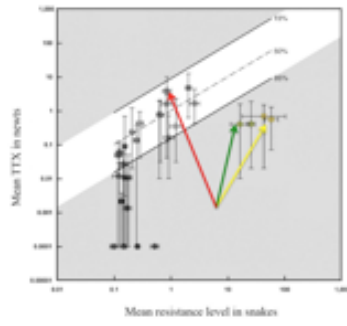

Q. 26

The Aleutians Islands west of Alaska are rich in sea birds. The Arctic Fox was not originally present here, but was introduced as a fur game-animal and is now present on many islands. The fox decimates sea bird populations severely. Indirect effects of foxes on island vegetation were compared on islands with and without foxes (Fig.).

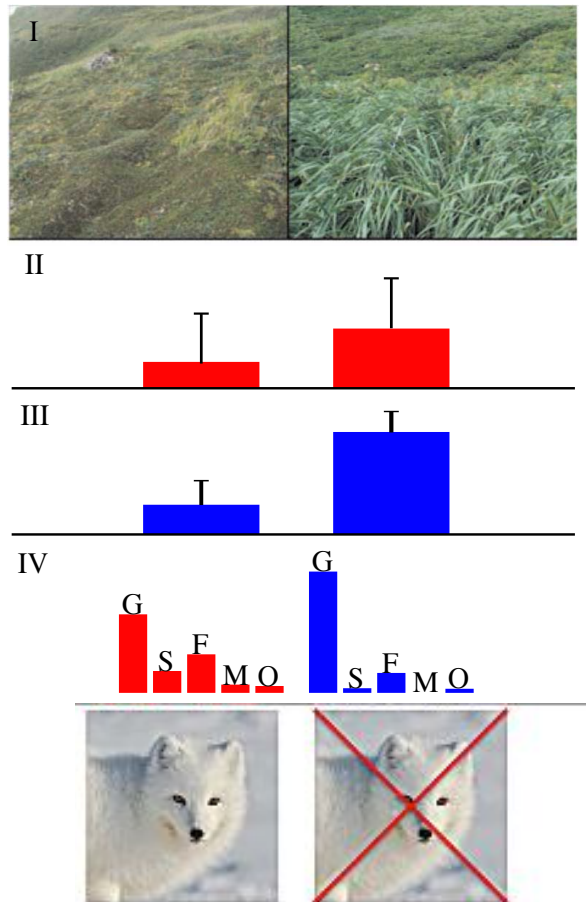

Mean values (\pm standard error) for parameters sampled on fox-infested islands (red, left-hand bars) and fox-free islands (blue, right-hand bars). I, view of the plant community on an island; II, logarithm₁₀ of density of breeding sea birds; III, total soil Phosphorus; and IV, relative abundance of grasses (G), shrubs (S), non-grass herbs (F, forbs), mosses (M), and others (O) (from Croll et al. 2005).

Indicate if each of the following statements is true or false.

TRUE FALSE

The study is based on the assumption that sea bird-derived nutrients are distributed all over an island

 TRUE FALSE

The presence of foxes on an island changes the vegetation from grassland to tundra- shrubland

 TRUE FALSE

Diversity and number of major plant groups are reduced in islands with fox populations

 TRUE FALSE

The ecological changes on islands with fox introduction represent exclusively top-down processes

 TRUE FALSE

Solution:

1. **True**

If not, vegetation changes would only been seen along the coast where most seabirds breed. This is probably not the case, but of course the scientists may make the assumption.

2. **True**

This is seen in I (A in the question) and IV (D in the question), where the shrub bar is higher and the grass bar lower on fox islands than on fox-free islands.

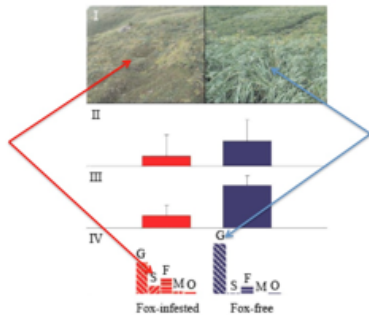

3. **False**

On fox islands, we have at least 5 functional plant groups represented, whereas in fox-free islands there are only grass and forbs. The fox-free islands are less diverse and have a lower evenness, i.e. a more variable relative abundance. A forb is a herbaceous flowering plant that is not a graminoid (grasses, sedges and rushes).

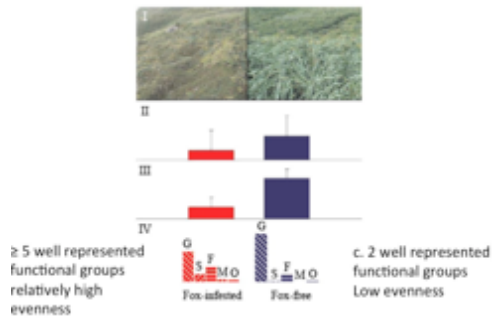

4. **False**

A top-down process runs from predator, to herbivore to plants. However, here the top-down process from fox to birds to guano is supplemented by an upward process from seabird guano to soil nutrients (total-phosphor) to vegetation. (Thus info about P in figure is needed to answer statement 4.). Guano is rich in N, P and K.

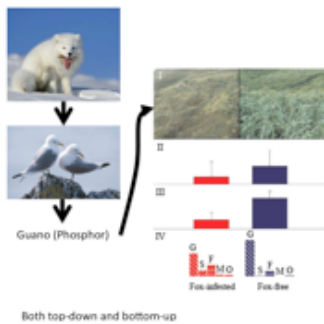

Both top-down and bottom-up

Q. 27

The bird Red-billed Chough has a wide diet. It lives on the oceanic Spanish island La Palma (IS) and on mainland Spain (MA). The bird's diet on IS and MA was compared (Fig.). As a food source, invertebrates are rich in protein and lipid, whereas fleshy fruit is rich in carbohydrates. IS-nestlings have more poorly developed feather barbs than MA-nestlings.

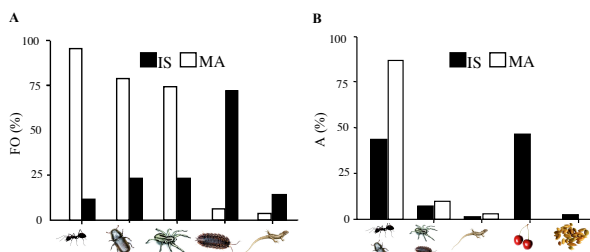

A, frequency of occurrence in habitat (FO%, i.e. percentage of samples with a given food item) of animal groups (from left: Ants, Other insects, Spiders, Other arthropods (i.e. myriapods, woodlice), and Lizards); B, chough nestling diet (A%: relative abundance of food item in diet, i.e. all white bars and all black bars each add up to 100%) (from left: Insects, Other arthropods, Other animals, Fleshy fruit, and Seeds) (from Blanco et al. 2014).

Indicate if each of the following statements is true or false.

Generally, food of animal origin is more scarce on IS than on MA

Mainland nestlings have a wider food niche than island populations

In general, insects are the favorite food of nestlings

Island nestlings are expected to have a faster growth rate and shorter generation time than mainland nestlings

TRUE	FALSE
<input type="radio"/>	<input type="radio"/>
<input type="radio"/>	<input type="radio"/>
<input type="radio"/>	<input type="radio"/>
<input type="radio"/>	<input type="radio"/>

Solution:

1. True

FO means in how many samples (%) a food item is found

Based on estimates of bar heights, only 28% of island samples include each of the five food items, whereas on mainland this figure is 50%.

food item	FO (%) Island	FO (%) Mainland
Ants	10	90
Other insects	24	76
Spiders	24	74
Other arthropods	70	7
Lizards	12	3
Mean	28	50

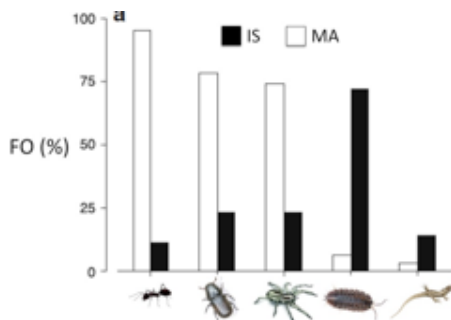

2. False

Fig. B shows that island birds consume food from all five categories, whereas mainland birds only choose food from three (perhaps four). The reason is that island birds also consume vegetative matter, which is not seen among mainland birds.

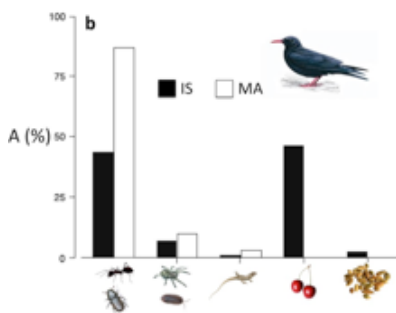

3. True

It can be seen intuitively from the figures or it can be calculated in a simple way as (the proportion of a food item in the diet)/(proportion of that food item in the habitat), f.eks.

Ants+other insects on islands: $45 / (10 + 24) = 1.3$. Ants+other insects on mainland: $90 / (90 + 76) = 0.5$.

To both island and mainland nestlings, insects are preferred, but based on the calculations it can be seen that only on islands are insects preferred to a higher degree than their presence in the habitat.

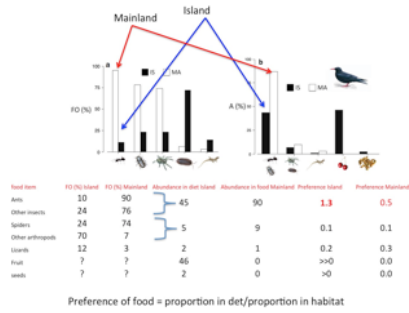

4. False

A main diet component of *IS* birds is carbohydrate-rich fruit, and not lipid-rich arthropods. *IS*-birds are thus supposed to grow slower on this poorer diet and they might become malnourished (as stated in the introduction to the question: "On *IS*, nestlings have more fault feather bars than *MA*-nestlings.").

Within a single year, the Amazon floodplain forests have a high-water (HW) and a low-water (LW) season with a high and low fruit production, respectively. Fruit consumption is widespread among Amazonian fishes, and the relationships between fish diet and fruit production have been explained by three hypotheses H1-H3 (Fig.). Two species of fish (*Brycon falcatatus* and *Myloplus asterias*) were studied in detail.

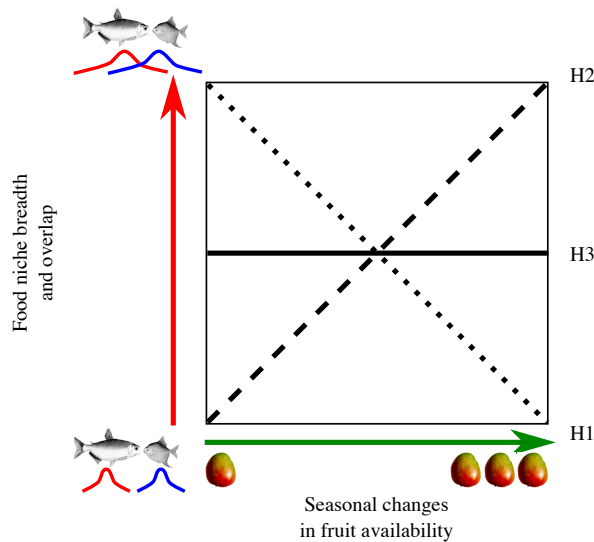

Three hypotheses (H1-H3) explain how food niche breadth and overlap among fish species (Y) respond to seasonal changes in fruit availability (X) (from Correa & Winemiller 2014).

TRUE FALSE

Fact: Diet overlap among fish increased from 28% to 95% from low-resource to high-resource season: This relationship is best explained by H1

Fact: *B. falcatatus* was, at first, observed not to change its food niche, when food became more plentiful, but then at higher food availability it became increasingly selective: This relationship is best explained by a combination of H1 and H3

Fact: Some fish had a constant food niche throughout the year, irrespectively of fruit availability: This is best explained by H1

Fact: During HW, *M. asterias* had a fruit-dominated diet, but switched to leaves instead of fruit in the LW season: This is best explained by H2

Solution:

1. **False**

According to Fig. 1, H1 states that diet overlap decreases with increasing fruit production. The observed increase in overlap is best explained by H2: increase in fruit production is related to an increased diet overlap.

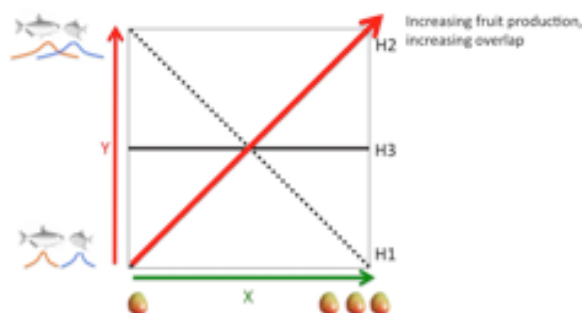

2. **True**

This is in accordance with Fig. 1. The food niche width of *B. falcatatus* stays constant from left (following H3, i.e. no change in food niche), but then it becomes more narrow at higher food availability (following H1).

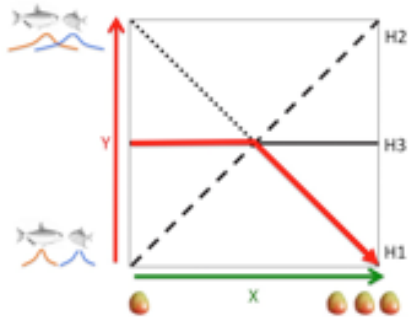
3. **False**

If true, they should follow H3, i.e. always consume a constant proportion of fruit and animal matter, irrespectively of how much fruit the forests produce.

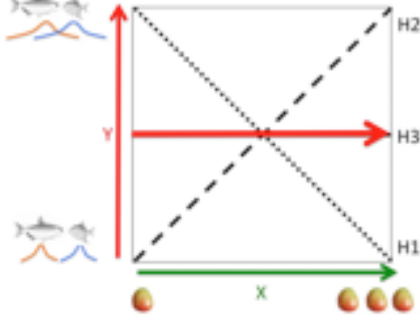
4. **True**

M. asterias behaves according to H2, shifting to leaves when fruit resources are scarcer and thus reducing overlap with other fish species, which might be more conservative and perhaps more competitive fruit consumers.

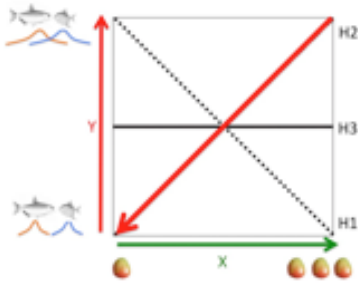

M. asterias switches to other vegetative matter when fruit becomes scarce

In 1986-1987 in Thailand, a water reservoir was established by flooding a forest area. In the reservoir, former hilltops now became new islands and on 16 of these, the small mammal fauna was monitored until 2013, i.e. 27 years after establishment (Fig.). The focus of the study was extinction of the hilltop fauna due to isolation.

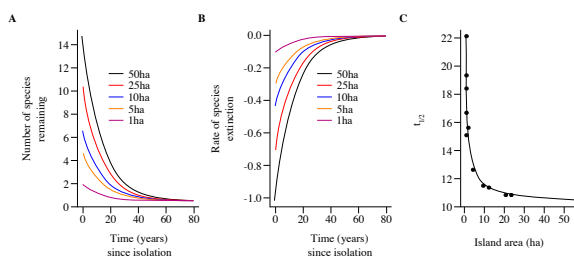

A, number of species remaining on different-sized islands (1–50 ha) T years after reservoir establishment (graph part after $T = 27$ years is expected future change); B, rate of species extinction on different-sized islands as a function of T ; C, time to extinction of half of the fauna ($T_{1/2}$) on different-sized islands (from Gibson et al. 2013).

Indicate if each of the following statements is true or false.

Smaller islands (1–10 ha) lose more species per year than larger islands (25–50 ha)

At reservoir establishment, a linear relationship existed between species number and island area

The study supports the hypothesis that in the long run, a single large protected island will support biodiversity better than several small ones

In all islands, which are larger than 10 ha, the mean time to extinction of half of all species, is comparable

TRUE FALSE

Solution:

1. False

According to Figure A, large fragments lose more species (actual numbers) per year than small islands – the curves for large islands are above the curves for small islands (they had more species from the beginning). In Fig. B, curves for large islands are steeper (have higher extinction rate) than curves for small islands. Fig. C also shows that large fragments quickly lose half of their species (they have a short $T_{1/2}$).

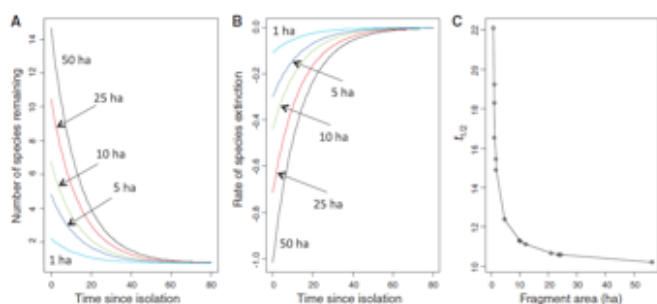

2. False

In Fig. A at $T = 0$, it can be seen that species number to some extent follows the logarithm of area (a classic species–area saturation relationship); at least it is far from linear (see right figure).

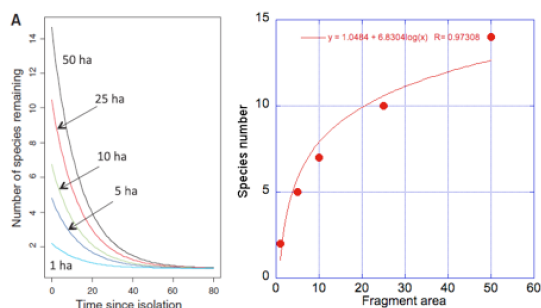

3. False

The results show that whatever the size of fragments, only one species is expected to remain (that is the Malayan field rat).

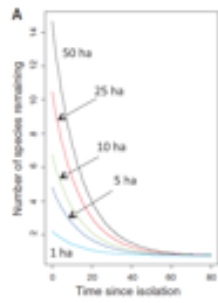

4. **True**

Figure C shows that half-lifetime expectancy is almost constant for large fragments (>10ha).

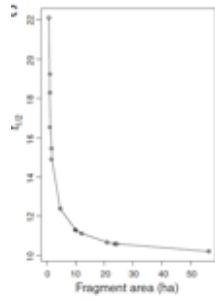

Q. 30

Stephen Emlen experimentally studied seasonal migration of an American bird, the Indigo bunting. He used a funnel-shaped test cage (Fig. B), at the bottom of which he placed an ink pad. Each time a bunting tried to fly out of the cage, the location of its footprint was marked by ink on a piece of paper, so its orientation pattern easily could be recorded (Fig. C). The bird migrates at night, using stars as cues.

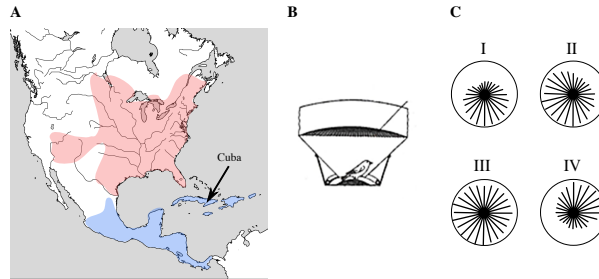

A, distributional range of the bird (pink area = summer range; blue area = winter area); B, Emlen's experimental cage; and C, four examples of footprint pattern; each radius is a take-off attempt by the bird (from Emlen 1967).

Indicate if each of the following statements is true or false.

TRUE FALSE

The bird breeds in Central America and the Caribbean (blue area, Fig. A)

TRUE FALSE

Fig. C-I is made by a north-eastern USA bird ready for autumn migration to the western part of Central America

TRUE FALSE

Fig. C-II is made by a western USA bird ready for autumn migration to Cuba

TRUE FALSE

Fig. C-III: The footprint of a young bird, suggesting that migration patterns are genetically determined

TRUE FALSE

Solution:

1. **False**

In spring the bird migrates north and in autumn south, and it breeds in the north (Knowledge).



2. **False**

The migration direction is directly south, and thus according to the experiment has to be from western US and directly south to Central America. The correct paper is C-II.



3. **False**

The migration direction is south-west, and thus according to the experiment has to be from northeastern US and south-west to Central America, not directly south to Cuba. A correct departure paper would show radii towards 5 o'clock (south-east).

4. **False**

The opposite is the case. The young bird has no clue about where to fly, i.e. the radii are pointing in all directions.

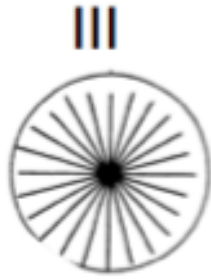

About 100 individuals of the butterfly *Melitaea cinxia* lives on a tiny island PT in the Gulf of Finland. Researchers studied how the butterflies on PT coped with the very windy conditions on the island. In the lab, they exposed butterflies from mainland and PT to a wind source (hair dryer) (Fig. B) and they also studied the morphology of the claws of the butterfly (Fig. C).

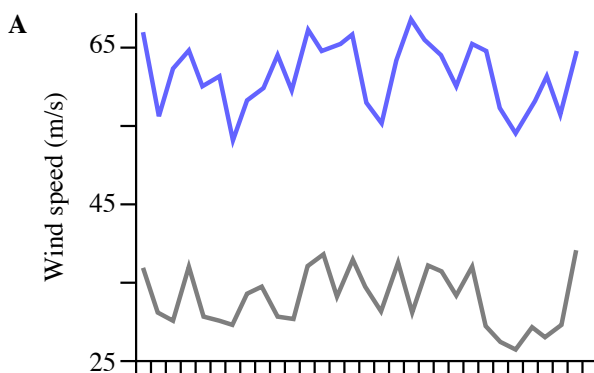

A. wind speed in June on PT (blue) and mainland (gray)

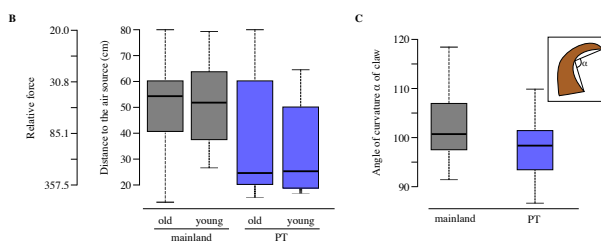

B. distance (cm) to wind source, when a butterfly loses its grip on a surface; old and young butterflies from mainland (grey boxes) and PT (blue boxes) are compared (mainland vs. PT, $p = 0.003$); C. The angle of curvature of tarsal claw on mainland (grey box) and PT (blue box) (mainland vs. PT, $p = 0.001$). The inset indicates the tarsal claw, with its angle of curvature and how it is measured. (from Duplouy & Hanski 2014).

Indicate if each of the following statements is true or false.

TRUE FALSE

Island insects in general are more often flightless than are mainland insects

If more curved tarsal claws are a disadvantage in escaping predators, then PT probably has very few insect-eating birds as compared to mainland localities

In general, butterflies do not evolve flightlessness because of their mode of foraging

With age, island butterflies learn to hide from the wind

Solution:

- True**
In some island species, there is a selection against long-distance dispersal, because of the high risk of being blown to sea and the fewer predators on islands (Knowledge).
- True**
The strongly curved claws make rapid escape problematic, but increases the butterfly's chances to withstand the strong winds.
- True**
Flightlessness would not normally evolve in animals that have to fly for foraging (flower visitation) (Knowledge).
- False**
Fig. B shows that this is not the case; young and old individuals have the same ability to withstand wind.

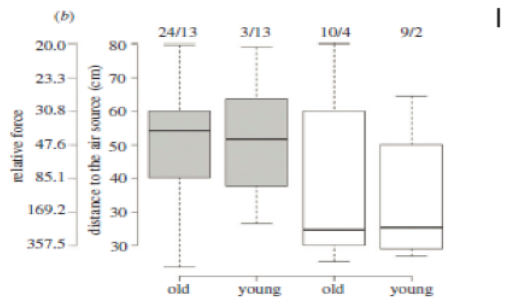

Q. 32

In farms, a study of mink looked at how reduced welfare, e.g. postponed feeding, led to abnormal behaviours, such as stereotypic pacing and tail-chewing. Indicators of abnormal behaviours could also be elevated levels of the hormone cortisol and increased fearfulness. Based on their behavioural response to stress, minks were classified into three groups, NST = no stereotypic pacing, ST1 = low level of pacing and ST2 = high level of pacing. The differences between these groups of minks in their stress responses to postponed feeding are shown in figures A and B.

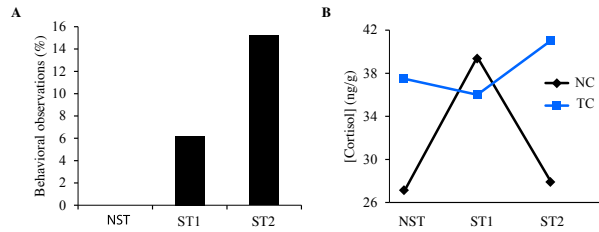

A, frequency of stereotypic pacing, caused by postponed feeding; B, mean cortisol concentration in the two stereotypic groups (ST1 and ST2) and in the control (NST), and in absence (NC) or presence of tail-chewing (TC) (from Svendsen et al. 2013).

Indicate if each of the following statements is true or false.

Animal welfare studies always require behavioural observations

TRUE FALSE

Stereotypic pacing is affected by postponed feeding

TRUE FALSE

Tail-chewing and stereotypic pacing are closely correlated

TRUE FALSE

Very high behavioural stress levels seem to suppress cortisol production

TRUE FALSE

Solution:

1. **False**

Cortisol level can also be used, because it varies with stress level (Fig. B).

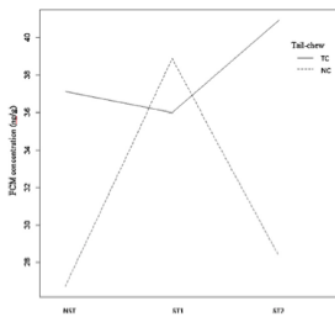

2. **True**

If exposed to postponed feeding, the mink shows increased stereotypic behaviour (Fig. A). The problem with Fig. A is, that it does not include the NST data. However, using ST1 as a control to ST2 we see that the frequency of stereotypic behaviour increases.

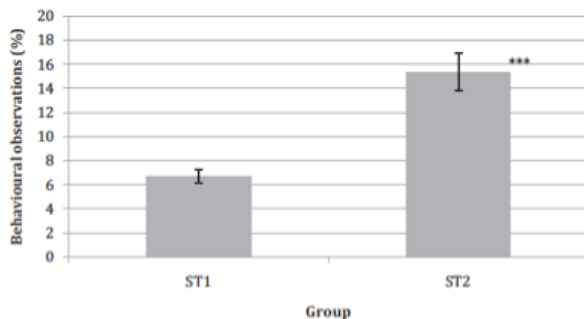

3. **False**

According to Fig. B, tail chewing and stereotypic behavior are not correlated. Tail chewing takes place even in the non-stressed (NST) group.

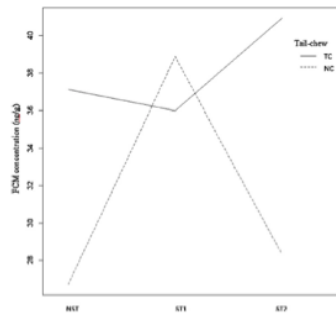

4. True

According to Fig. B, the ST2 has a low cortisol production. The reason is not known. Normally when cortisol reaches a certain level it automatically shuts off the mechanisms that signal for it, therefore limiting production. The hypothalamus, when it senses a stressor, produces CRH (corticotropin releasing hormone), which then stimulates the anterior pituitary gland to produce ACTH, which then stimulates the adrenal gland to produce cortisol. When cortisol levels get high a negative feedback message is sent to the hypothalamus and the anterior pituitary.

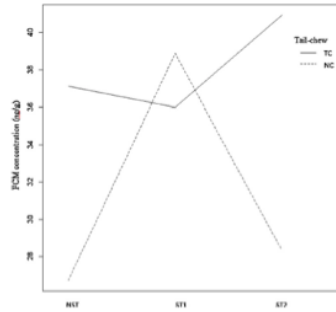

Q. 33

In order to make safe blood transfusions, we have to know the blood types of both patient and donor. Mixing incompatible blood types is dangerous and may be lethal. In this problem we consider only the ABO blood group system and transfusions that do not include plasma.

Indicate if each of the following statements is true or false.

TRUE FALSE

Blood transfusion with A-blood causes an incompatibility reaction in an O-recipient

TRUE FALSE

A traffic accident victim needed blood fast, and without knowing the blood group type of the victim the doctor prescribed blood of type O, and the patient showed signs of incompatibility

TRUE FALSE

Persons with type AB can receive blood from all ABO types

TRUE FALSE

Persons with type B can receive blood of type AB

TRUE FALSE

Solution:

1. True

If A-red cells are infused into a recipient, who is group O, the recipient's anti-A antibodies bind to the transfused cells, which have A antigens. An ABO incompatible transfusion reaction may result in shock, renal failure & death (Knowledge).

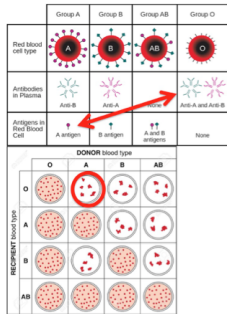

2. False

O-blood does not have any antigens, and can thus be given to all ABO blood types (Knowledge).

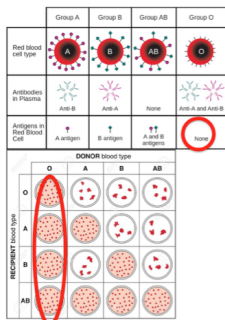

3. True

Individuals with type AB blood produce both A and B antigens and thus no antibodies. Therefore, they can receive blood from all types (Knowledge).

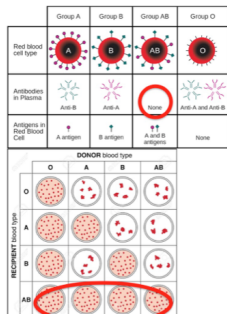

4. False

People with type B-blood will have B antigen on the surface of their red cells and antibody A in their blood. As a result, AB-blood, which contains both A and B antigen, will result in rejection (Knowledge).

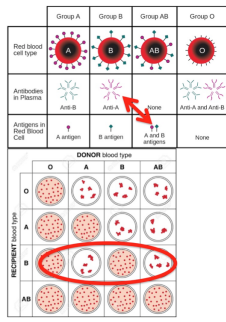

Q. 34

Use of environmental DNA (eDNA) is a new tool in tracking of marine organisms. In a study, a base sequence from the mitochondria of the cetacean Harbour Porpoise was analysed. Samples were taken both from a harbour pen and outside from natural sites (fig.).

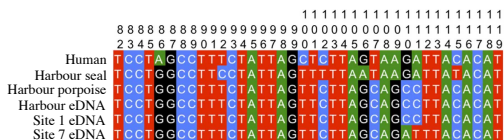

Base sequences (base no. 82 to 119) from human, seal, porpoise, and 3 samples of eDNA (Fjord Bælt, Site 1 and Site 7) (from Foote et al. 2012).

In addition, echolocation clicks were used for acoustic monitoring (table).

Detection of harbour porpoise DNA and sounds at 11 sites, including a control DNA from skin; values in right column are numbers of positive PCRs out of a sample of 3.

Location	Acoustic detection % Porpoise positive days	Genetic detection Positive PCRs
Positive control (DNA extracted from skin)		3/3
Fjord & Bælt pen		3/3
< 10 m from F&B pen		1/3
> 10 m from F&B pen		0/3
Site 1	94	1/3
Site 2	42	0/3
Site 3	63	0/3
Site 4	6	0/3
Site 5	0	0/3
Site 6	0	0/3
Site 7	0	2/3
Site 8	79	0/3

Indicate if each of the following statements is true or false.

TRUE FALSE

In this study eDNA may be an effective tool to detect marine animals far away from their habitat

Most likely, the eDNA from site 7 was from an animal more closely related to the porpoise than to harbour seal

Based on the short sequence in the Fig., the two marine animals, seal and porpoise, are more closely related to each other than seal and human are to each other

eDNA seems to be a poorer detection method than acoustic monitoring

Solution:

1. **False**

Very unlikely, at least based on this study. Already > 10 m away from the pen, it was not possible to detect eDNA (Table).

Location	Acoustic detection	Genetic detection
	% Porpoise positive days	Positive PCRs
Positive control (DNA extracted from skin)		3/3
Fjord&alt pen		3/3
<10 m from F&B pen		1/3
>10 m from F&B pen		0/3
Site 1	94	1/3
Site 2	42	0/3
Site 3	63	0/3
Site 4	6	0/3
Site 5	0	0/3
Site 6	0	0/3
Site 7	0	2/3
Site 8	79	0/3

2. True

The difference in the two sequences suggests this, and a run on Genbank confirmed that the finding at site 7 was another cetacean (Long-finned Pilot Whale): 8 base differences between Site 7 and seal, and one between Site 7 and porpoise (Fig.).

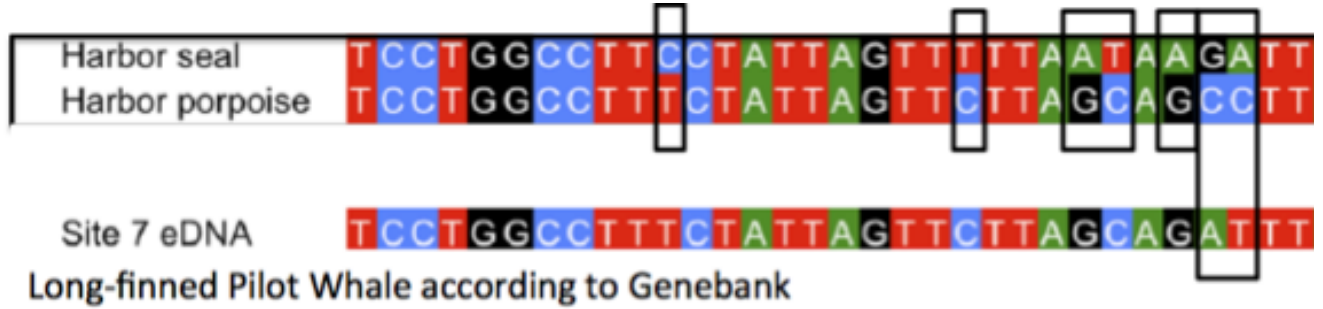

3. False

Six different bases between the seal and human and eight between seal and porpoise (Fig.).



4. True

One eDNA detection and four acoustic detections.

Most likely, eDNA is released too slowly into seawater, degrades too fast for detection of animals, visiting a site and spreads slowly.

Location	Acoustic detection	Genetic detection
	% Porpoise positive days	Positive PCRs
Positive control (DNA extracted from skin)		3/3
Fjord&alt pen		3/3
<10 m from F&B pen		1/3
>10 m from F&B pen		0/3
Site 1	94	1/3
Site 2	42	0/3
Site 3	63	0/3
Site 4	6	0/3
Site 5	0	0/3
Site 6	0	0/3
Site 7	0	2/3
Site 8	79	0/3



Q. 35

In a criminal case about rape, which was brought to court, four men (1–4; Table), the victim (Mother) and the resulting child (Daughter) (1–4, Table) were blood-type scored for ABO (alleles I^A and I^B are co-dominant, i recessive), Rhesus (allele Rh^+ dominant to Rh^-), MN (alleles M and N are co-dominant), and the X-linked $Xg^{(a)}$ (allele $Xg^{(a+)}$ dominant to $Xg^{(a-)}$). Results are shown in the Table.

Results of blood-type testing. Man 1–4 are potential fathers.

Individual	ABO phenotype	Rh phenotype	MN phenotype	$Xg^{(a)}$ phenotype
Mother	AB	Rh-	MN	$Xg^{(a+)}$
Daughter	A	Rh+	MN	$Xg^{(a-)}$
Man 1	AB	Rh+	M	$Xg^{(a+)}$
Man 2	A	Rh-	N	$Xg^{(a-)}$
Man 3	B	Rh+	N	$Xg^{(a-)}$
Man 4	O	Rh-	MN	$Xg^{(a-)}$

Indicate if each of the following statements is true or false.

TRUE FALSE

Both Man 2 and Man 3 can be the father

The father could be identified unambiguously with less than four blood type systems

Using the ABO system alone, the daughter's genotype had to be $I^A i$

If the daughter bears a boy with a man, whose genotype is $Xg^{(a+)}$, then her son must be $Xg^{(a+)}$, because the allele $Xg^{(a+)}$ is dominant

Solution:

1. False

Man 2 has the wrong Rhesus blood type (he should be Rh+, so he could pass on the Rh^+ allele). Man 3, on the other hand, could be the father.

Individual	ABO phenotype	Rh phenotype	MN phenotype	$Xg^{(a)}$ phenotype
Mother	AB: $I^A I^B$	Rh-: $Rh^- Rh^-$	MN: MN	$Xg^{(a+)}$: $Xg^{(a+)} Xg^{(a-)}$
Daughter	A: $I^A I^A$ or $I^A i$	Rh+: $Rh^+ Rh^+$ or $Rh^+ Rh^-$	MN: MN	$Xg^{(a-)}$: $Xg^{(a-)} Xg^{(a-)}$
Man 1	AB: $I^A I^B$	Rh+: $Rh^+ Rh^+$ or $Rh^+ Rh^-$	M: MM	$Xg^{(a+)}$: $Xg^{(a+)} Xg^{(a-)}$
Man 2	A: $I^A I^A$ or $I^A i$	Rh-: $Rh^- Rh^-$	N: NN	$Xg^{(a-)}$: $Xg^{(a-)} Xg^{(a-)}$
Man 3	B: $I^B I^B$ or $I^B i$	Rh+: $Rh^+ Rh^+$ or $Rh^+ Rh^-$	N: NN	$Xg^{(a-)}$: $Xg^{(a-)} Xg^{(a-)}$
Man 4	O: ii	Rh-: $Rh^- Rh^-$	MN: MN	$Xg^{(a-)}$: $Xg^{(a-)} Xg^{(a-)}$

No match

2. True

Rhesus and $Xg^{(a)}$ would have been sufficient in this case.

Individual	ABO phenotype	Rh phenotype	MN phenotype	$Xg^{(a)}$ phenotype
Mother	AB: $I^A I^B$	Rh-: $Rh^- Rh^-$	MN: MN	$Xg^{(a+)}$: $Xg^{(a+)} Xg^{(a-)}$
Daughter	A: $I^A I^A$ or $I^A i$	Rh+: $Rh^+ Rh^+$ or $Rh^+ Rh^-$	MN: MN	$Xg^{(a-)}$: $Xg^{(a-)} Xg^{(a-)}$
Man 1	AB: $I^A I^B$	Rh+: $Rh^+ Rh^+$ or $Rh^+ Rh^-$	M: MM	$Xg^{(a+)}$: $Xg^{(a+)} Xg^{(a-)}$
Man 2	A: $I^A I^A$ or $I^A i$	Rh-: $Rh^- Rh^-$	N: NN	$Xg^{(a-)}$: $Xg^{(a-)} Xg^{(a-)}$
Man 3	B: $I^B I^B$ or $I^B i$	Rh+: $Rh^+ Rh^+$ or $Rh^+ Rh^-$	N: NN	$Xg^{(a-)}$: $Xg^{(a-)} Xg^{(a-)}$
Man 4	O: ii	Rh-: $Rh^- Rh^-$	MN: MN	$Xg^{(a-)}$: $Xg^{(a-)} Xg^{(a-)}$

3. False

The daughter would get I^A from her mother and could get either I^A or i from Man 1-4. Thus we can not determine the ABO genotype from ABO alone.

Individual	ABO phenotype
Mother	AB: $I^A I^B$
Daughter	A: $I^A I^A$ or $I^A i$
Man 1	AB: $I^A I^B$
Man 2	A: $I^A I^A$ or $I^A i$
Man 3	B: $I^B I^B$ or $I^B i$
Man 4	O: ii

4. False

Boys inherit their X-chromosome from the mother, so in this case, all sons of the daughter will be $Xg^{(a-)}$.

Daughter: $Xg^{(a-)} Xg^{(a-)}$ — Father
 Boy: $Xg^{(a-)}$

Q. 36

Ficolins are important immune system proteins, e.g. ficolin-3. Consequently, patients with ficolin-3 deficiency may suffer from several complications. This deficiency is caused by a mutation in the ficolin exon (A).
 Samples of ficolin-3 in the blood from five family members were analyzed, using electrophoresis (B).

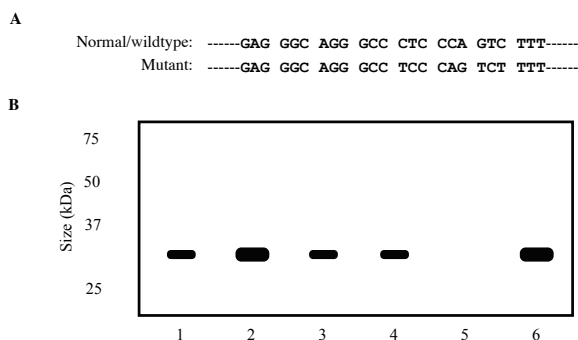

Western blots of serum ficolin-3 from a family without any sick members except for the patient (5). The patient's sisters (1 and 2), mother (3), and father (4), compared to a control with ficolin-3 added (6). (from Munthe-Fog et al. 2014).

Indicate if each of the following statements is true or false.

TRUE FALSE

The mutation is a frame-shift mutation

If a child lacks ficolin-3 protein, at least one of her/his parents should have the same phenotype

All three possible genotypes of the ficolin-3 gene can be determined using Western blots

Sister (1) might be heterozygous

Solution:

1. **True**

Allele (normal) : -----GAG GGC AGG GCC CTC CCA GTC TTT-----
 Allele (mutant): -----GAG GGC AGG GCC TCC CAG TCT TT-----
 C in the normal sequence is deleted and the reading frame shifts to the left.

2. **False**

The lack of ficolin is inherited recessively from both parents. Based on the fact that only no. 5 is a patient and has total absence of ficolin-3.

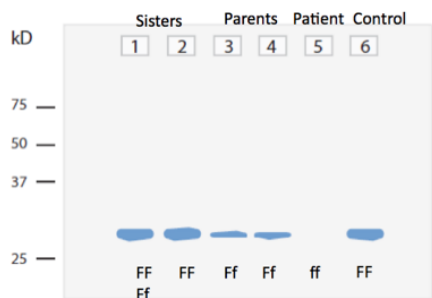

3. **True**

The ficolin-3 serum concentration in heterozygotes (3) and (4) was about half the levels found in persons with wild-type *FCN3*. (2) seems to be homozygous for the wild type, whereas (1) might be heterozygous according to the size of the blot.

4. **True**

This might be true, because the blot of sister (1) is smaller than that of the parents.

DNA from five members of a family, in which dwarf growth occurs (Fig. A), was examined using restriction enzymes, DNA probes, and gel electrophoresis (Fig. B). Dwarf growth occurs due to deficiency of growth hormone.

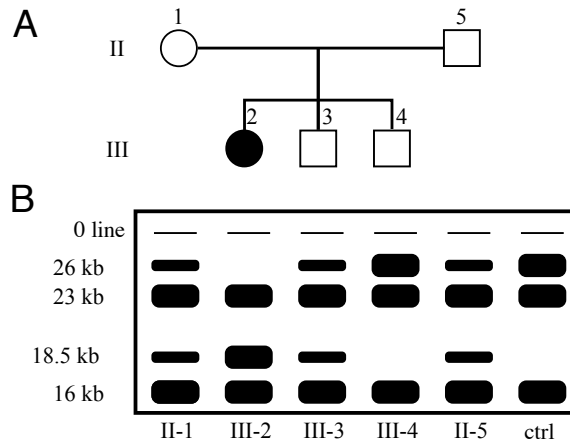

A, pedigree with a dwarf member (2); B, gel electrophoresis plate with size of fragments to the left. DNA from a control person (ctrl) without this type of mutation was also examined (from Phillips et al. 1981).

Indicate if each of the following statements is true or false.

The gene for growth hormone is situated within the 26 kb DNA sequence

	TRUE	FALSE
The gene for growth hormone is situated within the 26 kb DNA sequence	<input type="radio"/>	<input type="radio"/>
The mutation is due to a deletion of the size of 26 kb	<input type="radio"/>	<input type="radio"/>
III-4 will most probably not have children that lack growth hormone	<input type="radio"/>	<input type="radio"/>
The risk that a fourth child of II-1 and II-5 will be a dwarf is 50%	<input type="radio"/>	<input type="radio"/>

The mutation is due to a deletion of the size of 26 kb

III-4 will most probably not have children that lack growth hormone

The risk that a fourth child of II-1 and II-5 will be a dwarf is 50%

Solution:

1. True

The only person that lacks the 26 kb DNA is the dwarf (3).

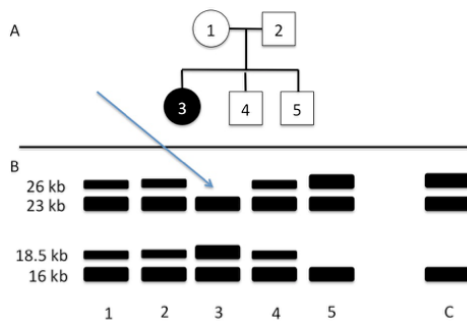

2. False

The 18.5 kb fragment is not found in the control, but present in the dwarf (3), an in a smaller amount in brother (4) and the two parents (1 and 2). Thus the mutation could be a deletion of the size of 26 kb - 18.5 kb = 7.5 kb (that is the conclusion in the reference).

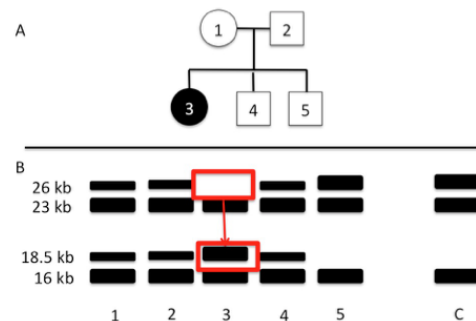

3. True

(5) has DNA similar to the control person. (5) is homozygous with respect to the 26 kb fragment and does consequently not have any

18.5 fragment, and since the mutation is recessive, both parents should carry the mutation in order to get a dwarf growth child.

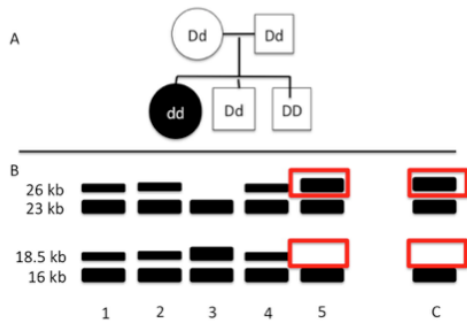

4. **False**

Answer: 25% to get a homozygous recessive (Simple Mendelian inheritance). (1) and (2) are both heterozygotes for the 26 kb piece of DNA.

	D	d
D	DD	Dd
d	Dd	dd

Q. 38

Two human genetic disorders, haemophilia and red-green colour blindness, are both located on chromosome X. The pedigree in the Fig. shows a family with both disorders.

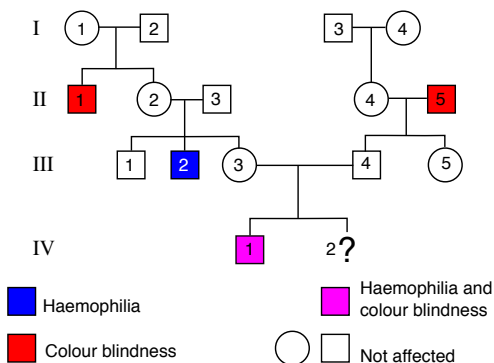

Pedigree of a family suffering from both haemophilia and red-green colour blindness. Blue symbols = haemophilic individuals; red symbols = colour blind individuals; purple symbol (IV-1) = haemophilic+colour blind individuals; white symbols = unaffected individuals. It is assumed that no new mutations related to the two disorders occur in the family.

Indicate if each of the following statements is true or false.

Person II-2 is a carrier of both disorders

At least two individuals in the pedigree carry recombinations due to genetic crossover

If IV-2 (unborn) has Klinefelter's syndrome (XXY) and also has colour blindness, then a non-disjunction must have taken place in the first meiotic division of the mother's egg cell

III-5 marries a man from a population in which the frequency of the allele for colour blindness is 1%. The probability that their firstborn child is a colourblind daughter is 0.25%

Solution:

1. True

Since no new mutations occur, and II-3 does not suffer from any of the two disorders, then II-2 must be a carrier of both disorders because her brother and her son each have one of the two disorders.

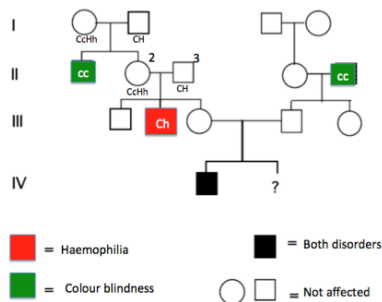

2. True

Persons II-1 and III-2 each suffer from just one of the diseases. They are both male, and therefore they have only one X chromosome. Since their father/grandfather does not suffer from any of the diseases, their mothers must have an X chromosome, that carries the genes for both haemophilia and red-green colour blindness.

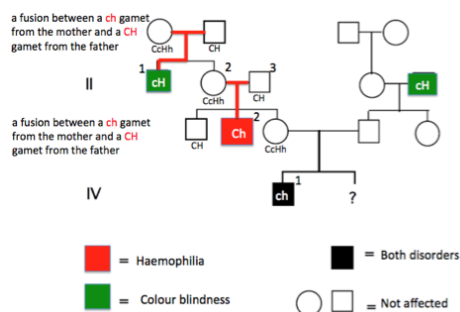

3. False

Person IV-2 must indeed inherit the X chromosomes from the mother, but the non-disjunction must take place in the second meiotic

	TRUE	FALSE
Person II-2 is a carrier of both disorders	<input type="radio"/>	<input type="radio"/>
At least two individuals in the pedigree carry recombinations due to genetic crossover	<input type="radio"/>	<input type="radio"/>
If IV-2 (unborn) has Klinefelter's syndrome (XXY) and also has colour blindness, then a non-disjunction must have taken place in the first meiotic division of the mother's egg cell	<input type="radio"/>	<input type="radio"/>
III-5 marries a man from a population in which the frequency of the allele for colour blindness is 1%. The probability that their firstborn child is a colourblind daughter is 0.25%	<input type="radio"/>	<input type="radio"/>

division in order to get two X-chromosomes each carrying the allele for colour blindness.

Nondisjunction is an erroneous chromosomal segregation that results in an abnormal number of chromosomes (aneuploidy). There are two forms of nondisjunction involving segregation during the cell cycle: failure of a pair of homologous chromosomes to separate in meiosis I, failure of sister chromatids to separate during meiosis II.

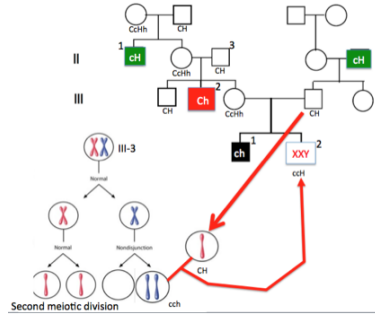

4. True

The probability of having a daughter, who has inherited the mother's gene for colour blindness is 0.5%. The probability of inheriting this gene from the father is 1%. So the probability that she is colour blind is $0.5 \times 0.01 = 0.005$ or 0.5% (note: the mother is heterozygote because she received the allele from her father. The probability that she gives the allele for colour blindness to her daughter is 50%, or 0.5).

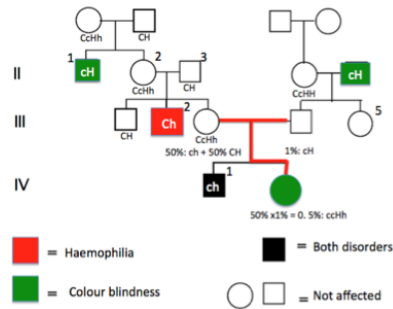

Q. 39

Egg producers prefer hens to roosters, and they select these by using sex-specific traits. Roosters have the sex chromosomes ZZ and hens have ZW (W is a dwarf chromosome perhaps without coding information). In a parental crossing (P) between a black-coloured rooster and a barred (coloured stripes) hen all male chickens became barred and all female chickens black. Breeders knew beforehand that only one gene was involved in the trait.

Indicate if each of the following statements is true or false.

TRUE FALSE

Black plumage dominates over barred

TRUE FALSE

All barred chickens in F2 can be regarded as hens and used for egg production

TRUE FALSE

Half of the male chickens in F2 are heterozygous

TRUE FALSE

All male chickens in F2 are black

TRUE FALSE

Solution:

- False
Barred dominates.

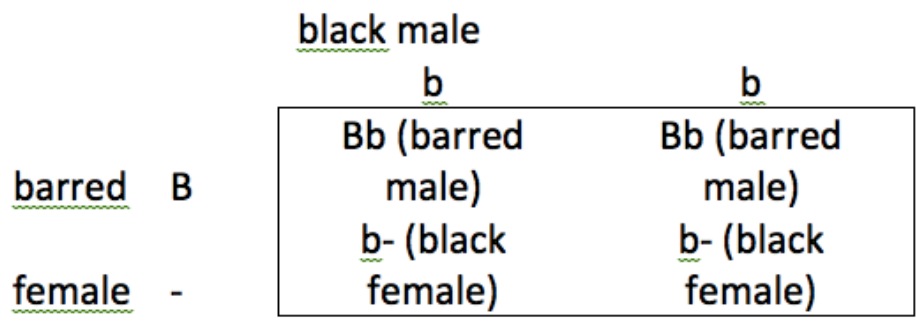

- False
Only half of all female chickens are barred.

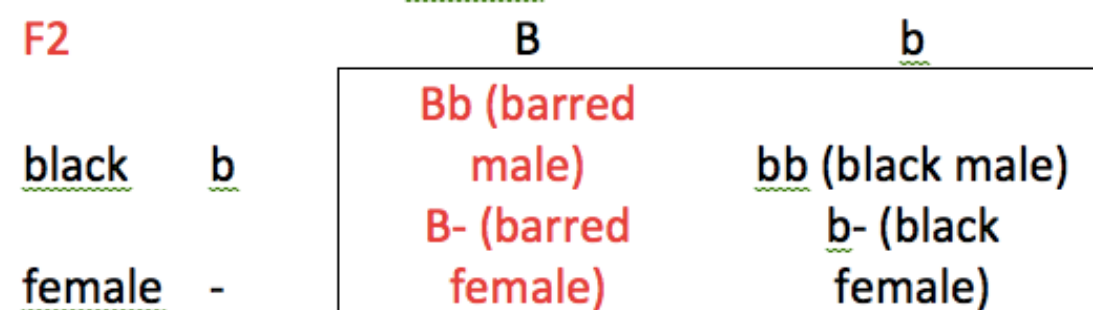

- True
Half is Bb.

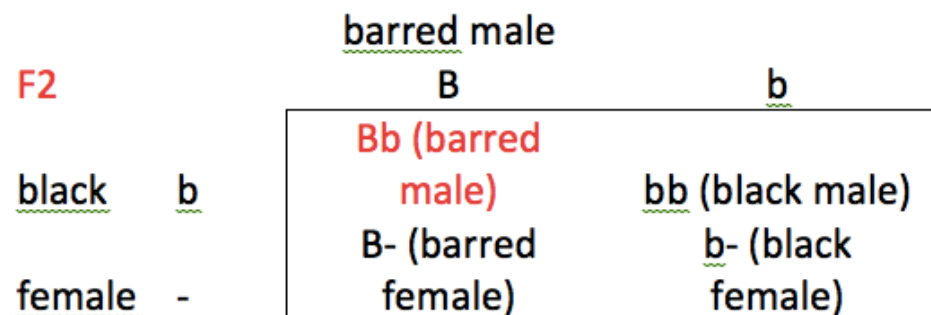

- False
Half is black and half is barred.

		<u>barred male</u>					
		<u>B</u>	<u>b</u>				
F2		<table> <tr> <td><u>Bb</u> (barred male)</td> <td><u>bb</u> (black male)</td> </tr> <tr> <td><u>B-</u> (barred female)</td> <td><u>b-</u> (black female)</td> </tr> </table>		<u>Bb</u> (barred male)	<u>bb</u> (black male)	<u>B-</u> (barred female)	<u>b-</u> (black female)
<u>Bb</u> (barred male)	<u>bb</u> (black male)						
<u>B-</u> (barred female)	<u>b-</u> (black female)						
<u>black</u>	<u>b</u>						
<u>female</u>	-						

Q. 40

The proportion of lactose-tolerance in adults varies globally (Fig.). Lactose tolerance is a 1-locus dominant trait (dominant allele K and recessive allele k).

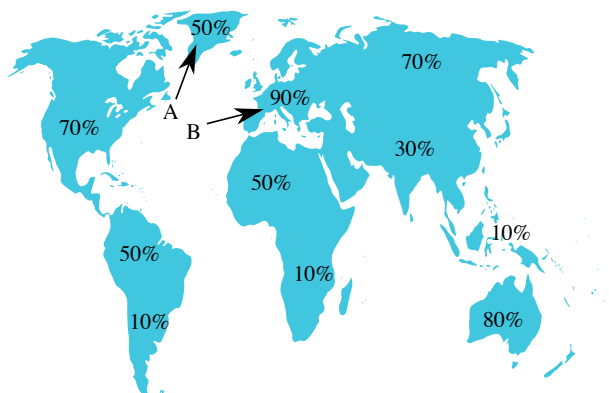

Lactose tolerance (%) among adults around the world. A points to Greenland, B to Europe.

Indicate if each of the following statements is true or false.

	TRUE	FALSE
Assuming that the European (B) population is in Hardy-Weinberg equilibrium, the frequency of K in the next generation will be 0.968	<input type="radio"/>	<input type="radio"/>
Differences in the frequencies of the K allele between populations prove that selection has been acting on this trait	<input type="radio"/>	<input type="radio"/>
In Greenland (A) where the percentage of lactose tolerance is 50%, the frequencies of the alleles k and K are equal	<input type="radio"/>	<input type="radio"/>
Lactose tolerance is assumed to be the ancestral trait among adult humans	<input type="radio"/>	<input type="radio"/>

Solution:

1. **False**

In Europe, lactose tolerance has a frequency of $p[KK + Kk] = 0.900$.
Then lactose intolerance gets the frequency $p[kk] = 1.000 - 0.900 = 0.100$
 $p[k] = \text{square root}(0.100) = 0.316$, and $p[K] = 1.000 - 0.316 = 0.684$.

NB: Although populations in Europe, India, Arabia, and Africa were first thought to have high frequencies of lactase persistence because of a single mutation, lactase persistence has now been traced to a number of mutations that occurred independently.

2. **True**

This is a likely explanation. The frequency of lactose tolerance corresponds with areas in the world, where milk has been part of the ordinary diet due to domestication of e.g. cows. Another selective advantage of milk consumption in Northern Europe is its mitigating effects on reduced sunshine and vitamin D insufficiency. Vitamin D and calcium uptake are related. Without vitamin D, the body may not absorb the calcium it ingests, and instead steals calcium from bones, increasing the risk of osteoporosis and fractures (Knowledge).

3. **False**

In Greenland, lactose tolerance has a frequency of $p[KK + Kk] = 0.50$. Therefore lactose intolerance also has a frequency of $p[kk] = 1.00 - 0.50 = 0.50$. The allele frequency $p[k] = \text{square root}(0.50) = 0.71$, and then the allele frequency $p[K] = 1.00 - 0.71 = 0.29$.

4. **False**

Since animal husbandry is a relative recent innovation in human evolution, we can safely assume that human adults before could not produce lactase (Knowledge).

Q. 41

In mold/mould, synthesis of the amino acid arginine requires prior conversion of a precursor to ornithine, which is then converted to citrulline, which further is converted to arginine. Each of these three steps is catalyzed by a separate enzyme, coded for by a separate gene (Fig.).

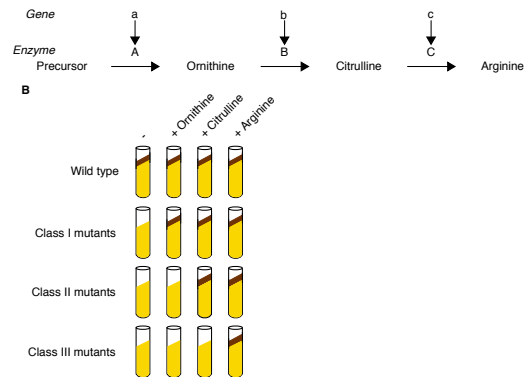

A, biosynthetic pathway for arginine in mold; B, experimental set-up to confirm pathway; dark brown stripe denotes mold growth. The wild type grows on minimal medium, while the mutants only grow with addition of specific nutrients.

Indicate if each of the following statements is true or false.

TRUE FALSE

Class III mutants may have mutations in more than one gene involved in the pathway

 TRUE FALSE

Class I mutants lack activity of all three enzymes

 TRUE FALSE

Mutants, lacking both enzyme A and C, will grow if ornithine and citrulline are both added

 TRUE FALSE

Assuming that an inhibitor to enzyme B is added to the wild type, gene B will be inactivated

 TRUE FALSE

Solution:

1. **True**
2. **False**
3. **False**
4. **False**

Q. 42

This pedigree shows the occurrence of a rare disease phenotype (shown in black) with full penetrance. The genetic disorder is caused by a recessive autosomal allele *d*.

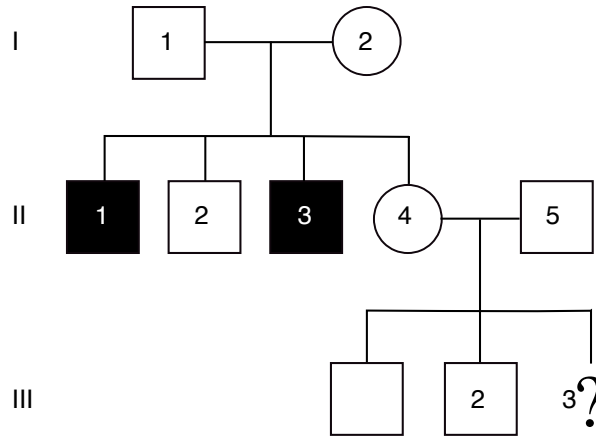

Pedigree of family with an autosomal recessive disease.

Indicate if each of the following statements is true or false.

TRUE FALSE

The probability that II-4 carries the disease allele is 0.50

TRUE FALSE

II-2 and II-4 have the same probability of carrying the disease allele

TRUE FALSE

If assume that II-5 does not carry allele *d*, the probability that III-3 carries this allele is 0.30 or higher

TRUE FALSE

If we assume, that II-5 is heterozygous and III-3 has the disease, then the probability that II-4 is a carrier is 0.5

TRUE FALSE

Solution:

1. **False**

The probability is 2/3 – since II,4 isn't sick, i.e. she cannot be *dd*.

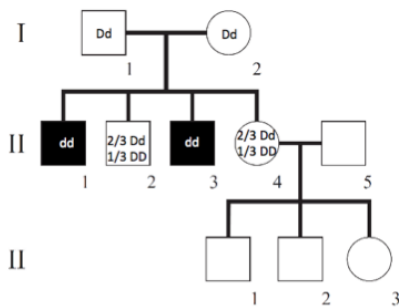

2. **True**

Since the gene is autosomal, there is no difference between sexes, and we cannot know how many of the III,1-3 children are carriers.

3. **True**

The probability that II,4 is a carrier is 2/3, and the probability that one of her children gets the allele is then 1/2. Since the father is dominant homozygous *DD* (see figure legend), the probability becomes $2/3 * 1/2 = 1/3$.

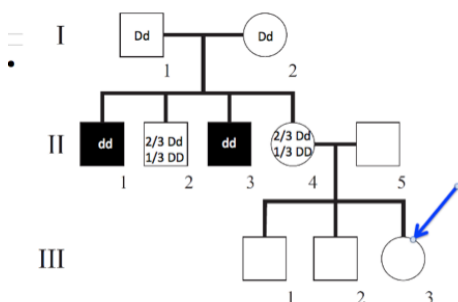

4. **False**

III-3 is sick and thus dd , then one d has to come from II-4, and the probability becomes 1.0 that II-4 is a carrier.

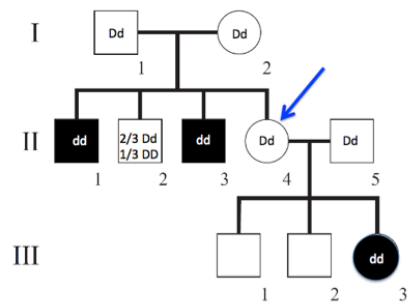

Eelgrass (*Zostera marina*) is a key species in Danish coastal waters, which during summer rarely get warmer than 18°C. In an experiment, the growth rate of eelgrass was measured at three temperatures and under the influence of the invasive red alga *Gracilaria vemiculophylla* (Fig.). A hypothesis is that global warming and the presence of *Gracilaria* negatively affect eelgrass.

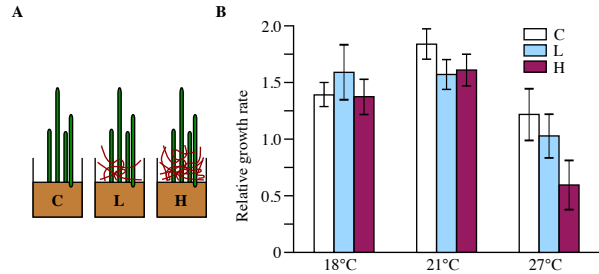

A, three buckets with eelgrass were exposed to increasing amounts of *Gracilaria*. C = no *Gracilaria*; L = Low *Gracilaria* content; H = High *Gracilaria* content per bucket; Fig. B, relative growth rate of eelgrass at three temperatures and together with increasing amounts of *Gracilaria* (white bar = C; light blue bar = L; purple bar = H in Fig. A) (from Höffle et al. 2011). **If error bars do not overlap, the differences are statistically significant.**

Indicate if each of the following statements is true or false.

TRUE FALSE

Irrespective of temperature, *Gracilaria* inhibits the growth rate of eelgrass

TRUE FALSE

In general, temperature affects the growth rate of eelgrass

TRUE FALSE

There is a combined effect of *Gracilaria* and temperature on the growth of eelgrass

TRUE FALSE

In Danish waters without *Gracilaria*, eelgrass growth is temperature limited

TRUE FALSE

Solution:

1. **False**

Gracilaria depresses the growth of eelgrass at 21 and 27°, but not at 18°C. Thus the response is not general.

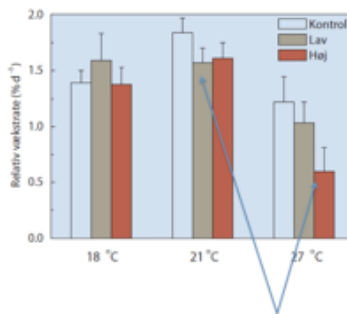

2. **True**

Seen from figure. The results show that eelgrass growth rate peaks at 21°C.

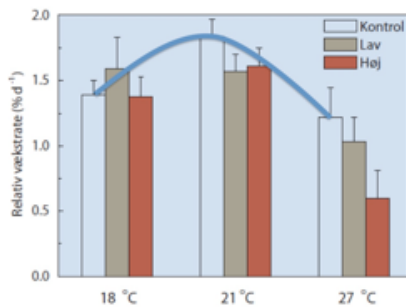

3. **True**

Plots of growth of C, L and H against temperature. The difference in bar height between the three bars at each temperature varies. This suggests an interaction between the two predictor variables (*Gracilaria* and temperature).

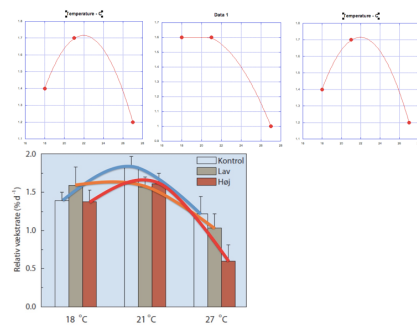

4. True

Eelgrass has the highest growth rate at 21°C, and this is above the normal sea temperature (18°C) during summer in Denmark (intro text & Figure). Higher temperature certainly inhibits growth.

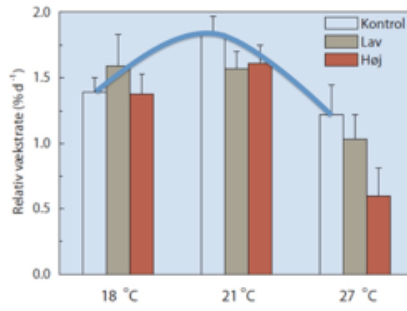

Arctic tundras are warming faster than the global average. This influences their soil carbon reservoirs. The permafrost layer in the tundra is covered by an active layer, which has an annual thaw/refreeze dynamic. The influence of tundra vegetation as a driver of this dynamics was studied in Siberia from 2006 to 2012. Four parameters were measured in plots, where the woody vegetation was removed (blue bars in the figure), and in undisturbed control plots (black bars).

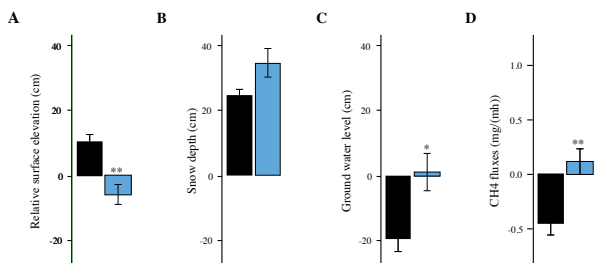

A, Surface elevation relative to ground surface level (0); B, spring snow depth; C, summer ground water level compared to soil surface level; D, August CH4 emission (+ value, emission). *, significant differences (from Nauta et al. 2014).

Indicate if each of the following statements is true or false.

TRUE FALSE

Soil subsides when its woody vegetation is removed

TRUE FALSE

Undisturbed tundra woody vegetation functions as a source of global methane emission

TRUE FALSE

Removal of woody vegetation initiates a cycle, leading to more dominance of water-tolerant plants

TRUE FALSE

After removal of woody vegetation, the chain of events will be: Fig. B --> Fig. C --> Fig. A --> Fig. D

TRUE FALSE

Solution:

1. True

This can be seen from Fig. A. When vegetation is removed, the soil layer gets warmer, leading to more thawing and melting of ice pockets inside the active layer. The result is that this layer partially collapses.

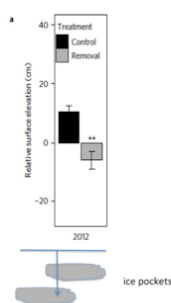

2. False

Natural tundra is a sink of atmospheric methane (Fig. D).

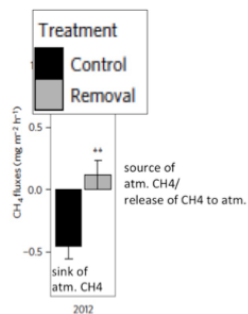

3. True

In Fig. C, we see that ground water level increases when vegetation is removed. This change favours more water-tolerant plants.

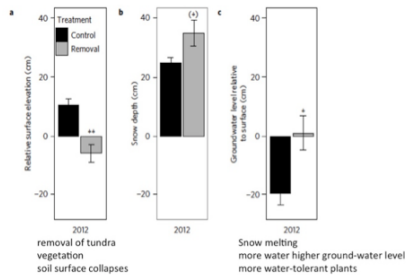

4. False

In the paper (Nauta et al. 2014), the suggested order is: Fig. A --> Fig. B --> Fig. C --> Fig. D. When woody vegetation is removed, the active layer warms up, ice clumps embedded in the active layer thaw, the soil collapses (Fig. A: low surface elevation), the low areas catch snow (Fig. B: snow depth), this increases spring water level (Fig. C: groundwater level), and makes conditions more anaerobic, resulting in release of methane in the decomposition of organic matter (Fig. D: CH₄ efflux).

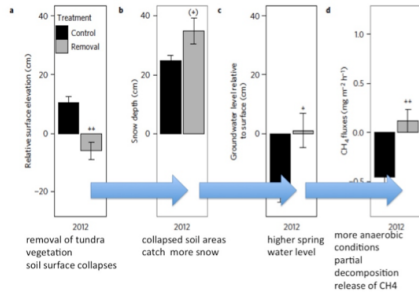

Q. 45

The structure of flowers has many morphological characters important to reproductive success, e.g. sexual dimorphism (dioecy, monoecy). Such characters show phylogenetical conservatism, and thus may be used in evolutionary analysis.

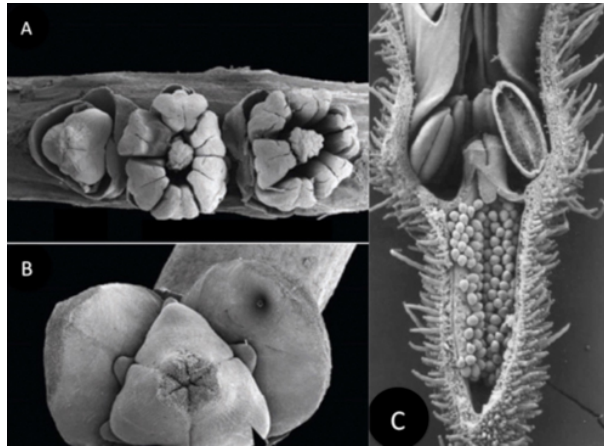

A-B, flowers of a palm; C, longitudinal section of a flower of species saxifrage (from Soltis et al. 2003, Castaño et al. 2014).

Indicate if each of the following statements is true or false.

TRUE FALSE

The palm in Fig. A is monoecious (i.e. hermaphroditic plants with unisexual flowers)

TRUE FALSE

The palm in Fig. A originates from an ancestor, which most likely had hermaphroditic flowers

TRUE FALSE

The palm and the saxifrage are both most likely dicots

TRUE FALSE

If structures through evolution become more specialized, one would expect the saxifrage to be phylogenetically older than the palm

TRUE FALSE

Solution:

1. True

Fig. A shows three flowers: a female and two males and they are on the same branch (Fig. A), i.e. the species is monoecious.

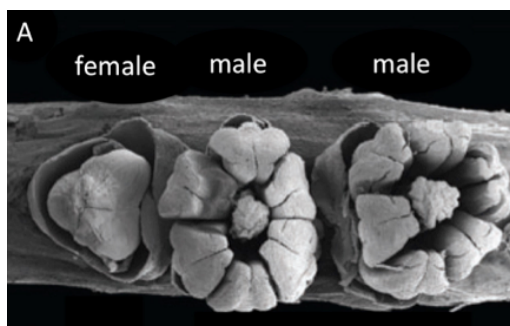

2. True

Fig. A shows vestiges of a gynoecium in the center of the male flower, and in Fig. B it is possible to see small staminodia outside and beneath the carpels.

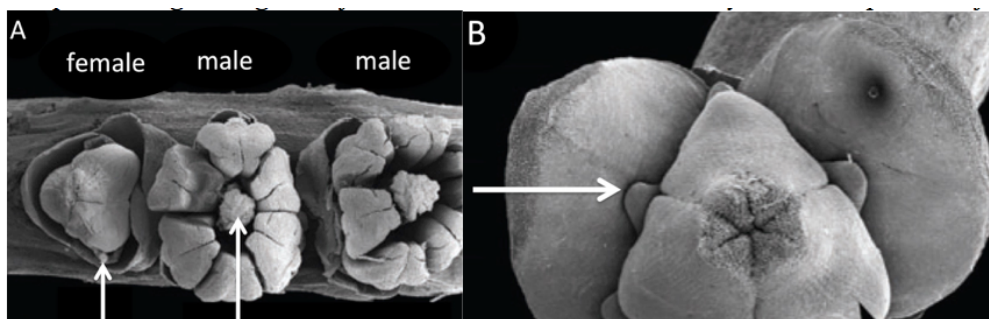

3. False

The palm is 3-meric (6 stamens, 3 carpels, 3 petals) and thus most like a monocot, and the saxifrage is most likely 5-meric (three and a half anthers can be seen, at least there are more than 3). Thus it is most likely a dicot (Knowledge).

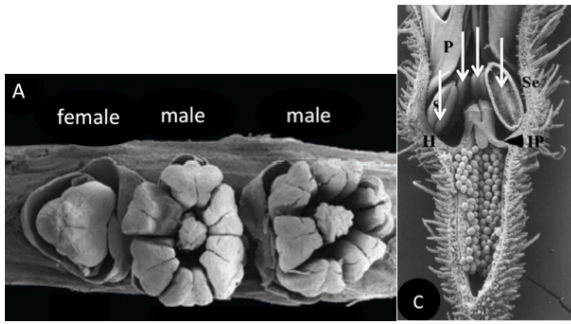

4. **False**

The palm is open and with easy access, whereas the saxifrage has a very narrow corolla and thus is probably more recent.

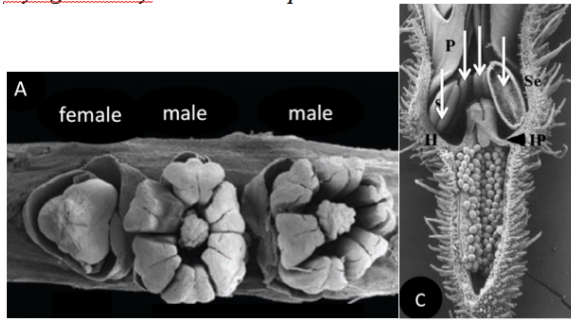

Q. 46

Many plants reproduce both sexually and vegetatively (clonally). A hypothesis says: As both reproductive modes require energy, a negative trade-off is expected to exist between the two reproductive modes. This was studied in a population of Japanese bamboo (*Sasa veitchii*) (Figs A-B).

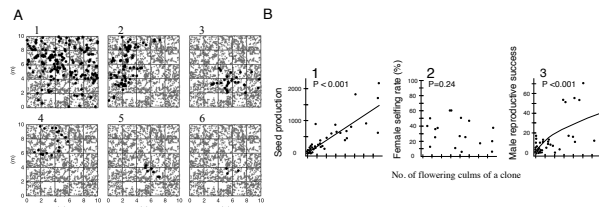

A, six plots (10 x 10 m) each presenting the spatial distribution of a bamboo clone; black dots show the positions of all flowering culms of the clone, whereas all the grey dots show the positions of all flowering culms of all the other clones in the plot; B, relationships between no. of flowering culms of a clone and its sexual success (measured in three ways). A regression line is present, if the relationship is significant (from Matsuo et al. 2014).

Indicate if each of the following statements is true or false.

TRUE FALSE

More "investment" in clonal growth negatively affects male reproductive success of an individual bamboo

 TRUE FALSE

More "investment" in clonal growth negatively affects female reproductive success of an individual bamboo

 TRUE FALSE

Larger bamboo clones have more self-pollination

 TRUE FALSE

The gain in female fitness per produced flowering culm diminishes with increasing clone size

 TRUE FALSE

Solution:

1. **False**

Male siring, i.e. pollen transport to stigma, increases log-linearly with clone size (Fig B, male siring).

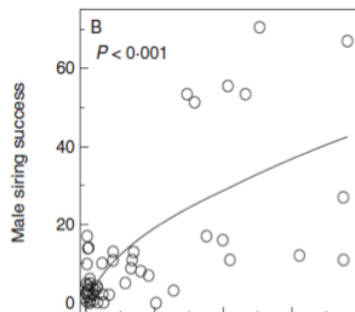

2. **False**

Female reproductive success, i.e. seed production, increases linearly with clone size (Fig B, seed production).

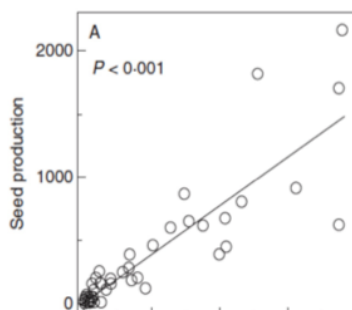

3. **False**

There is no significant relationship (no regression lines). This is counterintuitive, one would expect selfing to increase with clone size. The reason why one does not see any significant relationship could be due to the strong intermingling of culms from different clones in the study plot (seen in Fig. A black dots and grey dots are intermingled).

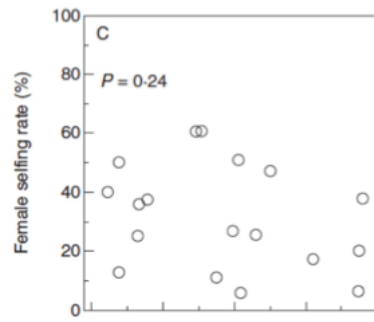

4. False

The return per unit growth of clone is constant because the line is straight (Fig. B, seed production). For the male function, on the other hand, there is a diminishing return with each invested unit of energy in clonal growth.

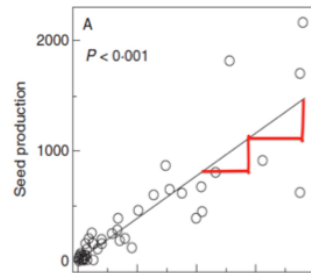

Q. 47

The carnivorous plant sundew, *Drosera capensis*, has tentacles with mucilage on their leaf surface. In an experiment, plants were each fed 50 fruit flies per day for ten weeks (Table). The weight of each fruit fly was measured before and after digestion, showing an average dry weight loss of 60%. Estimates of different parameters are given in table. Enzyme activity in mucilage was estimated 24 h after either being fed with fruit flies or exposed to mechanical irritation (the addition of polystyrene balls, which were the size of fruit flies).

Activities of AP and PD, PA and nutrient levels in leaf tissue.

	Enzyme activity in mucilage	Enzyme activity in mucilage	Enzyme activity in mucilage	Ratio of nutrients in leaf tissue	Ratio of nutrients in leaf tissue	Ratio of nutrients in leaf tissue
	Acid phosphatase (AP), millimol/(mg protein x hour)	Phospho-diesterase (PD), micromol/(mg protein x hour)	Total proteolytic activity (PA), unit/mg protein	N:P	N:K	K:P
Mechanical irritation	65.4	4.07	297			
Control = unfed plants	24.7	2.04	363	47.6	1.2	38.8
Fruit fly-fed plants	297	11.6	2000	30.1	2.8	10.7

Indicate if each of the following statements is true or false.

TRUE FALSE

Results indicate that growth of *D. capensis* plants is normally limited by N

 TRUE FALSE

Mechanical irritation increases enzyme activity, but proteolytic activity requires the presence of insects

 TRUE FALSE

No chitinase activity was observed in the mucilage, which might explain the fact that the weight of the fruit flies was only reduced by 60%

 TRUE FALSE

N was a more efficiently absorbed nutrient from fruit flies than K

 TRUE FALSE

Solution:

1. **False**

The drop in the ratio N:P shows that adding flies results in more consumption of N compared to P, i.e. P must have been limiting. From 47.6 to 30.1.

The increase in the ratio N:K shows that adding flies results in more consumption of K compared to N, i.e. K is limiting.

The drop in the ratio K:P shows that adding flies results in more consumption of P compared to K, i.e. P is limiting.

	N:P	N:K	K:P
Control = unfed plants	47.6	1.2	38.8
Fruit fly-fed plants	30.1	2.8	10.7

2. **True**

Both AP and PD increased with mechanical irritation, whereas PA decreased slightly.

	<u>Acid phosphatase (AP), millimol/(mg protein x hour)</u>	<u>Phosphodiesterase (PD), micromol/(mg protein x hour)</u>	<u>Total proteolytic activity (PA), unit/mg protein</u>
<u>Mechanical irritation</u>	65.4	4.07	297
<u>Control = unfed plants</u>	24.7	2.04	363
<u>Fruit fly-fed plants</u>	297	11.6	2000

3. **True**
The exoskeletons (chitin) of the fruit flies were not digested.
4. **True**
The increase in the ratio N:K shows that adding flies results in more uptake and consumption of K compared to N ("more free, unused N is left in the plant").

 | Q. 48

Plants have different photosynthetic systems. Most plants have the C₃ system, but others, especially grasses, have a C₄ system. The two systems show different photosynthetic rate, when CO₂ and ambient temperature vary (Fig.).

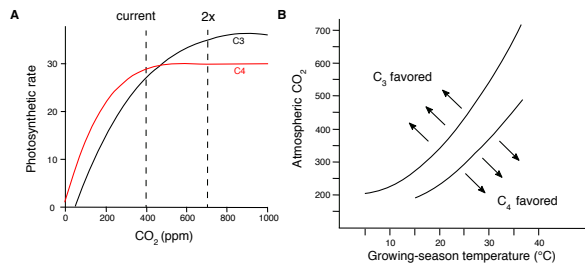

Photosynthetic rate (A) and expected dominance (B) of C₃ and C₄ plants as a function of ambient CO₂ level and temperature (from Ehleringer et al. 1997).

Indicate if each of the following statements is true or false.

TRUE FALSE

The proportion of C₄-plant species increases towards the poles

 TRUE FALSE

At current atmospheric CO₂ levels, CO₂ is limiting the growth of both C₃- and C₄-plants

 TRUE FALSE

The predicted CO₂-increase can be more advantageous to C₄- than C₃-plants

 TRUE FALSE

In dry and warm regions during the last glacial period, C₄-plants were probably more widespread

 TRUE FALSE

Solution:

1. **False**
2. **False**
3. **False**
4. **True**

Primrose has heterostyly, i.e. two flower forms on different individuals: P-plants with long style and short stamens inside the corolla tube, and T-plants with short style and stamens higher in the corolla (Fig. A). Darwin crossed T x P primroses (Table), and found that heterostyly increases outcrossing and thus fruit set. A bee inserts its tongue in a P-flower and gets pollen on the tip of its tongue, and then places the pollen on the stigma of a T-plant and *vice versa* for T-pollen to P-stigma (Fig. B). Heterostyly is controlled by one gene (T is *Ss* and P is *ss*; *SS* is non-viable, *S* is dominant to *s*).

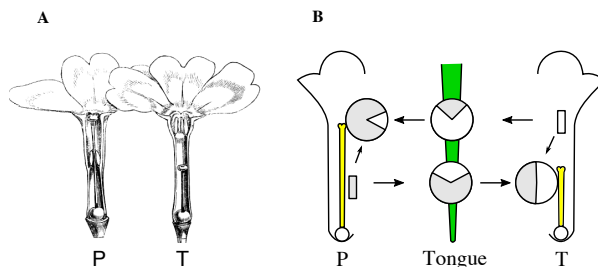

A, flower forms P (left) and T (right) of primrose; B, flowers P and T, with a bee's tongue (green) in between; arrows show amount of pollen transferred along different routes from the anther, to tongue and to the stigma (white and grey slices are T- and P-pollen, respectively).

Fruit set (Number of fruits) after 100 T x T and P x P crossings and 100 T x P and P x T crossings.

	Number of fertilized flowers	Number of fruits
T x T and P x P	100	63
T x P and P x T	100	75

Indicate if each of the following statements is true or false.

- | | TRUE | FALSE |
|--|-----------------------|-----------------------|
| Frequencies of T and P in a primrose population stay the same, if mating is random with respect to form, and all crossings give the same fruit set | <input type="radio"/> | <input type="radio"/> |
| Incomplete sterility within the same flower form is seen in the population as a deviation from a 1: 1 T: P ratio | <input type="radio"/> | <input type="radio"/> |
| The two routes of pollen transfer (T --> P or P --> T) are equally efficient in terms of the pollen transferred | <input type="radio"/> | <input type="radio"/> |
| Pollen deposition from tongue to stigma is more difficult than pollen harvesting from anther to tongue | <input type="radio"/> | <input type="radio"/> |

Solution:

1. **False**

T x T --> produces 2/3 T (excluding *SS*-abortions) and 1/3 P;

P x P --> only P;

T x P --> 1/2 T and 1/2 P.

Thus P will slowly dominate completely (even if as shown in the table that T x T and P x P crossings are slightly less fecund (75% vs. 63%)).

2. **True**

If sterility is complete, the T: P ratio becomes 1: 1. Any successful T x T and P x P crossings will skew the ratio (Statement 1)

3. **False**

The transfer from P to T is more efficient, that is more pollen is transferred (the dark-coloured slice on the stigma of the T plant = 48.5%, i.e. 48.5% of the pollen from the P-anther reach the T stigma) than the route from T to P (the white slice on the stigma of the P plant = 12.5%, i.e. 12.5% of the pollen from the T-anther reach the P stigma) (Fig. B).

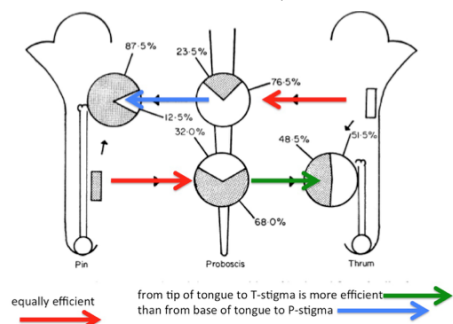

4. **True**

The percentages of pollen transferred to tongue from anther and from tongue to stigma change differ. Thus the movement of the tongue messes up the transfer.

END